

4M-E 6 CYLINDER

ENGINE CODING

ENGINE IDENTIFICATION

Engine number is stamped on a machined pad on the right side of engine block. Engine code is also printed on a sticker attached to cylinder head cover.

| Engine Identification | |
|----------------------------------|------|
| Application | Code |
| Cressida & Supra (2563 cc) | 4M-E |

ENGINE, CYLINDER HEAD & MANIFOLDS

ENGINE

Removal – 1) Disconnect battery and drain cooling system. Remove hood and fan shroud. Remove radiator hoses, radiator, heater hoses and all oil cooler hoses. Remove oil pressure sending wire and alternator wiring.

2) Remove air cleaner and air intake ducting. Disconnect brake booster vacuum hose. Disconnect distributor primary wiring and coil secondary wiring. Label and disconnect all fuel lines, vacuum hoses and electrical wiring running between engine and engine compartment.

3) Disconnect starter wiring and accelerator connecting rod. If equipped with manual transmission, disconnect clutch flexible hose from master cylinder tube and cap hose end to prevent fluid leakage. On all models, disconnect power steering feed hose.

4) Raise front and rear of vehicle with jack and support on stands. Disconnect exhaust pipe from manifold and remove exhaust pipe supports and insulator. Disconnect speedometer drive cable and back-up light wiring.

5) On manual transmission models, remove console box and gear shift lever. On automatic transmission models, remove connecting rod swivel nut and disconnect control rod from shift lever.

6) On all models, remove propeller shaft and plug rear of transmission to prevent oil leakage. Take off rear engine undercover and remove front engine mounts. Support transmission with jack and remove rear engine mount and crossmember.

7) Lower jack supporting transmission and remove stands. Using an engine hoist, remove engine and transmission assembly from vehicle.

Installation – To install, reverse removal procedure and note the following: Check all fluid levels and linkage adjustments prior to starting engine.

INTAKE MANIFOLD

Removal – 1) Disconnect battery and drain coolant. Remove air cleaner and distributor cap. Remove radiator inlet

hose and heater hoses. Disconnect temperature gauge sending wire and fuel line.

2) It is necessary to remove air intake chamber with throttle body prior to intake manifold removal. Mark all vacuum, coolant and fuel hoses for identification and disconnect from air chamber. Disconnect intake connector, cold start injector, throttle link and throttle wire for automatic transmission. Remove mounting bolts and lift air chamber off of manifold.

3) Disconnect fuel injection wiring connectors and remove wiring clamps. Remove 4 bolts and pull out fuel delivery pipe with injectors. Remove pressure regulator at center of manifold, EGR valve, and disconnect remaining hoses. Remove mounting bolts and lift off manifold.

CAUTION – When disconnecting delivery pipe and injectors, use container to catch the large amount of gasoline which will be expelled.

Installation – Thoroughly clean all gasket surfaces and install new gaskets. Install manifold assembly and gradually tighten bolts working from center out. Install remaining components in reverse of removal procedure.

NOTE – When installing injectors, lubricate "O" rings and insulators with gasoline.

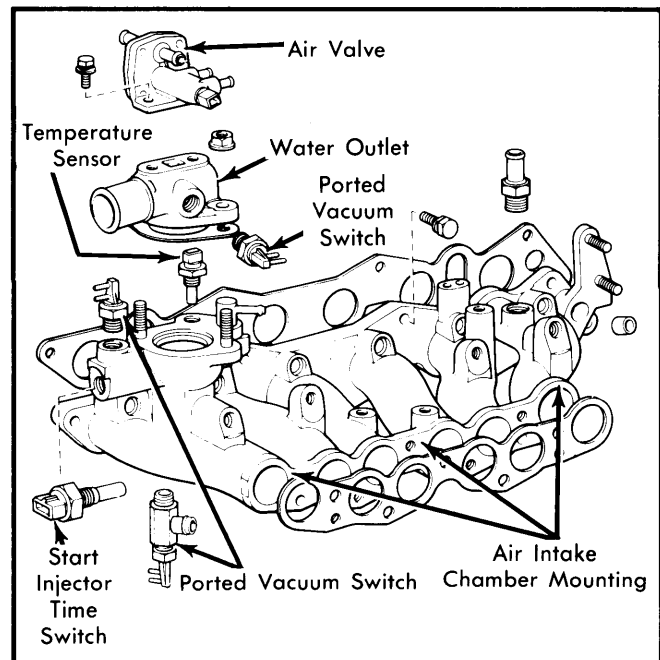

Fig. 1 Toyota 4M-E Intake Manifold Assembly

CYLINDER HEAD & ROCKER ARMS

Removal – 1) Remove intake and exhaust manifolds. Remove heater and by-pass hoses attached to head. Remove spark plugs and cylinder head cover. Turn crankshaft so that number 1 piston is at TDC on firing stroke and note that mating marks are aligned on timing gear and timing chain.

4M-E 6 CYLINDER (Cont.)

2) Remove chain tensioner, then remove timing gear bolt noting that bolt has *LEFT* hand threads. Loosen head/rocker shaft bolts a little at a time in reverse of tightening sequence illustrated. Lift off rocker arm assembly, then lift head straight up from block.

Installation — Clean all gasket surfaces and apply sealer to cylinder head, around oil holes in the block, and in area of timing chain cover and block. Install new gasket. Clean all foreign matter from bolt holes and place cylinder head on block. Make sure valve adjusting screws have been loosened and install rocker shaft assembly. Install bolts and tighten in several steps according to the sequence illustrated. Align timing marks and reverse removal procedure to complete assembly.

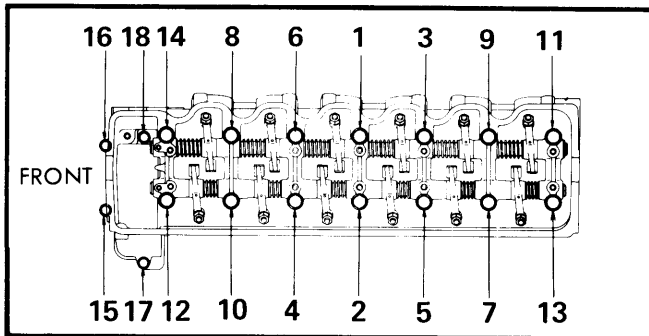

Fig. 2 Cylinder Head/Rocker Arm Bolt Tightening Sequence (Loosen in Reverse Order)

CAMSHAFT

CAMSHAFT

Removal — Remove rocker arm assembly. See *Cylinder Head*. Remove camshaft sprocket bolt (*LEFT* hand threads) and separate sprocket from camshaft. Remove camshaft bearing caps and keep in order for assembly. Remove camshaft from head and check for maximum runout of .0012" (.03 mm).

Installation — Lubricate camshaft bearing journals and place camshaft in position. Assemble bearing caps in original positions with arrow marks toward front. Complete assembly in reverse of removal procedure.

CAMSHAFT BEARINGS

Inspect bearings for wear or damage. Check that oil clearance does not exceed .004" (.10 mm). When checking clearance, use Plastigage method. Bearings are available in standard, .002", .010" and .020" (.05, .25 and .50 mm) over-sizes.

CAMSHAFT END THRUST

Install camshaft in cylinder head and tighten all bearing caps. Attach dial indicator and check end thrust at flange end. Maximum clearance is .012" (.3 mm). Specified standard clearance is .003-.007" (.08-.18 mm).

CAM HEIGHT

Measure cam height. Minimum for intake is 1.696" (43.08 mm). Minimum for exhaust is 1.699" (43.15 mm). If height is less than specified, replace camshaft.

ENGINE FRONT COVER

Remove crankshaft damper attaching bolt and remove damper using suitable puller (09213-41013). Remove oil pan and remove front cover bolts and front cover. Use liquid sealer on front cover gaskets when assembling.

ENGINE FRONT COVER OIL SEAL

Inspect oil seal lip and replace if worn or damaged. Pry old seal out without damaging cover or retainer. Install seal using replacer tool (09223-50010). Apply multipurpose lubricant to seal lip.

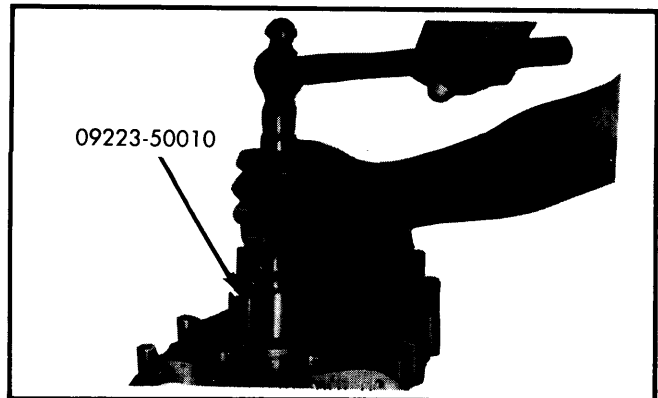

Fig. 3 Using Special Seal Installing Tool to Drive in Front Oil Seal

TIMING CHAIN

Removal — See *Valve Timing*. Remove cylinder head cover, rocker arm shafts and camshaft. Remove cylinder head. Remove crankshaft damper attaching bolt and remove damper using suitable puller (09213-41013). Remove oil pan, timing chain cover and timing chain.

Installation — 1) Inspect chain, sprockets and tensioner. Position crankshaft sprocket so that key is pointed straight toward cylinder head and Toyota mark is in line with pump sprocket shaft. Install timing chain with white links aligned with punch marks on crankshaft gear and pump gear. See Fig. 5.

NOTE — Do *NOT* confuse index marks. Plated or white links align with punch marks on gears. Toyota symbol marks align with each other.

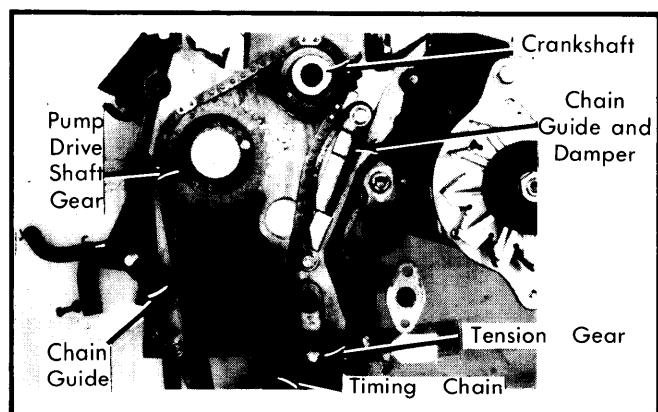

Fig. 4 Front View of Timing Chain and Gears

4M-E 6 CYLINDER (Cont.)

2) Insert bolt in collar and install both chain vibration dampers and guide. With head and camshaft in position, assure that camshaft flange pin is aligned with embossed mark on rocker support number 1. Align mating link on chain with punch mark on camshaft drive gear and install drive gear on camshaft. Note that attaching bolt has LEFT hand threads.

3) Adjust timing chain tension by first rotating engine in normal direction (clockwise) until chain is at most slack position. Loosen tensioner locknut, then turn adjusting screw clockwise until resistance is felt. Loosen screw 2 full turns and tighten lock nut. If chain is noisy after starting engine, loosen adjusting screw 1/2 turn more. See *Valve Timing*.

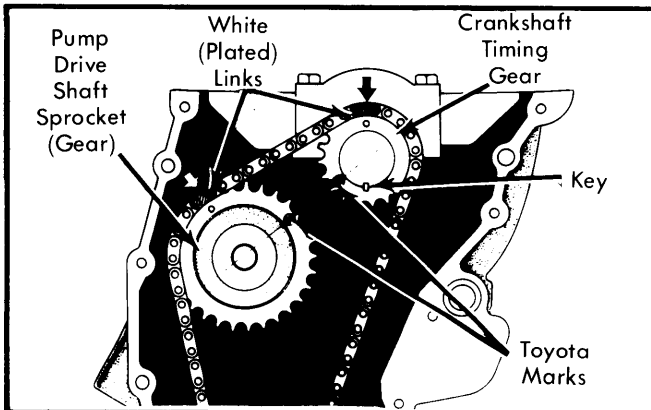

Fig. 5 Timing Chain with Pump Sprocket and Crankshaft Marks Aligned

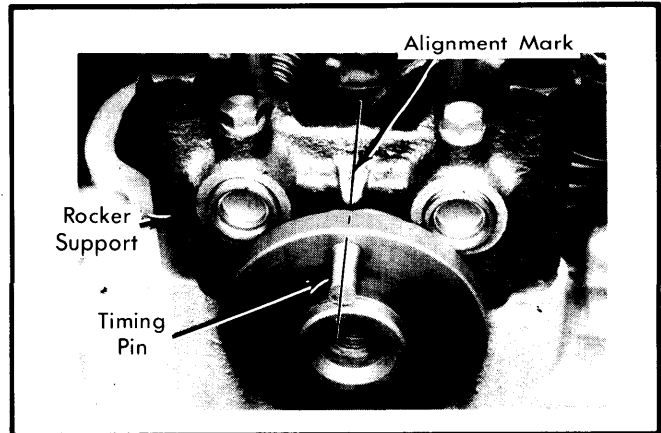

Fig. 6 Camshaft Flange Straight Pin Aligned with Support For Installation of Camshaft Gear

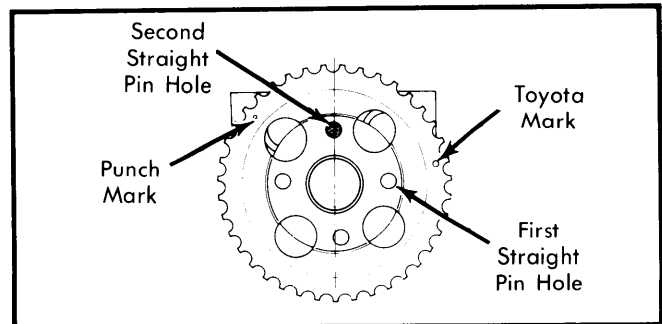

Fig. 7 Front View of Camshaft Gear with Alignment Marks and Straight Pin Holes

OIL PUMP SHAFT

1) With front cover and timing chain removed, use puller (09213-36010) to remove pump shaft sprocket. Remove thrust plate bolt and pull pump shaft from cylinder block. Replace and tighten sprocket on shaft, then check end play between gear and plate with feeler gauge. If beyond limits, replace thrust plate.

2) Check bearing bore diameter with inside micrometer and journal diameter with outside micrometer. Standard clearance is .0010-.0026" (.025-.066 mm). If clearance exceeds .0031" (.08 mm), replace bearings with special tool (09233-41010).

Oil Pump Shaft Specifications

| Application | In. (mm) |
|----------------------------|-------------------------|
| Out-of-Round & Taper Limit | .0004 (.01) |
| Thrust Clearance | |
| Standard | .002-.005 (.05-.13) |
| Wear Limit | .012 (.30) |
| Bearing Clearance | |
| Standard | .0010-.0026 (.025-.066) |
| Wear Limit | .003 (.08) |

VALVE TIMING

1) Rotate crankshaft in normal direction (clockwise) so that number 1 piston is at TDC on compression stroke. Check that camshaft flange timing pin is aligned with embossed mark on rocker support. (Timing chain cover graduation should indicate 0° mark aligned with notch in pulley.)

VALVES

VALVE ARRANGEMENT

Left Side — All Intake.

Right Side — All Exhaust.

VALVE GUIDE SERVICING

1) Break off valve guide bushing at snap ring and remove snap ring. Heat cylinder head to approximately 176-212°F (80-100°C) and drive out bushing toward combustion chamber.

2) Allow head to cool and measure cylinder head bushing bore. If bore exceeds .5125" (13.018 mm), machine bore to .514" (13.054 mm) and insert .002" (.05 mm) oversize bushing. Head should be heated to 176-212°F (80-100°C) and bushing driven in with drift (09201-60011) until snap ring contacts head.

4M-E 6 CYLINDER (Cont.)

3) Measure installed height of .650" (16.5 mm) for intake guide and .551 (14 mm) for exhaust guide. Hand ream guide bore to provide specified stem clearance.

NOTE — Valve guide replacement is recommended whenever new valves are installed.

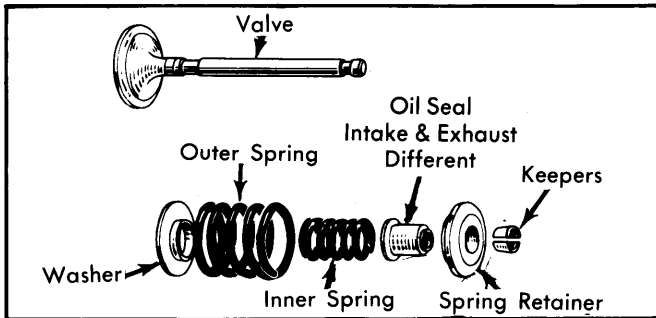

Fig. 8 Disassembled View of Valve Components

VALVE STEM OIL SEALS

Intake seals are slightly longer than exhaust valve seals and must not be switched. To install, assemble in order: plate washer, oil seal, inner and outer springs, and valve spring retainer. With suitable tool (09202-43011), install retainer locks.

VALVE & VALVE SPRING

Mark each valve and using valve spring compressor, remove valves, valve retainers, retainer locks, springs and valve stem oil seals. When replacing valve springs, closed coil ends face toward cylinder head.

VALVE SPRING HEIGHT

Measure valve spring free length with caliper type ruler and check for squareness within .063" (1.6 mm). Using a spring tester, check load when spring is compressed to installed height. Check installed height with valve in closed position by measuring distance from upper edge of washer to lower edge of spring retainer.

ROCKER ARM ASSEMBLY

Check arm-to-shaft clearance by twisting on shaft. Little or no movement should be felt. If movement is felt, disassemble and inspect. Bushings may be replaced and finished to give standard clearance of .0005-.0013" (.012-.033 mm) using pin hole grinder. Assemble rocker arm assembly, starting with rocker support number 1. Install on head and tighten bolts in sequence shown in Fig. 2.

NOTE — Disassemble and mark all parts for reassembly in proper order. Loosen adjusting screws and nuts prior to installing rocker arm assembly.

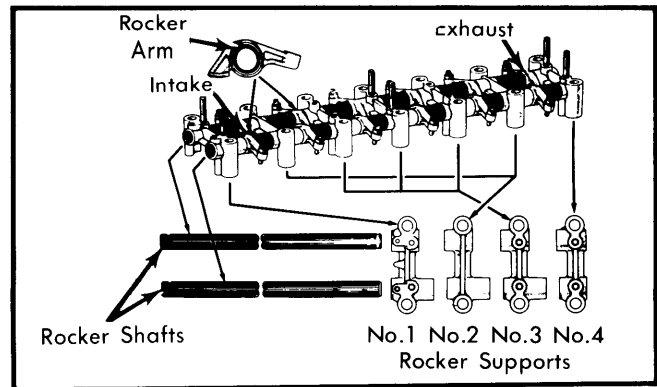

Fig. 9 Assemble Rocker Arm Assembly as Shown (Start with Rocker Support No. 1)

VALVE CLEARANCE ADJUSTMENT

1) With No. 1 piston at TDC of compression stroke, adjust intake valves 1, 2, and 4, and exhaust valves 1, 3, and 5 to specified clearance.

2) Rotate crankshaft one turn (360°) clockwise and adjust intake valves 3,5 and 6, and exhaust valves 2,4 and 6.

Valve Clearance Specifications

| Valve | Hot In. (mm) | Cold In. (mm) |
|---------|-----------------|------------------|
| Intake | .011 (.28) | .010 (.25) |
| Exhaust | .014 (.35) | .013 (.33) |

PISTONS, PINS & RINGS

PISTON & ROD ASSEMBLY

Removal — With cylinder head and oil pan removed, remove connecting rod caps and remove bearings. Push piston and rod assembly up through cylinder head side. Mark all components with cylinder numbers for correct reassembly.

Installation — 1) Apply oil to piston and piston rings. Install rings with mark on side of ring facing upwards. Position piston ring gaps as shown in illustration. Using suitable ring compressor, install piston and rod assembly in cylinder block. Make sure mark on piston faces front.

2) Replace connecting rod caps with mating marks aligned. Tighten nuts evenly in 2 or 3 steps and check connecting rod side play.

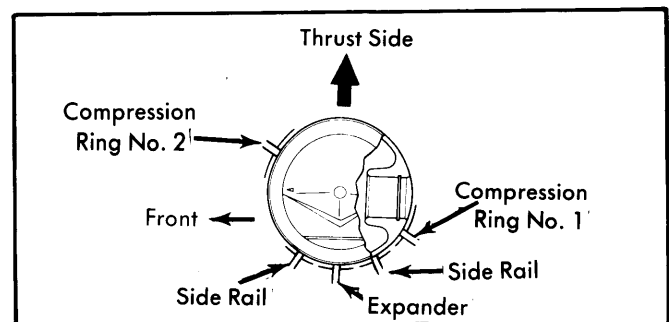

Fig. 10 Position Ring Gaps as Shown for Installation

4M-E 6 CYLINDER (Cont.)

FITTING PISTONS

Measure top, center and bottom of cylinder bore with dial indicator. If wear exceeds .008" (.2 mm) or taper and out-of-round exceeds .0008" (.02 mm), cylinders must be rebored. Bore in sequence number 1, 3, 6, 4, 2 and 5 cylinders. Last cut of boring bar should not remove more than .0020" (.05 mm). Finish to final dimension by honing the last .0008" (.02 mm).

Piston Diameter Table

| Application | Piston O.D. In. (mm) |
|-------------------------------|------------------------------|
| Standard | 3.146-3.148 (79.93-79.98) |
| .020" (.50 mm) Oversize | 3.166-3.168 (80.43-80.48) |
| .030" (.75 mm) Oversize | 3.176-3.178 (80.68-80.73) |
| .039" (1.0 mm) Oversize | 3.186-3.188 (80.93-80.98) |

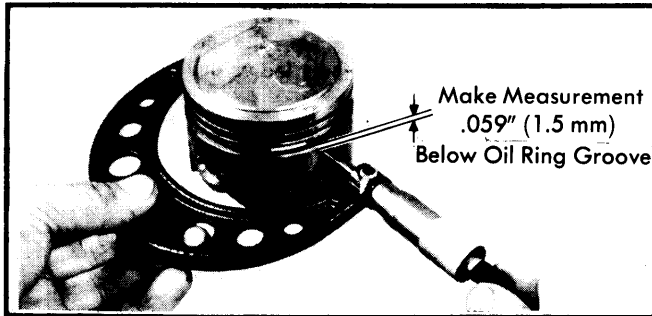

Fig. 11 Measure Piston as Shown at 68°F (20°C)

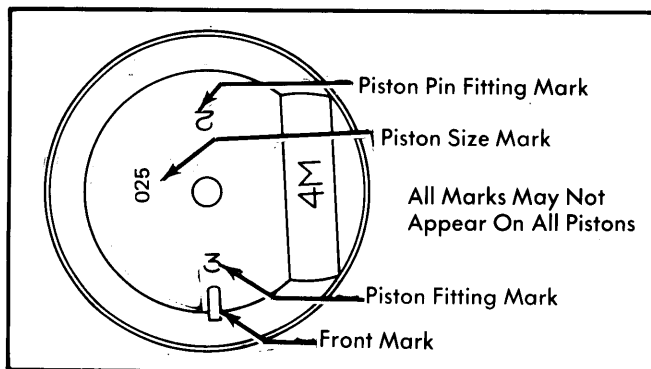

Fig. 12 Typical Reference Marks on Piston Head

NOTE — Allow bore to cool after boring and honing to avoid erroneous readings while measuring. Cool measurement of piston and bore should provide .0020-.0028" (.05-.07 mm) for proper clearance.

Removal — Remove circlips in piston pin hole with needle nose pliers. Heat piston to about 140°F (60°C) and remove pin by tapping lightly with plastic hammer. Keep piston, pin and rod together as a set.

PISTON PINS

Installation — Install one circlip in piston and heat to about 140°F (60°C). Align piston notch with rod mark and push pin in with thumb. Install remaining circlip.

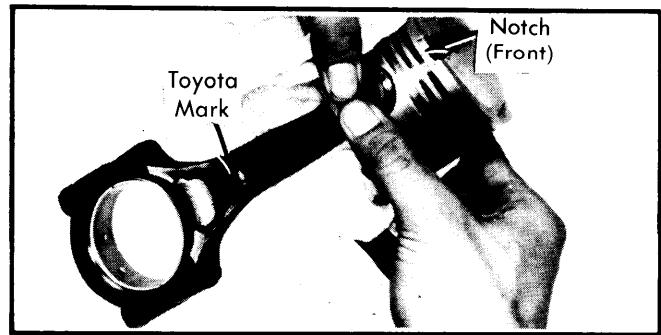

Fig. 13 Notch on Piston and Mark on Rod Must Face Same Direction When Installing Piston Pin

MAIN & CONNECTING ROD BEARINGS

1) Measure connecting rod side play with dial indicator. If greater than .012" (.3 mm), rod must be replaced. Wipe off bearing and journal, then check clearance with Plastigage. If clearance exceeds .003" (.08 mm) and cannot be corrected with .002" (.05 mm) undersize bearings, or if taper or out-of-round exceeds .0008" (.02 mm), crankshaft must be ground to next undersize.

2) Check crankshaft runout with dial indicator. If runout exceeds .0012" (.03 mm), correct or replace crankshaft. Check main bearing journal for taper and out-of-round. Check main bearing clearance using Plastigage. If required, crankshaft may be reground for undersize bearings. Undersize bearings for main and connecting rods are available in .002" (.05 mm), .010" (.25 mm) and .020" (.50 mm) as well as standard.

THRUST BEARING

Measure crankshaft end play with center (number 4) main bearing and cap installed. If clearance exceeds .012" (.3 mm), replace thrust washers to achieve standard clearance of .002-.010" (.05-.25 mm). Standard thickness of thrust washer is .115" (2.92 mm) with .005" (.13 mm) and .010" (.25 mm) oversizes available.

NOTE — Install thrust washers with oil grooves facing outward

REAR MAIN OIL SEAL

Inspect oil seal lip and replace if worn or damaged. Pry old seal out without damaging cover or retainer. Install seal using replacer tool (09223-41010). Apply multipurpose lubricant to seal lip.

ENGINE OILING

Pressure Relief Valves — There are 3 relief valves in the engine oiling system. The pressure relief valve in the oil pump opens at 71-85 psi (5.0-6.0 kg/cm²), the oil regulator valve-to-cooler opens at 38-50 psi (2.7-3.5 kg/cm²), and the relief valve in the filter opens with a pressure difference of 1-17 psi (.8-1.2 kg/cm²).

Oil Filter — Full flow spin-on type.

Crankcase Capacity — 4.9 qts. with filter, 4.3 qts. without filter.

4M-E 6 CYLINDER (Cont.)

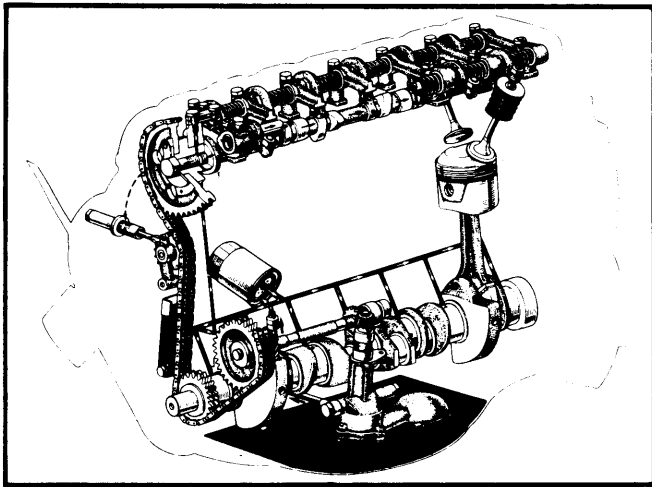

Fig. 14 Diagram of Engine Lubrication System (Oil Cooler Not Shown)

ENGINE OILING SYSTEM

System is force feed with full-flow filtering unit. Pressure is delivered by a gear-driven oil pump. From filter oil travels through cylinder block passages by which internal components are lubricated. An external oil cooler is mounted at the upper left front of the radiator. It receives oil from the regulator mounted on the block, cools and returns the oil to the pan.

OIL PUMP

With pan off engine, remove oil pump mounting bolts and take out oil pump. Disassemble pump by removing (in order) snap ring, spacer, driveshaft gear, Woodruff key, pump cover, pump shaft sub-assembly, driven gear, relief valve plug, gasket, spring and relief valve. Check side clearance between gear and cover for maximum of .006" (.15 mm). Check clearance between gear teeth and body for not more than .008" (.2 mm). Measure backlash between gear teeth with feeler gauge for no more than .035" (.9 mm). Clean and inspect components and reverse disassembly procedure. Pump may be checked for operation by immersing screen in oil and turning shaft clockwise. Oil should discharge from pump outlet.

ENGINE COOLING

Thermostat — Wax pellet type, begins to open at 176-183°F (80-84°C) and should open to more than .32" (8 mm) at 203°F.

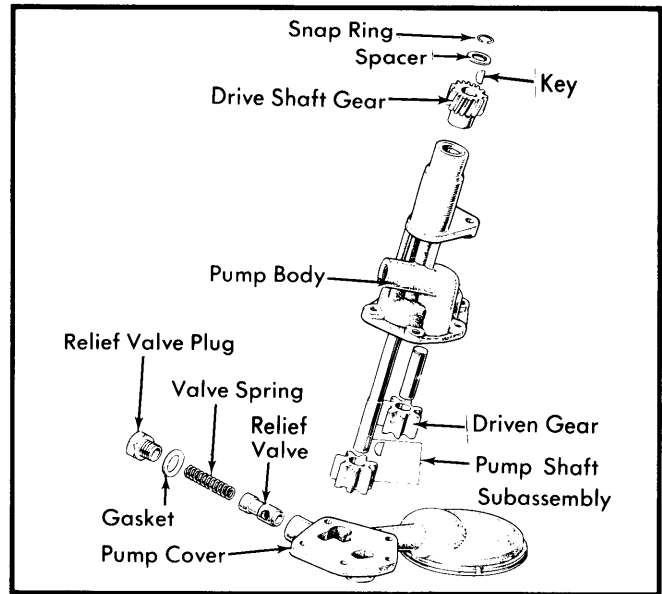

Fig. 15 Exploded View of Gear Driven Oil Pump

WATER PUMP

NOTE — It is not necessary to remove complete water pump housing to service water pump. Pump cover may be removed from housing and housing may be left on cylinder block.

Remove fluid coupling and fan assembly. Remove fan belt and pulley. Remove 5 cover bolts and take off cover assembly. Replaces seals and bearings as required. Use new gasket and reverse removal procedure.

TIGHTENING SPECIFICATIONS

| Application | Ft.Lbs. (mkg) |
|--|--------------------|
| Cylinder Head | |
| 12 mm bolts | 54-62 (7.5-8.5) |
| 8 mm bolts | 11-16 (1.5-2.2) |
| Intake Manifold | 11-15 (1.5-2.1) |
| Exhaust Manifold | 12-17 (1.7-2.3) |
| Camshaft Bearing Cap | 12-17 (1.7-2.3) |
| Camshaft Timing Gear (L.H. Thread) | 47-54 (6.5-7.5) |
| Pump Drive Shaft Gear | 7-12 (1.0-1.6) |
| Main Bearing Caps | 72-79 (9.9-10.9) |
| Connecting Rod Cap | 30-35 (4.2-4.8) |
| Oil Pan | 5-7 (.65-.95) |
| Crankshaft Pulley | 98-119 (13.5-16.5) |
| Flywheel | 51-58 (7.0-8.0) |
| Chain Tensioner | 22-29 (3.0-4.0) |

ENGINE SPECIFICATIONS

| GENERAL SPECIFICATIONS | | | | | | | | | | |
|------------------------|----------|------|------------|-----------|--------------------------|--------------|------|----|--------|----|
| Year | Displ. | | Carburetor | HP at RPM | Torque (Ft. Lbs. at RPM) | Compr. Ratio | Bore | | Stroke | |
| | cu. ins. | cc | | | | | in. | mm | in. | mm |
| 1980 | 156.4 | 2563 | Fuel Inj. | 110@4800 | 136@2400 | 8.5:1 | 3.15 | 80 | 3.35 | 85 |

4M-E 6 CYLINDER (Cont.)

ENGINE SPECIFICATIONS (Cont.)

| VALVES | | | | | | | |
|----------------|---------------------|------------|------------|------------------------|-------------------------------------|----------------------------|---------------------|
| Engine & Valve | Head Diam. In. (mm) | Face Angle | Seat Angle | Seat Width In. (mm) | Stem Diameter [ⓐ] In. (mm) | Stem Clearance In. (mm) | Valve Lift In. (mm) |
| 2563 cc Intake | | 44.5 | 45° | .047-.063 (1.2-1.6) | .3138-.3144 (7.970-7.985) | .0010-.0024 (.025-.060) | |
| Exhaust | | 44.5 | 45° | .047-.063 (1.2-1.6) | .3134-.3140 (7.960-7.975) | .0014-.0028 (.035-.070) | |

ⓐ — Wear limit for intake — .004" (.10 mm), exhaust — .005" (.13 mm).

| VALVE SPRINGS | | | |
|---------------|----------------------|------------------------------------|------------|
| Engine | Free Length In. (mm) | PRESSURE Lbs. @ In. (kg @ mm) | |
| | | Valve Closed | Valve Open |
| 2563 cc Inner | 1.77 (44.9) | 14.1-17.2@1.49 (6.4-7.8@37.9) | |
| Outer | 1.84 (46.9) | 37.3-46.5@1.63 (17.1-21.1@41.4) | |

| CAMSHAFT | | | |
|----------|----------------------------------|----------------------------|-----------------|
| Engine | Journal Diam. In. (mm) | Clearance In. (mm) | Runout In. (mm) |
| 2563 cc | 1.3378-1.3384 (33.979-33.995) | .0007-.0022 (.017-.057) | .0024 (.06) |

ⓐ — If valve spring is out of square more than .063" (1.6 mm), replace spring.

| PISTONS, PINS, RINGS | | | | | | |
|----------------------|-------------------------|---------------------|--|-------|--------------------------|--------------------------|
| Engine | PISTONS | | PINS | | RINGS | |
| | Clearance In. (mm) | Piston Fit In. (mm) | Rod Fit In. (mm) | Rings | End Gap In. (mm) | Side Clearance In. (mm) |
| 2563 cc | .0019-.0027 (.05-07) | | .0002-.0004 (.005-.011) Limit .0006 (.015) | No. 1 | .0039-.0110 (.10-.28) | .0012-.0028 (.03-.07) |
| | | | | No. 2 | .0039-.0110 (.10-.28) | .0008-.0024 (.02-.09) |
| | | | | Oil | .0079-.0200 (.20-.50) | |

| CRANKSHAFT MAIN & CONNECTING ROD BEARINGS | | | | | | | |
|---|----------------------------------|----------------------------|----------------|------------------------------|----------------------------------|----------------------------|------------------------|
| Engine | MAIN BEARINGS | | | | CONNECTING ROD BEARINGS | | |
| | Journal Diam. In. (mm) | Clearance In. (mm) | Thrust Bearing | Crankshaft End Play In. (mm) | Journal Diam. In. (mm) | Clearance In. (mm) | Side Play In. (mm) |
| 2563 cc | 2.3617-2.3627 (59.988-60.012) | .0013-.0023 (.034-.058) | No. 4 | .002-.010 (.05-.25) | 2.0463-2.0472 (51.976-52.000) | .0008-.0021 (.021-.053) | .006-.012 (.16-.30) |