

## LE CAR 4 CYLINDER

### ENGINE CODING

#### ENGINE IDENTIFICATION

Type of vehicle and engine number is marked on a number plate riveted to the left rear side of the engine block. Plate is located just below cylinder head mating surface. First five digits indicate engine type.

Engine Identification	
Application	Code
Le Car (1397 cc) .....	847-25

### ENGINE, CYLINDER HEAD & MANIFOLDS

#### ENGINE

**NOTE**— Engine and transaxle are removed as an assembly.

**Removal** — 1) Remove battery. Drain coolant from engine and radiator. Drain oil. Take out grille. Remove hood and inner fender support. Remove air cleaner.

2) Disconnect all electrical leads, control cables, vacuum lines and coolant hoses that might interfere with engine removal. Mark each item as it is disconnected. Remove transaxle cover.

3) Remove exhaust pipe flange. Remove radiator mounting nuts. Lift out radiator, cooling fan, and expansion tank. Disconnect steering shaft at flexible coupling. Do not lose rubber bushing.

4) Remove front wheels. Remove brake calipers without disconnecting hoses and support out of way. Disconnect tie rods at rack. Use suitable tool and separate upper ball joints. Remove steering gear box. Be sure to index steering box shims.

5) Remove air pump complete with bracket. Remove top transaxle bolts on bell housing. Attach hydraulic hoist to engine. Remove nuts from engine mounts. Remove shift rod support bolts.

6) Disconnect clutch cable. Remove front transaxle mounting bracket. Slide transaxle to left, then to right to free axle drive shafts. Remove engine assembly from vehicle.

**Installation** — To install, reverse removal procedure and note: Grease transaxle input shaft and axle drive shafts. Do not damage oil seals on axle drive shafts. Make sure axle drive shafts fully seat. Adjust clutch. Refit steering rubber bushing. Bleed cooling system.

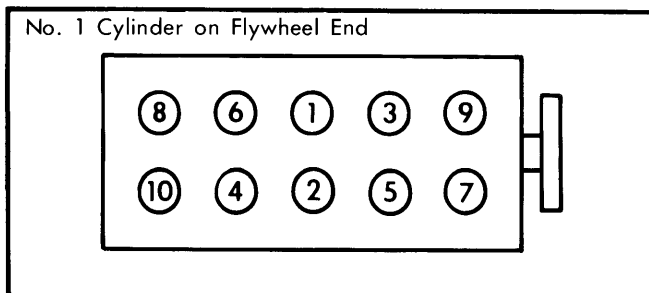

Fig. 1 Cylinder Head Tightening Sequence

#### INTAKE/EXHAUST MANIFOLD

**Removal** — Disconnect battery. Remove air filter hose. Disconnect and plug carburetor heating hose. Disconnect choke, accelerator, fuel lines and vacuum lines. Take off carburetor. Separate exhaust pipe. Remove manifold nuts and starter heat shield. Pull manifold from engine.

**NOTE** — It may be necessary to remove nut on left engine mount and tilt engine to right to gain enough clearance for removal.

**Installation** — To install, reverse removal procedure and replace all gaskets.

#### CYLINDER HEAD

**Removal** — 1) Disconnect battery. Drain cooling system. Remove air cleaner. Disconnect all hoses, vacuum lines, wires, and cables from cylinder head. Loosen air pump and take off belt. Disconnect exhaust pipe at manifold.

2) Disconnect hood lock control cable, place out of way. Take off valve cover. Remove cylinder head bolts; only loosen bolt next to distributor 1/2 turn. Tap head until free. Remove bolt and head.

**Installation** — To install cylinder head, reverse removal procedure and note: Make sure new head gasket is installed with "HAUT-TOP" facing up.

### VALVES

#### VALVE ARRANGEMENT

E-I-I-E-E-I-I-E

#### VALVE GUIDE SERVICING

1) Measure O.D. of worn guide and replace with nearest oversize. Standard valve guide O.D. is .433" (11 mm). First oversize is .437" (11.10 mm) and is identified by 1 groove mark. Second oversize is .443" (11.25 mm) and is identified by 2 groove marks.

2) Ream valve guide hole in head to accept new guide. Size of reamer must be equal to outside diameter of new valve guide. To install new guide, lightly lubricate with oil. Fit guide to press with chamfer facing out. Seat guide completely in head. Finish ream valve guide bore to accept valve.

#### VALVE SPRINGS

**Removal, Cylinder Head Installed** — Remove valve cover. Remove spark plug of cylinder requiring work. Loosen rocker arm as far as possible and remove push rod. Fit valve retaining tool in spark plug hole. Compress valve spring. Remove keepers, top cup, spring, and base washer. Check spring at free length and under a load.

**Installation** — Reverse removal procedure and note: Make sure valve spring is installed with closest coil spacing toward cylinder head.

## LE CAR 4 CYLINDER (Cont.)

### ROCKER SHAFT

After cleaning rocker shaft components, remove clips and take off springs, rocker arms, and support bearings. End plugs are press fit and cannot be removed. For correct reassembly sequence refer to Fig. 2.

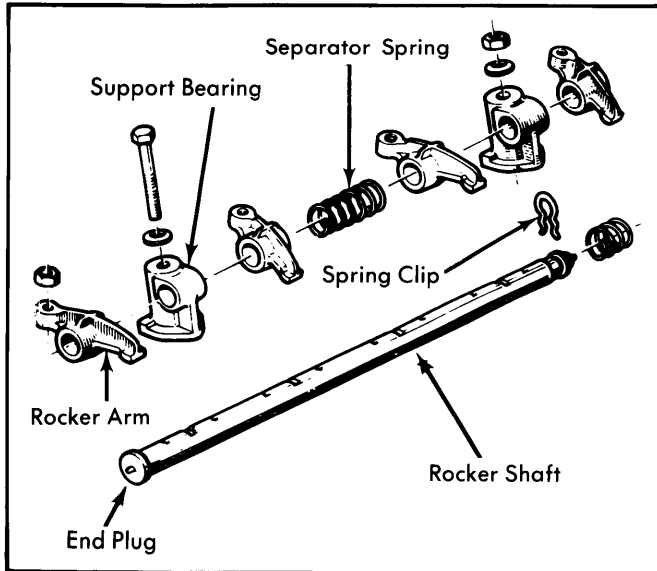

**Fig. 2 Exploded View of Rocker Arm & Shaft Assembly**

### VALVE CLEARANCE

Set intake valve clearance to .006" (.15 mm) cold or .007" (.18 mm) hot. Set exhaust valve clearance to .008" (.20 mm) cold or .010" (.25 mm) hot. Hot refers to an engine that has been operated at normal engine temperature and allowed to cool for 50 minutes.

#### Valve Adjusting Sequence

Valve Open	Valve to Adjust
No. 1 Exhaust	No. 3 Int. & No. 4 Exh.
No. 3 Exhaust	No. 4 Int. & No. 2 Exh.
No. 4 Exhaust	No. 2 Int. & No. 1 Exh.
No. 2 Exhaust	No. 1 Int. & No. 3 Exh.

### PISTONS, PINS & RINGS

#### OIL PAN

**Removal** – 1) Drain oil. Remove sway bar "U" brackets and pull bar down. Remove lower transaxle metal cover. Remove transaxle bolts that mount through gear shift bracket. Clutch protective cover must be removed.

2) Place a jack under front of transaxle to support it. Remove front pad. Raise transaxle front. Remove mounting bolts and tilt pan toward back of vehicle. Rotate crankshaft to provide clearance. Clean gasket surfaces.

**Installation** – To install, reverse removal procedure and note: Apply gasket sealer to rubber gaskets. Make sure pan side gaskets overlap bearing gaskets.

### CYLINDER LINERS

**Removal** – 1) Disconnect battery. Drain cooling system and oil pan. Remove air cleaner, cylinder head, oil pan, and oil pump. Fit liner clamp on head.

2) Index connecting rods and bearing caps. Remove connecting rod caps and bearings. Remove liner clamp and liner-piston-rod assembly.

**Installation** – 1) Check cylinder liner protrusion WITHOUT sealing "O" ring installed on liner base. Install dial indicator (Mot. 251) and measuring block (Mot. 252) as shown in Fig. 3. Protrusion must be .001-.004" (.02-.09 mm). If protrusion is incorrect, substitute a new set of liners to determine if defect is in liners or cylinder block.

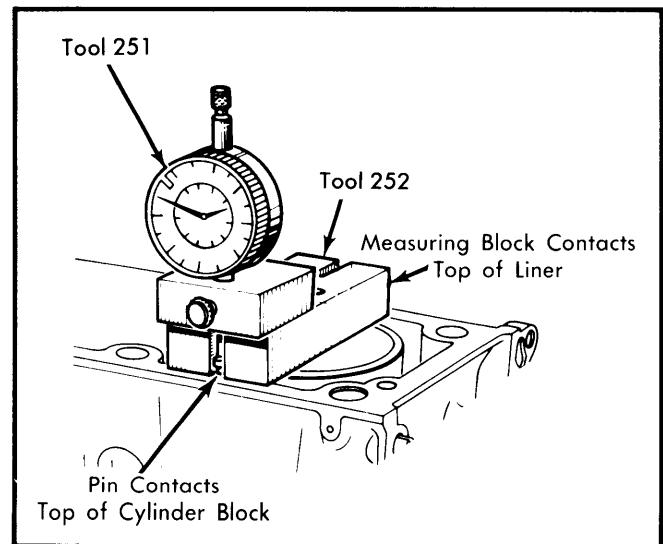

**Fig. 3 Checking Cylinder Liner Protrusion**

2) Remove liners from cylinder block and install "O" rings on base of liners. Install piston assemblies in liners.

3) Lubricate rod bearings and install liner-piston-connecting rod assemblies into block. Make sure No. 1 is at clutch end. Number on connecting rod bearing end is on opposite side of camshaft. Arrow on piston must face flywheel. Install connecting rod caps. Reverse removal procedure for remaining components.

### PISTON & ROD ASSEMBLY

**Removal** – Remove piston and rod assembly from block with cylinder liners. See *Cylinder Liners*. Remove piston out bottom of liner. Take off rings, piston pin, and connecting rod. See *Piston Pins*.

## LE CAR 4 CYLINDER (Cont.)

**Installation** — Fit piston pin. Fit rings. Piston rings are pregapped. Assemble with "O" mark or "TOP" facing up. Lubricate connecting rod assemblies with oil and fit to liner. Make sure machined side of connecting rod bearing is parallel with flat edge on liner top.

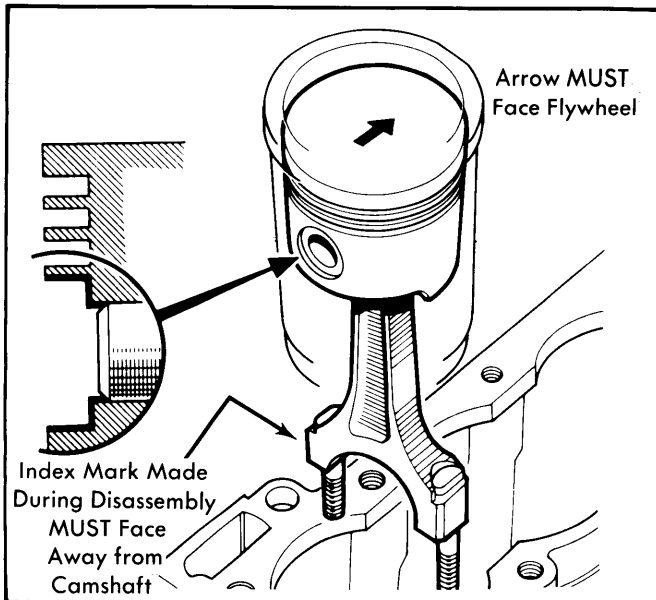

**Fig. 4 Piston Mounting and Identification Marks. Reassemble Piston and Connecting Rod Assemblies According to Illustration**

### PISTON PIN

**Removal** — Remove piston assembly from liner. Remove rings. Using suitable tool (Mot. 574), extract piston pin.

**Installation** — 1) Position piston with arrow facing flywheel. Index mark made during removal on connecting rod must face away from camshaft.

2) Heat connecting rod to 482° F (250° C). Slide new piston over installing mandrel and screw in locating plug (part of tool kit Mot. 574). Lightly oil piston pin. Push mandrel, pin guide, and pin assembly through piston by hand, until piston pin makes contact with rod. This procedure will automatically center and correctly space pin.

### CRANKSHAFT MAIN & CONNECTING ROD BEARINGS

#### MAIN BEARING SERVICE

1) Remove cylinder head and oil pan. Invert engine. Remove connecting rod bearing caps. Mark position of main bearing to block. Remove main bearing caps. Remove crankshaft, upper main bearings, and thrust washers.

2) Use a micrometer and measure crankshaft journals. If any main bearing journal is worn beyond 2.147" (54.55 mm) or any connecting rod journal is worn beyond 1.722" (43.73 mm), crankshaft must be reground and fitted with new bearings.

**NOTE** — Connecting rod journals are roll hardened. Make sure roll hardening remains intact over a 140° section facing rotational centerline of crankshaft.

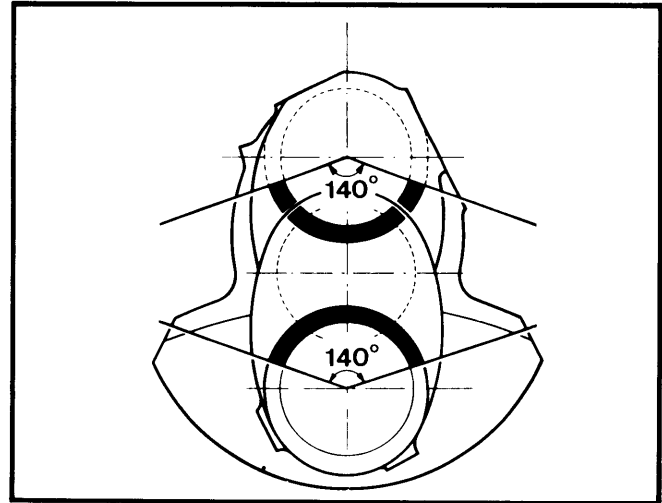

**Fig. 5 Crankshaft MUST Maintain Roll Hardened Surfaces as Shown in Illustration**

3) Fit upper main bearings. Nos. 1 and 3 are same. Nos. 2, 4, and 5 have two oil holes. Lubricate main bearing journals and fit crankshaft into position. Fit thrust washers, white metal toward crankshaft. Fit bearing to main bearing caps (those with no oil holes). Fit caps being sure to align with previously made reference marks.

4) Fit upper connecting rod bearings and slide over crankshaft. Fit lower half of bearing in cap, then tighten cap. Make sure crankshaft is free to turn.

5) Use a dial indicator and check crankshaft end play. Crankshaft should not have more than .002-.009" (.05-.23 mm) end play. Replace thrust washers if end play is beyond specification.

#### REAR MAIN BEARING OIL SEAL

**With New Crankshaft** — Fit new seal to tool Mot. 259-01 (or equivalent). Lubricate outer seal lip. Install seal in original position, seating it until tool lip just contacts cylinder block.

**With Original Crankshaft** — Offset new seal approximately 1/8" (3 mm) to position seal so it does not rest in same place original seal did. Drive seal into place with tool Mot 259-01 (or equivalent). Seal is seated when tool edge just touches block. Remove tool, insert 1/8" thick spacer, and repeat seating process. This will correctly seat seal into position.

### CAMSHAFT

#### TIMING CHAIN

**Removal** — With engine removed and suitably supported, remove timing cover. Wire tensioner shoe away from chain. See Fig. 7. Remove camshaft sprocket lock bolt. Use a puller to remove camshaft sprocket with timing chain. Chain will come off without disturbing crankshaft sprocket.

## LE CAR 4 CYLINDER (Cont.)

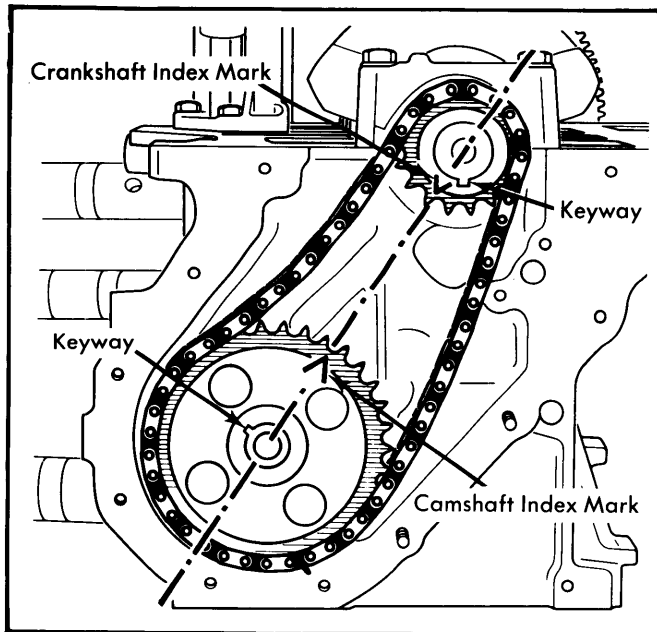

**Fig. 6** Index Mark and Keyway Positions for Timing Chain Installation (Engine Inverted)

**Installation** – 1) Position chain on camshaft sprocket. Align camshaft reference mark with one on crankshaft. Note position of camshaft and crankshaft keyway shown in Fig. 6. Using a small Allen wrench, activate tensioner mechanism.

2) Refit chain tensioner with thrust plate. Tighten mounting bolts and release load on automatic wear compensator tensioner. Release load by pressing down on bottom of tensioner body. Install new timing chain tensioner.

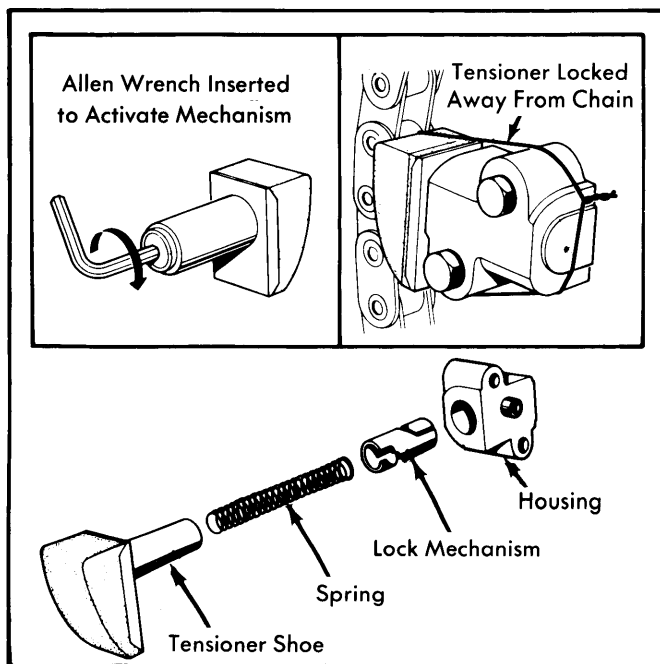

**Fig. 7** Views of Timing Chain Tensioner

### CAMSHAFT

**Removal** – Remove engine and suitably support on stand. Remove cylinder head, distributor drive gear, oil pan, timing chain cover, and timing chain. Work through access slots in camshaft sprocket and remove two flange bolts. Carefully slide camshaft from engine.

**Installation** – Check clearance between camshaft sprocket and flange. Clearance must not exceed .002-.005" (.05-.12 mm). Lubricate camshaft journals and lobes, then refit camshaft. Install flange and tighten. Refit sprocket and tighten mounting bolt. Make sure all camshaft and crankshaft alignment marks are matched. See Fig. 6. Reverse removal procedure for remaining components.

### CAMSHAFT OIL SEAL

**NOTE** – Camshaft oil seal can be changed without removing engine.

**Removal** – Remove air cleaner, air pump, pump support, and drive belt. Remove serrated pulley from camshaft. Insert tool Mot. 500-01 (or equivalent) until lip of oil seal slips over shoulder of tool. Push tool sleeve in. Tighten tool bolt clockwise until seal is removed.

**Installation** – Slip sleeve of tool over end of camshaft to spread lip of seal. Lubricate seal and slide over sleeve. Using oil seal inserting tool (part of tool Mot. 500-01), press seal inward until it just touches block. Remove sleeve. Screw threaded rod into camshaft with nut and washer at rod end. Tighten nut until tool just meets clutch housing. Replace remaining components in reverse of removal procedure.

## ENGINE OILING

**Crankcase Capacity** – 3.4 quarts with filter change.

**Oil Filter** – Disposable canister type.

**Normal Oil Pressure** – 10 psi (.7 kg/cm<sup>2</sup>) at idle speed. 50 psi (3.5 kg/cm<sup>2</sup>) at 4000 RPM.

### OIL PUMP

**Removal** – Drain oil. Remove oil pan. Take out three bolts mounting oil pump and remove pump.

**Disassembly** – Remove four pump cover bolts. Remove cover slowly; relief valve is under spring tension. Remove driven gear, drive gear, and drive gear shaft.

**Inspection** – Examine splines on drive shaft. Check ball seat for damage. Check pressure relief spring for fatigue. Check clearance between gears and body. Replace gears if clearance exceeds .008" (.2 mm).

**Reassembly** – Reverse disassembly procedure.

**Installation** – Install pump, do not use gasket between oil pump and block. Tighten mounting bolts.

# Renault Engines

## LE CAR 4 CYLINDER (Cont.)

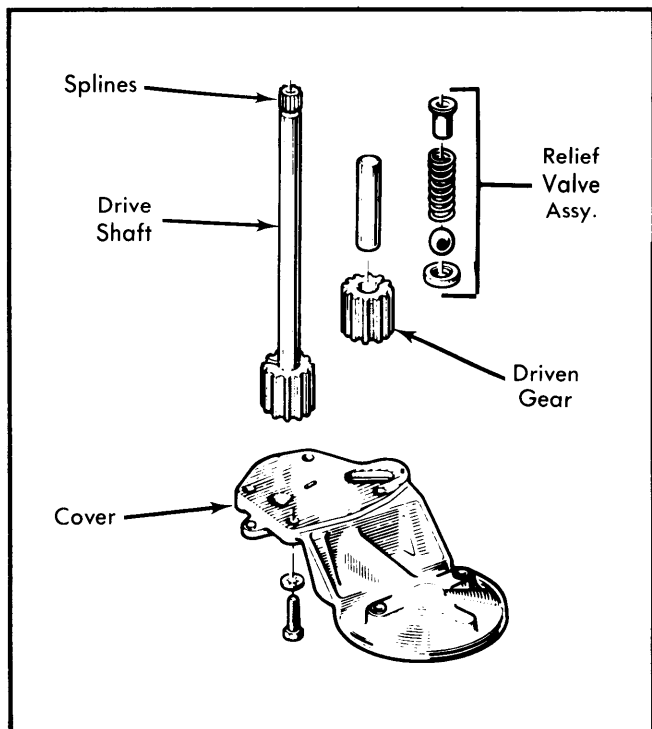

Fig. 8 Exploded View of Oil Pump Assembly

### ENGINE COOLING

#### WATER PUMP

**Removal** – Disconnect battery. Disconnect hoses. Drain block at plug near timing cover. Loosen alternator. Remove water pump drive belt. Remove A.I.R. pump, water pump pulley, grooved belt, and temperature sending unit. Remove mounting bolts and tap pump free.

**Installation** – To install, reverse removal procedure and be sure to bleed air from cooling system.

**Cooling System Capacity** – Approximately 6.5 quarts, including heater.

#### TIGHTENING SPECIFICATIONS

Application	Ft. Lbs. (mkg)
Cylinder Head Bolts	
Cold .....	40 (5.5)
Hot (After cooling 50 minutes).....	45 (6.2)
Connecting Rods.....	35 (4.8)
Main Bearings .....	40-50 (5.5-6.9)
Manifolds .....	10 (1.4)
Rocker Arm Shaft.....	10-15 (1.4-2.1)
Timing Sprocket-to-Camshaft.....	20 (2.8)

### ENGINE SPECIFICATIONS

#### GENERAL SPECIFICATIONS

Year	Displ.		Carburetor	HP at RPM	Torque (Ft. Lbs. at RPM)	Compr. Ratio	Bore		Stroke	
	cu. ins.	cc					in.	mm	in.	mm
1980	85.4	1397	1x2-Bbl.	.....	.....	8.8:1	2.99	76	3.03	77

#### VALVES

Engine & Valve	Head Diam. In. (mm)	Face Angle	Seat Angle	Seat Width In. (mm)	Stem Diameter In. (mm)	Stem Clearance In. (mm)	Valve Lift In. (mm)
1397 cc							
Int.	1.346 (34.2)	60°	60°	.043-.055 (1.1-1.4)	.276 (7)	.....	.....
Exh.	1.141 (29.0)	45°	45°	.055-.067 (1.4-1.7)	.276 (7)	.....	.....

#### PISTONS, PINS, RINGS

Engine	PISTONS		PINS		RINGS		
	Clearance In. (mm)	Piston Fit In. (mm)	Rod Fit In. (mm)	Rings	End Gap In. (mm)	Side Clearance In. (mm)	
1397 cc	.....	Free Fit	Press Fit	.....	①	.....	

① – Pre-set gap; do not alter.

# Renault Engines

5-215

E N G I N E S

## LE CAR 4 CYLINDER (Cont.)

### ENGINE SPECIFICATIONS (Cont.)

CRANKSHAFT MAIN & CONNECTING ROD BEARINGS							
Engine	MAIN BEARINGS				CONNECTING ROD BEARINGS		
	Journal Diam. In. (mm)	Clearance In. (mm)	Thrust Bearing	Crankshaft End Play In. (mm)	Journal Diam. In. (mm)	Clearance In. (mm)	Side Play In. (mm)
1397 cc	2.157 (54.80)	.....	No. 3	.002-.009 (.05-.23)	1.731 (43.97)	.....	.012-.022 (.30-.56)

CAMSHAFT			
Engine	Journal Diam. In. (mm)	Clearance In. (mm)	Lobe Lift In. (mm)
1397 cc	.....	①	.....

① - End play .002-.005" (.05-.12 mm).

VALVE TIMING				
Engine	INTAKE		EXHAUST	
	Open (BTDC)	Close (ABDC)	Open (BBDC)	Close (ATDC)
1397 cc	22°	62°	65°	25°

VALVE SPRINGS			
Engine	Free Length In. (mm)	PRESSURE Lbs. @ In. (kg @ mm)	
		Valve Closed	Valve Open
1397 cc	1.65 (42)	.....	80@1.0 (36@25)