

505 GASOLINE 4 CYLINDER

ENGINE CODING

ENGINE IDENTIFICATION

Engine serial number is stamped on left side engine mounting face and is also located on identification plate attached to top panel, above center of grille.

Engine identification number is stamped on camshaft tunnel on left side of block, near the starter. The letters at the beginning and end of the number are used for identification as follows:

| Engine Identification Codes | | |
|-----------------------------|-----------------|--------------|
| Application | Transmission | Engine Codes |
| XN6 Engine | Manual | BVM |
| XN6 Engine | Automatic | BVA |

ENGINE & CYLINDER HEAD

ENGINE

Removal – 1) Remove hood, battery and fan shroud. Drain radiator and remove upper and lower hoses. Remove electrical lead from cooling fan switch, and remove radiator lower mounting bolts. Remove rubber duct hose at mixture regulator throttle plate housing.

2) Remove fuel supply and return hoses and hose from cold start injector. Remove PCV hose and electrical connectors from cold start injector and fuel distributor. Remove fuel hoses and electrical connector from control pressure regulator.

3) Remove fuel injectors, mixture regulator and air filter. If equipped, remove air conditioning compressor and freon hose clamp near alternator. Disconnect accelerator cable and electrical harness near brake master cylinder.

4) Remove diagnostic plug for TDC sensor, located near ignition coil. Separate 2 connectors. Remove high tension lead from coil. Remove vacuum hoses from charcoal canister.

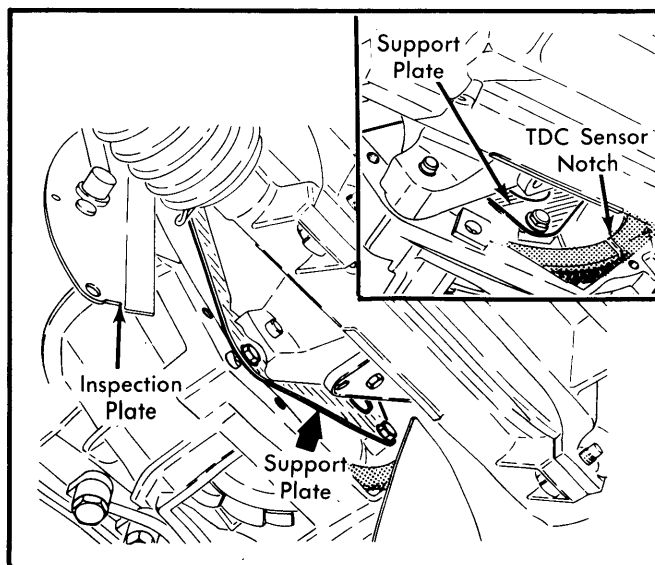

Fig. 1 Positioning Support Plate for Torque Converter

5) Remove heater hose near charcoal canister and fan. Remove oxygen sensor (Lambda) wire near vacuum switches, and disconnect air injection hose to catalytic converter. Remove vacuum switches support and 3-wire electrical connector nearby. Install engine sling assembly (8.0102-X).

6) Remove starter, clutch housing bolts, and left engine mount. Remove right engine mount. Remove 3 power steering pump bolts and set pump aside. Remove exhaust header pipe.

7) Remove inspection plates and clutch housing. On vehicles with automatic transmission, remove inspection plate without altering TDC sensor adjustment. To do so, position torque converter support plate as shown in Fig. 1. Mark TDC sensor notch in reference to support plate. Support torque converter with special clamp (8.0315-A).

8) Remove air conditioning condenser and set to left side, keeping hoses connected. Remove and set receiver-drier to one side. Lift engine with 8.0102-X engine sling assembly until top of bell housing contacts lower firewall. See Fig. 2.

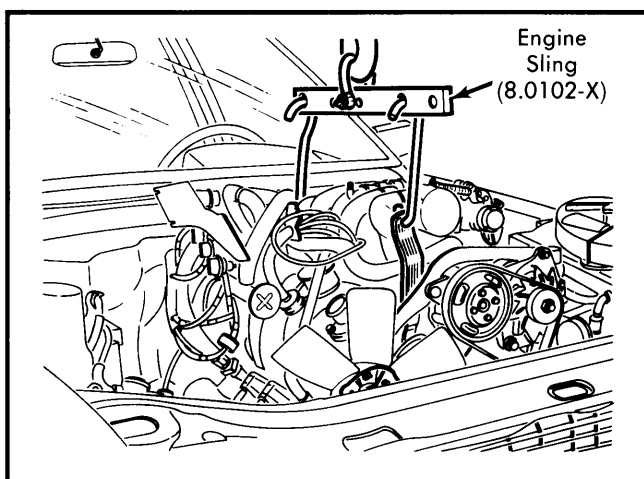

Fig. 2 Removing Engine from Vehicle

9) Install transmission supporting brace (8.0125). Disengage engine from transmission and lift engine carefully out of engine compartment. Check for electrical leads, cables, hoses or pipes which have not been detached from engine.

Installation – 1) To install engine, reverse removal procedures, noting the following precautions. On vehicles with automatic transmissions, lubricate torque converter centering nipple generously with Calysol grease (F 3015 or equivalent). Position TDC sensor notch, and align reference marks made during removal. Coat 4 torque converter bolts with normal-holding Loctite and tighten to 22 ft. lbs. (3 mkg). Use ring gear locking pawl (8.0110-J) when tightening bolts.

2) On vehicles with manual transmissions, lightly lubricate splines, front mainshaft and pilot bushing with Molykote 321 or equivalent. Place shift lever in gear. Torque engine mount-to-crossmember bolts to 22 ft. lbs. (3 mkg). Torque engine mount-to-clutch housing bolts to 40 ft. lbs. (5.5 mkg).

3) Adjust TDC sensor, if new, by bringing 3 nipples in contact. If reusing TDC sensor, deburr 3 nipples so gap of .067" (1.7 mm) exists between sensor and ring gear.

4) Refill radiator, cooling system, engine crankcase and automatic transmission. Check power steering fluid reservoir level.

505 GASOLINE 4 CYLINDER (Cont.)

5) To adjust accelerator cable, depress accelerator pedal against its stop, placing a .20" (5 mm) spacer between pedal and stop (full throttle position). Connect cable to throttle drum. Rotate drum to full throttle position. Exert slight pull on cable housing stop to place control under slight load. Install clip to obtain minimum gap between clip and common manifold.

6) To adjust kick-down cable, place throttle plate in idle position. Extend cable to obtain a maximum play of .02" (.5 mm) between cable housing stop and cable travel limiter. Tighten cable on drum.

CYLINDER HEAD

Removal – 1) Drain cooling system, including cylinder block. Disconnect battery. Remove exhaust header pipe and oxygen sensor. Remove mounting brackets for common manifold and intake manifold.

2) Pull common manifold off pipes. Remove distributor cap, injectors, and diagnostic plug bracket. Disconnect electrical connector near ignition coil and remove high tension lead from coil. Remove all clamps and wire ties from vicinity of ignition coil. Remove vacuum hoses from charcoal canister.

3) Remove air pump outlet hose at pump. Remove upper wire and lower connector from thermo-time switch. Remove sliding lug bolt from air pump-to-alternator bracket. Remove upper and lower radiator hoses. Remove heater hose and power steering reservoir.

4) Remove radiator fan shroud and fan. Using a rag, remove water pump belt from pulley. Use crankshaft pulley bolt sprocket (8.0118-PZ) to turn crankshaft counterclockwise while removing belt.

5) Remove thermostatic air slide valve bracket. Remove vacuum hoses, coolant hoses, and thermostatic wire from valve. Remove two large hoses from diverter valve. Remove bracket from valve. Remove air injection assembly.

6) Remove heater hose near dipstick and remove auxiliary air device. Remove remaining electrical connectors from switches or sensors mounted in cylinder head. Remove rocker arm oil feed pipe. Disconnect all vacuum hoses remaining on common manifold side of engine, including hose at diverter valve.

7) Remove spark plug wire brackets and wires at spark plug. Remove valve cover. Remove cooling fan brush holder. Remove sealing rings from spark plug tubes. Remove rocker arm assembly and push rods.

8) Use pivoting handles (0.0149) to break cylinder head loose. Install cylinder liner retainers (8.0132) to prevent liners from moving.

Inspection – 1) Plug passages in cylinder block for valve lifters and oil return. Clean and scrape cylinder block gasket surface, and run a tap in cylinder block bolt holes.

2) Check liner protrusion above block (.0028-.0055" or .07-.14 mm) at engine centerline. No liner should protrude more than .0015" (.04 mm) above adjacent liner. If not to specifications, replace liner gaskets.

3) Using a plastic or wooden scraper, clean cylinder head gasket surface. Clean cylinder head bolts. Check for cylinder head warpage (maximum allowable is .004" or .10 mm). Check

cylinder head thickness. Original thickness is 3.636-3.648" (92.35-92.65 mm), with minimum permissible thickness being 3.616" (91.85 mm). If cylinder head must be planed, check thickness before and after planing to be sure thickness is within tolerances.

4) Clean and check valve lifters, using caution not to mix them. DO NOT scrape carbon off piston tops, as liner damage could result.

Installation – 1) Install cylinder head in reverse of removal sequence, noting the following. When installing cylinder head, use 2 locating guides (8.0115-BZ). Install new gasket with word, "DESSUS", "ALTO" or "TOP" facing up (toward cylinder head).

2) Install cylinder head and rocker arm assembly. Lightly tighten cylinder head bolts (with flat washers), using a drop of engine oil on threads. Lightly tighten rocker shaft nuts. Remove 2 head guides, using removal tools (8.0115-A). Install last 2 head bolts.

NOTE – Do not get oil in cylinder head bolt holes, as this could cause hydraulic blockage and prevent proper tightening.

3) Using tightening sequence shown in Fig. 3, tighten head bolts to 36 ft. lbs. (5.0 mkg) and rocker shaft nuts to 11 ft. lbs. (1.5 mkg). Place angular head torquing tool (8.0129) on 2 center bolts (1 and 2). Completely loosen No. 1 bolt and retorque it to 14 ft. lbs. (2.0 mkg). Keep tool in place and maintain tension on torque wrench.

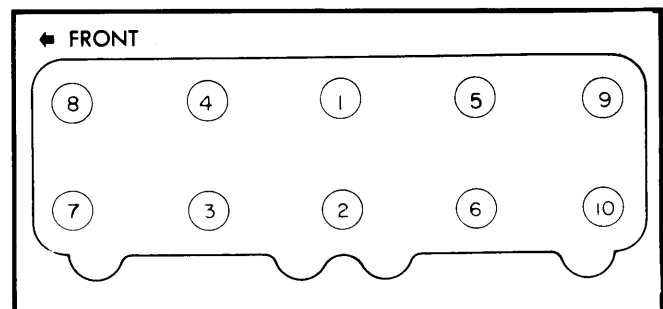

Fig. 3 Cylinder Head Bolt Tightening Sequence

4) Position pointer on tool at "0" notch by moving spring loop. Continue torquing until pointer lines up with "90" notch. Repeat entire procedure with No. 2 bolt. Then move tool and complete tightening procedure in proper sequence. If there is any doubt concerning torque of any one bolt, loosen it completely and repeat all tightening procedures for that one head bolt. Adjust valves, and complete installation. Refill cooling system.

NOTE – After cylinder head removal, adjust intake valve clearance to .006" (.15 mm) and exhaust valves to .012" (.30 mm). After 1000-1500 miles, retorque cylinder head bolts (after 6 hours of engine cooling), and adjust valve clearances to standard specifications. See Valve Clearance Adjustment.

5) Adjust air pump and alternator belt tension at idler pulley. Loosen both idler pulley mounting bolts. Apply 36 ft. lbs. (5 mkg) torque to nut directly above idler pulley. Tighten both mounting bolts. Turn engine one full turn to align belt on idler pulley. Loosen both mounting bolts and retorque to 58 ft. lbs. (8 mkg). Retighten both mounting bolts.

505 GASOLINE 4 CYLINDER (Cont.)

SPARK PLUG TUBE REPLACEMENT

Removal — With cylinder head supported, screw in plugs without springs to prevent dirt from falling into cylinder. Remove tubes using mallet or suitable extractor.

NOTE — If tubes are removed, new tubes *MUST* be inserted.

Installation — To install tubes, coat with suitable sealing compound and insert so plug caps are facing as shown in illustration. When tube is fully seated, it will protrude 2.835" (72 mm) upward from cylinder head.

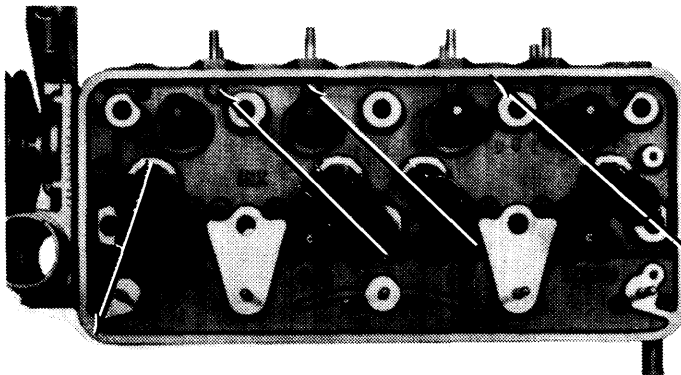

Fig. 4 Position of Spark Plug Tubes for Installation

VALVES

VALVE ARRANGEMENT

Left Side — Intake valves.
Right Side — Exhaust valves.

NOTE — Cylinders and valves are numbered with number one at flywheel end.

VALVE SPRING REPLACEMENT

Intake Valve — Turn crankshaft in direction of engine rotation and position where exhaust valve just begins to open. Slide rocker arm off intake valve then bring piston to TDC of compression stroke. Using suitable spring compressor, compress spring and remove keepers, spring retainer and spring.

Exhaust Valve — 1) Remove spark plug from cylinder requiring attention. Rotate crankshaft in direction of engine rotation and bring intake valve to fully closed position. Slide rocker arm off exhaust valve.

2) Insert suitable hinged tool (0 0136) into spark plug hole and bring piston to TDC without forcing as tool is between piston and valve. Using suitable spring compressor, compress spring and remove keepers, spring retainer and spring.

VALVE CLEARANCE ADJUSTMENT

NOTE — Engine must be allowed to cool at least 6 hours before adjusting valves. Adjust valves in firing order sequence (1-3-4-2). No. 1 cylinder is on flywheel end.

Rotate engine until exhaust valve number one is fully opened, then adjust intake valve number three and exhaust valve number four. Rotate engine one half turn until next number valve is fully opened and adjust corresponding valves. See table. Continue until all valves have been adjusted.

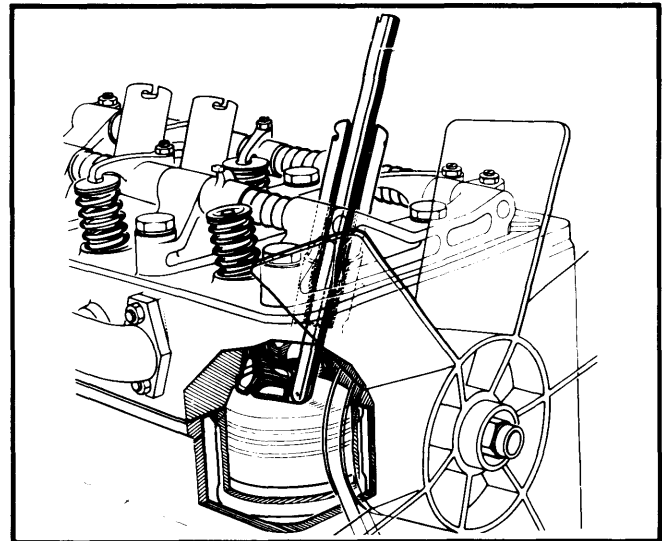

Fig. 5 Removing Valve Spring with Valve Held in Place

Valve Adjustment Sequence

| Valve Open | Adjust Valves |
|------------|---------------|
| E 1 | 1 3 & E 4 |
| E 3 | 1 4 & E 2 |
| E 4 | 1 2 & E 1 |
| E 2 | 1 1 & E 3 |

Valve Clearance Adjustment^①

| Application | Intake ^② In. (mm) | Exhaust ^③ In. (mm) |
|------------------|---------------------------------|----------------------------------|
| All Models | .004 | .010 |
| | (.10) | (.25) |

- ① — Tolerance range of +0 to +.002" (+0 to +.05 mm).
- ② — Adjust to .006" (.15 mm) after installing cylinder head. Retorque to above specifications after 1000-1500 miles.
- ③ — Adjust to .012" (.30 mm) after installing cylinder head. Retorque to above specifications after 1000-1500 miles.

PISTONS, PINS & RINGS

PISTON & ROD ASSEMBLY

NOTE — Engine must be removed to replace liners and pistons.

Removal — 1) Drain crankcase. With engine mounted on suitable engine stand, remove intake and exhaust manifolds. Remove all auxiliary equipment, including alternator, air pump and fuel pump plunger. See Fig. 6.

2) Remove cylinder head. See *Cylinder Head Removal* in this article. Remove camshaft hydraulic lifters, keeping them in original order. Remove distributor support drive shaft.

3) Remove oil pan and oil pump. Remove timing cover. Remove bearing caps, keeping them in original order. Remove pistons and connecting rods. Attach connecting rods to matching cap, mark rod assemblies 1-4.

Peugeot Engines

505 GASOLINE 4 CYLINDER (Cont.)

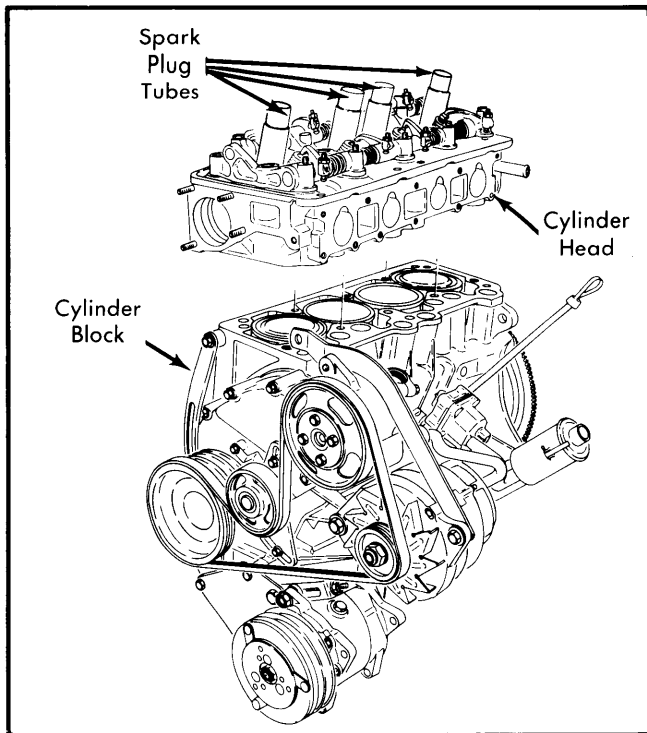

Fig. 6 Cylinder Block and Cylinder Head Assembly

Installation – 1) To install, fit piston ring clamp on piston. Insert piston and rod assembly, without twisting it. Index arrow must face front of engine.

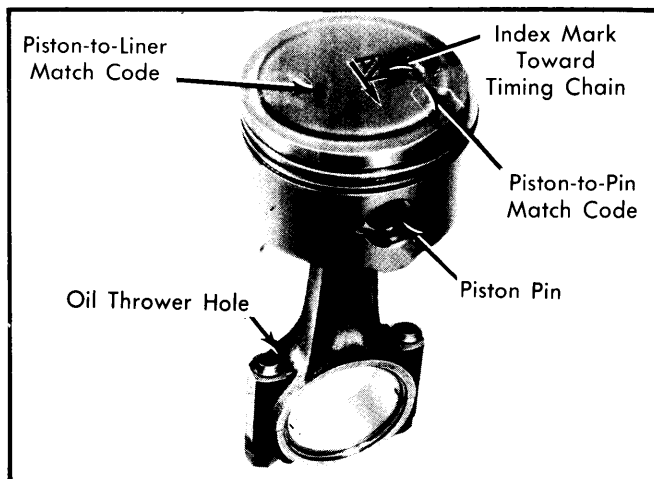

Fig. 7 Piston and Rod Assembly with Index Marks and Codes

2) Push piston down cylinder and guide connecting rod with bearing over crankshaft journal. Install bearing cap and tighten.

NOTE – Marks on rods and caps must be on same side.

PISTON PIN REPLACEMENT

Remove snap rings and piston pin. Fit piston to rod with index mark "AV" at right angle to oil thrower, so that it will face front of engine. If necessary heat piston in boiling water and insert pin. Install snap rings.

NOTE – "AV" mark on piston top must face front of engine. Pistons and liners must be matched by letter code. Number on top of piston refers to piston pin code (1 – Blue, 2 – White, and 3 – Red).

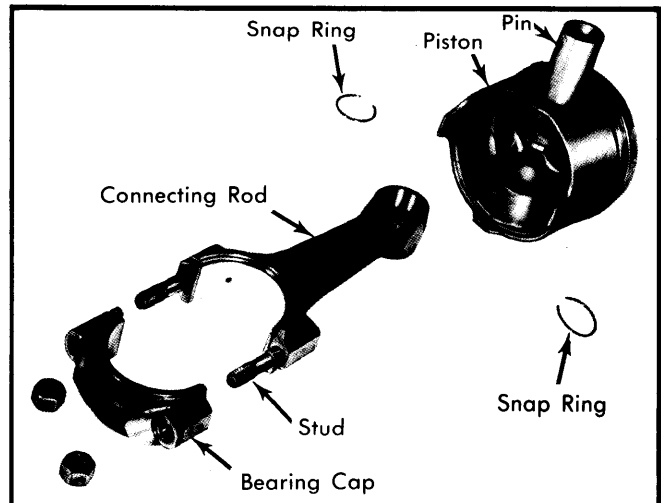

Fig. 8 Exploded View of Piston and Connecting Rod

CYLINDER LINER REPLACEMENT

1) Remove cylinder liners, using suitable extractor if required. Before installing liners, clean and inspect for burrs and dirt. Insert liners, without base gaskets, with flats on shoulder of liners 1-2 and 3-4 parallel.

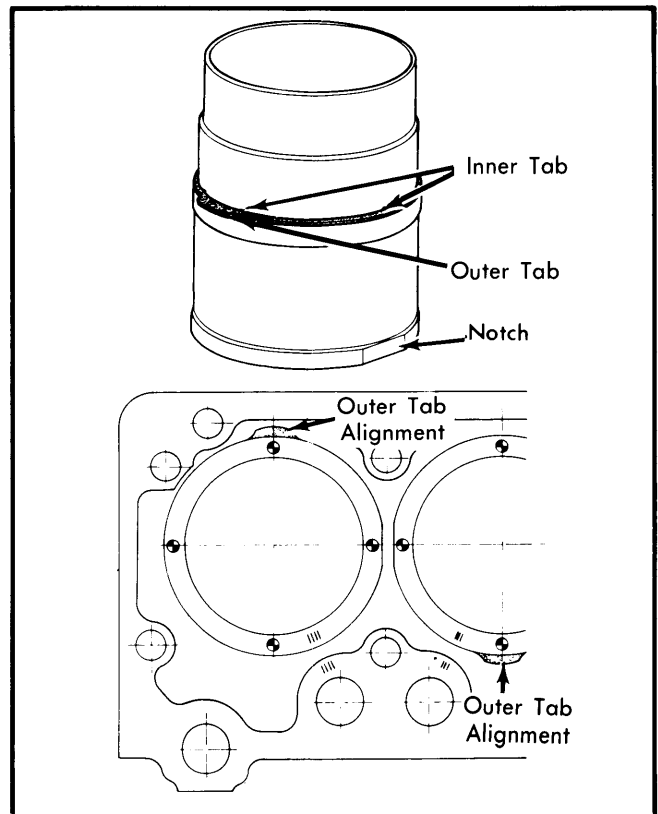

Fig. 9 Cylinder Liner Gasket Installation

505 GASOLINE 4 CYLINDER (Cont.)

NOTE — Do not alter piston/liner pairings.

2) Place a suitable dial gauge and support on block face. Synchronize dial at 0 and 5. Check each liner at 4 different points, noting the highest reading. Maximum allowable difference between 2 opposite points must be less than .003" (.07 mm). If specification is exceeded, it may be necessary to change position of liners.

NOTE — Liners must be identified by position.

3) Select a base gasket for each liner which will give a protrusion of approximately .005" (.12 mm). Gaskets are available in 4 different sizes. Use only 1 gasket on each liner.

4) Fit gasket on liner. Engage gasket inner tabs in liner grooves. See Fig. 9. Position tab with reference mark at right angles to flat. Position liners with outer tabs in position. Install suitable liner compressor tools to block. Seat liners and ensure protrusion is correct. Remove compressor tools and install liner locks.

NOTE — Difference in protrusion of adjoining cylinders must not exceed .0015" (.04 mm).

CRANKSHAFT MAIN & CONNECTING ROD BEARINGS

THRUST BEARING WASHERS

After installing crankshaft, check end play. Play must not exceed .008" (.20 mm). If specification is exceeded, oversize thrust washers are available in .094" (2.40 mm), .096" (2.45 mm), and .098" (2.50 mm) sizes.

CAMSHAFT

TIMING CHAIN

Removal — 1) Remove radiator, fan belt and spark plugs. Remove crankshaft pulley and timing chain cover. Disengage chain tensioner by removing plug and turning 3 mm Allen wrench clockwise. It is possible to further disassemble chain tensioners.

NOTE — Position camshaft as shown in Fig. 11 to avoid any possible contact of valves and pistons when rotating crankshaft with timing chain removed.

2) Remove camshaft sprocket, timing chain, crankshaft sprocket and Woodruff key.

Installation — 1) Hold crankshaft in original position and install Woodruff key and sprocket. Position camshaft and then crankshaft as shown in Fig. 12.

2) Install timing chain first on camshaft sprocket, then on crankshaft sprocket. Ensure timing marks are in correct alignment. Fit camshaft with a new washer and tighten bolts. Bend up tabs.

3) Engage chain tensioner by adjusting Allen wrench in a clockwise manner. Install a new tab washer on plug and bend tab. Withdraw tool after installing tensioner.

4) Install thrust washers (if required) and timing chain cover. Install timing chain cover on 2 centering pins, protecting seal with suitable tool. Install crankshaft pulley after cover bolts are tightened.

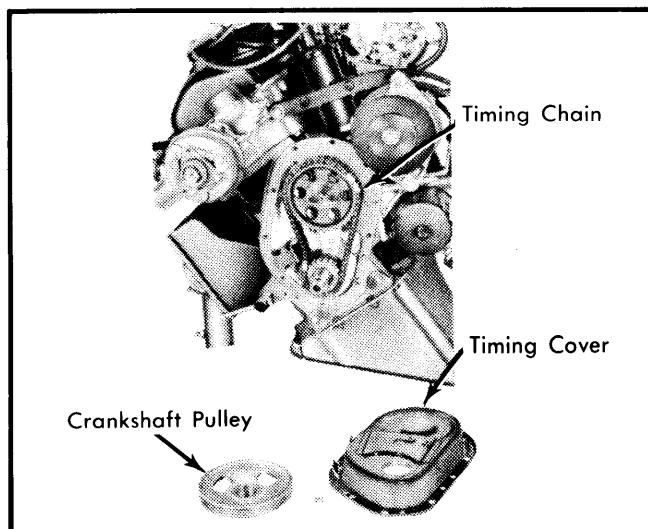

Fig. 10 Timing Cover Removed with Related Components

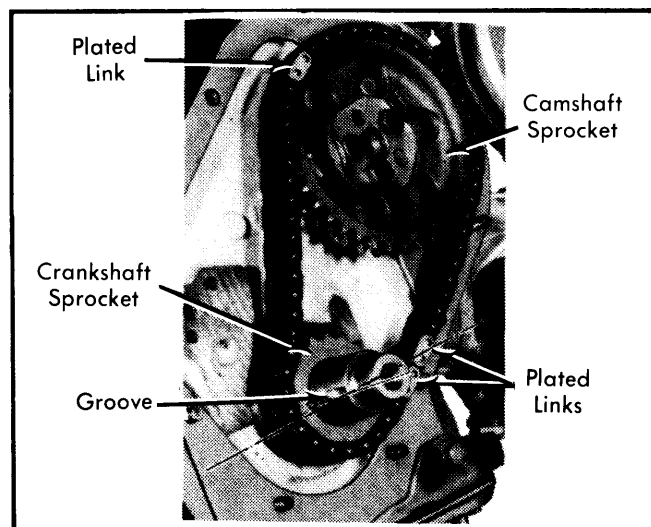

Fig. 11 Proper Alignment of Camshaft and Crankshaft for Removing Timing Chain

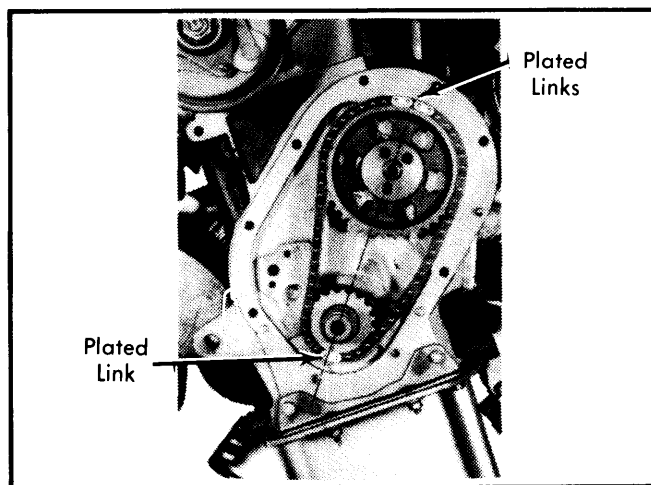

Fig. 12 Proper Alignment of Camshaft and Crankshaft

Peugeot Engines

505 GASOLINE 4 CYLINDER (Cont.)

ENGINE OILING

ENGINE OILING SYSTEM

A high output, gear type oil pump is mounted to engine block lower surface and is operated by camshaft.

Crankcase Capacity - Approximately 4.2 qts. for refill.

Oil Filter - Full-flow cartridge type.

Normal Oil Pressure - 28-51 psi (2-3.6 kg/cm²) at idle; 44-67 psi (3-4.7 kg/cm²) at 4000 RPM.

ENGINE COOLING

Thermostat - Summer - Opens at 167° F (75° C).
 Winter - Opens at 190° F (88° C).

Cooling System Capacity - Auto. Trans. - 7.7 qts.
 Man. Trans. - 7.5 qts.

Radiator Cap - 14.5 psi (1.02 kg/cm²).

WATER PUMP

Removal & Installation - Remove radiator, top hose and fan belt. Disconnect heater hose from pump and self-engaging fan brush holder. Remove water pump. To install, reverse removal procedure and ensure contact surfaces are clean before installing new gasket.

SELF-DISENGAGING FAN

Driven by water pump shaft and controlled by a thermal contact-breaker. Fan engages at approximately 190° F (88° C) and disengages at 174° F (79° C).

TIGHTENING SPECIFICATIONS

| Application | Ft. Lbs. (mkg) |
|--------------------------------------|----------------|
| Cylinder Head | See Text |
| Crankshaft Main Bearing Bolts | 54 (7.5) |
| Connecting Rod Nuts | 29 (4.0) |
| Camshaft Retaining Plate Bolts | 12 (1.7) |
| Camshaft Sprocket Bolts..... | 16 (2.25) |
| Crankshaft Pulley Bolt..... | 123 (17) |
| Oil Pan Bolts..... | 7 (1.0) |
| Flywheel-to-Crankshaft Bolts..... | 49 (6.75) |
| Engine-to-Clutch Housing..... | 16 (2.25) |
| Oil Pump Mounting Bolts..... | 7 (1.0) |
| Engine-to-Converter Housing | 22 (3.04) |
| Engine-to-Clutch Housing | 40 (5.53) |
| Engine Mounts-to-Crossmembers | 22 (3.04) |
| Oil Pump Mounting Bolts | 7 (1.0) |
| Rocker Arm Support Nuts | 11 (1.5) |
| Belt Tensioning Nut | ①58 (8.0) |

① - First step, tighten to 36 ft. lbs. (5 mkg), turn engine one full turn, and retighten to 58 ft. lbs. (8 mkg).

ENGINE SPECIFICATIONS

| GENERAL SPECIFICATIONS | | | | | | | | | | |
|------------------------|----------|------|------------|-----------|--------------------------|--------------|-------|----|--------|----|
| Year | Displ. | | Fuel Inj. | HP at RPM | Torque (Ft. Lbs. at RPM) | Compr. Ratio | Bore | | Stroke | |
| | cu. ins. | cc | | | | | in. | mm | in. | mm |
| 1980 | 120.3 | 1971 | K-Jetronic | 96@4900 | 116@3300 | 8.35:1 | 3.465 | 88 | 3.189 | 81 |

| CRANKSHAFT MAIN & CONNECTING ROD BEARINGS | | | | | | | |
|---|----------------------------------|--------------------|----------------|------------------------------|----------------------------------|---------------------------|--------------------|
| Engine | MAIN BEARINGS | | | | CONNECTING ROD BEARINGS | | |
| | Journal Diam. In. (mm) | Clearance In. (mm) | Thrust Bearing | Crankshaft End Play In. (mm) | Journal Diam. In. (mm) | Clearance In. (mm) | Side Play In. (mm) |
| 1970 cc | | | | | | | |
| No. 1 (Rear) | 2.1616-2.1646 (54.905-54.980) | ... | Rear | .003-.008 (.08-.20) | 2.1123-2.1131 (53.652-53.673) | .0006-.003 (.016-.076) | |
| No. 2 | 2.2102-2.2112 (56.140-56.165) | | | | | | |
| No. 3 | 2.2509-2.2515 (57.174-57.189) | | | | | | |
| No. 4 | 2.3050-2.3060 (58.548-58.573) | | | | | | |
| No. 5 (Front) | 2.3386-2.3392 (59.401-59.416) | | | | | | |