

280 6 CYLINDER

ENGINE CODING

ENGINE IDENTIFICATION

Engine number is stamped on front left side of cylinder block. Engine is a six cylinder double overhead cam type referred to as an M110.

Engine Identification		
Application	Chassis Type	Engine Coding
280E	123.033	110.984
280CE	123.053	110.984
280SE	116.024	110.985

ENGINE, CYLINDER HEAD & MANIFOLDS

ENGINE

NOTE — Engine and transmission must be removed as a unit. On 123 series vehicles, engine hood does not have to be removed. The hood can be opened to a 90° position and held in place by a locking mechanism on the left hinge.

Removal & Installation — 1) Remove radiator and fan. On vehicles with level control, remove pump from engine and set aside with hoses connected. On vehicles with air conditioning, remove compressor and set aside without disconnecting refrigerant hoses.

2) Drain oil supply tank and disconnect power steering hoses from pump. Remove retaining ring from longitudinal accelerator shaft and push toward firewall to remove.

3) Disconnect all water, vacuum, oil and electrical lines leading to engine. Disconnect exhaust pipes from manifold and strut on transmission. Attach suitable lifting sling and remove engine mounting hardware. Lift engine from vehicle at a 45° angle. To install, reverse removal procedures.

INTAKE MANIFOLD

Removal — Partially drain radiator and remove air cleaner. Disconnect electrical wires, water hoses and vacuum lines. Disconnect cold start valve and remove linkage. Remove attaching screws and remove intake manifold.

Installation — To install, reverse removal procedure, using a new gasket.

CYLINDER HEAD

NOTE — Cylinder head may only be removed after engine has cooled down. Head is removed complete with manifolds and camshaft housing.

Removal — 1) Drain cooling system. Remove A/C compressor (leave lines connected) and level control oil pump for models so equipped. Remove both camshaft housing front covers.

2) Remove cover and vacuum pump from front of camshaft housing. Disconnect all electrical leads, water hoses and vacuum lines from cylinder head and manifold.

3) Remove longitudinal regulating linkage and EGR line. Disconnect oil return line at cylinder head. Loosen hose between water pump and thermostat housing. Disconnect bypass line at water pump.

4) Loosen dipstick guide tube at cylinder head and bend slightly to the side. Disconnect exhaust pipes at manifold and transmission. Remove preheater scoop. Using a screwdriver, force out rocker arm tension springs. Using suitable tool (110 589 04 61 00), remove all rocker arms.

5) Rotate crankshaft until both camshaft timing marks are correctly aligned with crankshaft at TDC on firing stroke. Using suitable holding wrench (116 589 01 01 00), remove both camshaft sprocket bolts.

6) Remove upper slide rail and pull out bearing bolts with suitable extractor (116 589 20 33 00). Remove chain tensioner. Push both camshafts to rear and remove sprockets.

7) Using suitable extractor, pull out bearing pins and remove idler pulley. Extract guide rail bearing pins and remove guide rail.

8) Loosen head bolts in reverse of tightening order. Remove two 8mm bolts in chain box with a magnet, do not drop washers into timing cover. Pull up timing chain and force tension rail toward center of engine. Using two men, lift cylinder head vertically from cylinder block.

Installation — 1) Place head gasket on cylinder block. Lay two pieces of wood, ½"x1¾"x9½" long, upright between cylinders one and two and flat between cylinders five and six. Mount cylinder head at an inclined position, so that timing chain and tensioner rail can be installed.

2) Lift cylinder head and carefully remove wooden pieces. Lower head carefully, ensuring that front and rear dowels are properly engaged. Insert lubricated head bolts and tighten in 2 stages according to sequence shown in Fig. 7. Insert and tighten 8 mm bolts in chain box with Allen wrench.

NOTE — After tightening all head bolts, camshaft should be free to turn by hand.

3) Install lower slide rail and idler sprocket. Place spacer on intake camshaft journal. With engine at TDC, install camshaft sprockets with timing marks aligned.

NOTE — TDC mark on vibration damper is next to dowel pin.

4) Place spacers in front camshaft bearing of both camshafts. Install camshaft sprocket bolts, but do not tighten. Install upper slide rail and rigid chain tensioner. Using suitable holder tool (116 589 01 01 00), tighten expansion bolts.

5) Rotate engine two revolutions and recheck camshaft timing marks. Install swing lever and tensioner springs. Install chain tensioner and adjust valve clearances. Retighten head bolts after engine has been warmed to 176°F (water temperature). Tighten by first loosening head bolts a ¼ of a turn, one at a time and tighten in tightening order. Retighten 8mm bolts in chain box.

NOTE — Further tightening of head bolts after 300-500 miles is no longer required. It is not necessary to recheck valve clearances after final tightening of head bolts.

280 6 CYLINDER (Cont.)

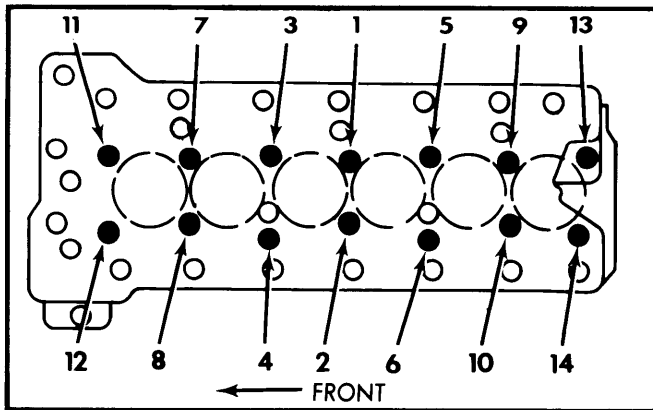

Fig. 1 Cylinder Head Tightening Sequence (Remove in Reverse Sequence)

CAMSHAFT

TIMING CHAIN

1) Remove spark plugs and cylinder head cover. Remove rocker arms of right hand (exhaust) camshaft. Remove chain tensioner and install rigid chain tensioner (110 589 03 31 00).

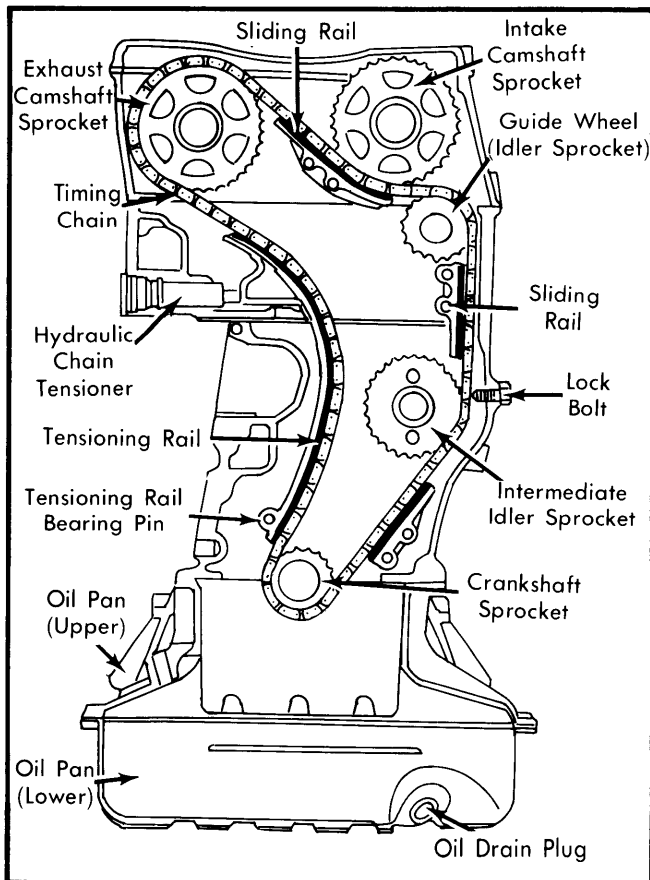

Fig. 2 Front View of Timing Chain and Sprockets

2) Cover chain box with a rag, using a chain breaker, separate chain. Join ends of new and old chains together with a master link. Rotate crankshaft in direction of rotation and pull old chain out of engine. Use care that chain does not jump a tooth on sprockets.

CAUTION — Do not turn engine by camshaft bolts. Do not rotate crankshaft in reverse.

3) Join ends of new chain. Rotate crankshaft and check timing marks. Replace rigid chain tensioner with normal chain tensioner. Install rocker arms and adjust exhaust valve clearance. Install camshaft cover and spark plugs.

CAMSHAFT & CAMSHAFT HOUSING

Removal — 1) Remove battery and A.I.R. pump. Disconnect air conditioning compressor and set aside with hoses connected. Drain radiator and remove hose between radiator and engine. Remove camshaft cover.

2) Remove camshaft sprocket covers from front of housing. Pry all rocker arm tension springs from rocker arms. Using a suitable tool (110 589 04 61 00), remove all rocker arms.

3) Using suitable holding tool (116 589 01 01 00), remove right-hand camshaft sprocket bolt. Set number one piston to TDC on firing stroke with both camshaft timing marks aligned. Remove chain tensioner.

4) Remove slide rail in camshaft housing, using suitable puller (115 589 19 33 00). Remove rear right-hand camshaft cover. Push camshaft to the rear, using suitable tool (110 589 03 33 00), while holding camshaft sprocket in place. Remove sprocket and slide camshaft back in place.

5) Remove head bolts, shown in illustration, in reverse of tightening sequence. Do not remove bolts marked with an "x" in illustration. Remove camshaft housing and camshafts.

NOTE — Camshaft housing may only be removed after engine has cooled down.

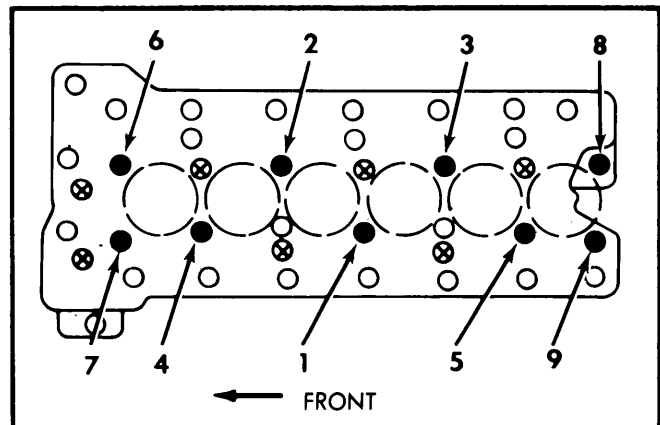

Fig. 3 Camshaft Housing Tightening Sequence (Remove ONLY Numbered Bolts in Reverse Sequence)

6) Remove left-hand camshaft sprocket in same manner as right-hand sprocket. Remove spacer ring at intake camshaft and slide both camshafts out rear of housing.

280 6 CYLINDER (Cont.)

Installation — Install steel gasket on cylinder head without sealing compound. Place camshaft housing on head. Oil head bolts and tighten to 29 ft. lbs. (4.0 mkg), then to 51 ft. lbs. (7.0 mkg). Loosen 5 deeper head bolts slightly, then tighten all head bolts to final torque in sequence shown in Fig. 1. Tighten the 8 mm bolts to 18 ft. lbs. (2.5 mkg) working from center outward.

CAMSHAFT BEARINGS

If camshaft bearing journals are worn, damaged or have excessive clearance in camshaft housing bearings, camshaft journals may be ground undersize and a repair housing installed.

Front bearing journal is not ground and remains standard. See "a" in Fig. 4. Journal should be fitted with a spacer sleeve. Camshafts do not have to be ground or replaced because of rough surfaces or bearings.

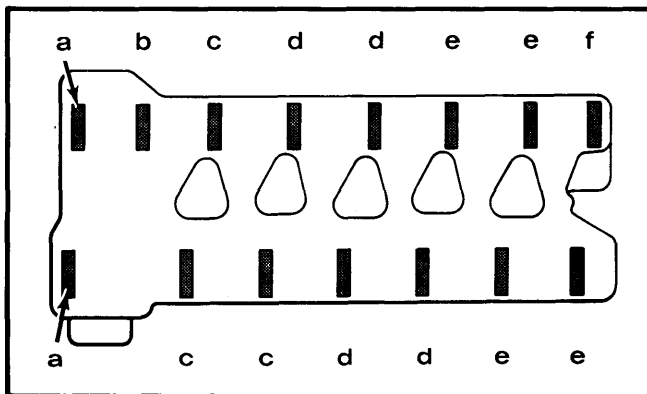

Fig. 4 Camshaft Housing Bearing Identification

VALVE TIMING

Rotate crankshaft until number one piston is at TDC on firing stroke. Both camshaft timing marks should be aligned with marks on camshaft housing. Offset woodruff keys are available to make corrections to timing. Remember that camshaft sprockets rotate in opposite directions, they rotate toward each other.

NOTE — Some balance discs have two "O" degree marks. TDC is next to a dowel pin.

Offset Woodruff Keys

Offset	Part No.	Correction
.0275" (.7 mm)	621 991 04 67	4°
.0354" (.9 mm)	621 991 02 67	6.5°
.0433" (1.1 mm)	621 991 01 67	8°
.0511" (1.3 mm)	621 991 00 67	10°

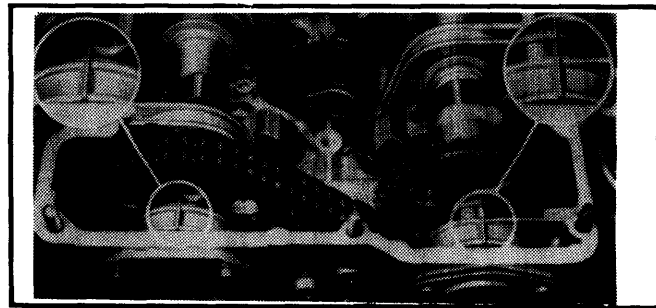

Fig. 5 Camshaft Timing Marks with No. 1 Piston at TDC on Firing Stroke

VALVES**VALVE ARRANGEMENT**

Right Side — All exhaust.

Left Side — All intake.

VALVE GUIDE SERVICING

1) Using a suitable drift, drive valve guide out top of cylinder head. Inspect guide bore in cylinder head, drive new standard guide in until lock ring touches head, if head condition permits.

2) If standard valve guide is not tight in head, ream cylinder head and install oversize valve guide. Heat cylinder head to 194°F and chill valve guide. Drive new guide in until lock ring touches head.

Valve Guide Specifications

Application	Guide O.D. In. (mm)	Head I.D. In. (mm)
Intake		
Std.	.5523-.5331 (14.03-14.05)	.5519-.5527 (14.02-14.04)
1st O.S. (red)	.5594-.5602 (14.21-14.23)	.5590-.5598 (14.20-14.22)
2nd O.S. (white)	.5673-.5681 (14.41-14.43)	.5669-.5677 (14.40-14.42)
Exhaust		
Std.	.5917-.5925 (15.03-15.05)	.5913-.5921 (15.02-15.04)
1st O.S. (red)	.5988-.5996 (15.21-15.23)	.5984-.5992 (15.20-15.22)
2nd O.S. (white)	.6066-.6074 (15.41-15.43)	.6062-.6070 (15.40-15.42)

VALVE STEM OIL SEALS

With valve springs removed, pull off old seal. Place assembly sleeves over intake valve stems and slide new valve stem seal over valve stems. Remove assembly sleeve and force seal over end of valve guide with installation mandrel.

VALVE SPRINGS

1) With camshaft housing removed, place piston on TDC of cylinder from which springs are to be removed. Install a compressed air line to spark plug hole to pressurize valves.

2) Remove valve thrust pieces. Attach suitable holding rail (110 589 06 62 00) to cylinder head. Lightly tap valve collars to loosen keepers. Install suitable spring compressor and press down on springs. Remove valve keepers and release pressure on springs. Remove inner and outer springs and check for wear or fatigue. To install, reverse removal procedures with close wound coils (color coding) next to cylinder head.

ROCKER ARM & STUD ASSEMBLY

1) With a screwdriver, pry out rocker arm tensioner springs. Using crankshaft, rotate engine until heel of cam lobe is next to rocker arm. Using suitable tool (110 589 04 61 00), remove rocker arm.

2) Unscrew threaded bushing with valve adjusting screw. Lubricate threads of adjusting screw with tallow and check that screw has at least 14.5 ft. lbs. of turning torque in bushing.

280 6 CYLINDER (Cont.)

3) Install threaded bushing and adjusting screw in cylinder head. Lubricate rocker arm and pivot. Using suitable tool (110 589 04 61 00), install rocker arms and tensioner springs. Readjust valve clearances.

CAUTION — Do not rotate engine by camshaft sprocket bolts. Do not rotate engine in reverse as camshaft sprocket may jump time.

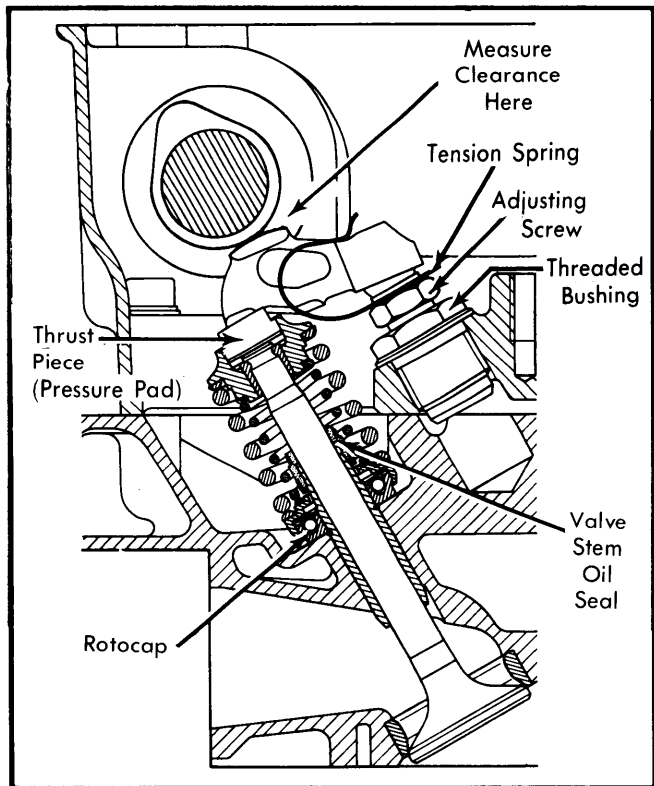

Fig. 6 Sectional View of Rocker Arm and Valve Assembly

VALVE CLEARANCE ADJUSTMENT

Rotate crankshaft until heel of camshaft lobe is next to rocker arm. Insert a feeler gauge between camshaft and rocker arm. Turn adjusting screw until proper clearance is achieved.

NOTE — Valves should be adjusted with engine at normal operating temperature. Cold specifications are provided for initial settings after assembly.

Valve Clearance

Application	In. (mm)
Intake	
Hot.....	⓪.006 (.15)
Cold.....	⓪.004 (.10)
Exhaust	
Hot.....	.012 (.30)
Cold.....	.010 (.25)

⓪ — Winter Clearance, add .002" (.05mm).

PISTONS, PINS & RINGS

OIL PAN

NOTE — A 2 piece oil pan is used. Due to complexity of operation, engine assembly must be removed to remove complete oil pan.

Removal & Installation — To remove lower oil pan, drain engine oil, remove mounting bolts and separate lower pan from upper section. To install, use sealant on clean mating surface, use new gasket and reverse removal procedure.

PISTON & ROD ASSEMBLY

Removal — With oil pan and cylinder head removed, remove rod caps and push piston and rod assembly out top of cylinder. Remove wrist pin locks and push out wrist pins. Clean and inspect all parts.

Installation — 1) Place piston on connecting rod so that arrow faces forward and recess for bearing insert is facing rear of engine. Install piston and rod assembly in cylinder. Install rod cap with code numbers facing rod numbers.

2) Rod bolts should be checked for minimum diameter with a pair of sharp edged calipers. If diameter is less than .283", replace rod bolts. Tighten rod bolts to 36 ft. lbs. and then tighten an additional 100° of rotation.

FITTING PISTONS

Measure cylinder bores near top, bottom, and center in at least 2 directions. If greater than .004" (.10 mm) from standard, cylinders must be bored and new pistons fitted.

Cylinder Bore Specifications

Application	In. (mm)
Standard.....	3.3858-3.3866 (86.0-86.02)
1st Oversize.....	3.4055-3.4063 (86.50-86.52)
2nd Oversize.....	3.4252-3.4260 (87.0-87.02)

PISTON PINS

Piston pins are retained with circlips in pistons. To remove pins, remove circlips and press out piston pins. To install, ensure that arrow on piston crown faces front (timing chain end) and that bearing retaining notch in connecting rod faces left (intake manifold) side of engine. Lubricate pin and press into piston/rod assembly by hand.

NOTE — Do NOT heat piston to install piston pin.

CRANKSHAFT MAIN & CONNECTING ROD BEARINGS

MAIN & CONNECTING ROD BEARINGS

1) Remove connecting rod and main bearing caps. Check all bearing journals for wear, taper or out-of-round. The following table gives maximum dimensions which are permissible without repair or new bearings.

Crankshaft Specifications

Application	In. (mm)
Out-of-Round.....	.0002 (.005)
Journal Taper.....	.0004 (.010)
Journal Flatness.....	.0006 (.015)
Bearing Bore Out-of-Round.....	.0004 (.010)
Bearing Bore Taper.....	.0004 (.010)

2) Bearing inserts for both main and connecting rod journals are color coded. Main bearing inserts with no color are thicker than ones which are blue. Connecting rod inserts with red color are thicker than ones with blue color. Select inserts which will give the mean of clearance range.

280 6 CYLINDER (Cont.)

Crankshaft Journal Diameters

Application	Main Bearing In. (mm)	Connecting Rod In. (mm)
Std.	2.3602-2.3606..... (59.95-59.96).....	1.8878-1.8882 (47.95-47.96)
1st U.S.	2.3504-2.3508..... (58.70-59.71).....	1.8779-1.8783 (47.70-47.71)
2nd U.S.	2.3405-2.3409..... (59.45-59.46).....	1.8681-1.8685 (47.45-47.46)
3rd U.S.	2.3307-2.3311..... (59.20-59.21).....	1.8583-1.8587 (47.20-47.21)
4th U.S.	2.3209-2.3213..... (58.95-58.96).....	1.8484-1.8488 (46.95-46.96)

Bearing Insert Wall Thickness

Application	Main Bearing In. (mm)	Connecting Rod In. (mm)
Std.1378 (3.50).....	.0713 (1.81)
1st U.S.1429 (3.63).....	.0764 (1.94)
2nd U.S.1476 (3.75).....	.0811 (2.06)
3rd U.S.1528 (3.88).....	.0858 (2.18)
4th U.S.1575 (4.00).....	.0909 (2.31)

THRUST BEARING ALIGNMENT

Install number three main bearing and measure clearance between bearing and crankshaft sides. If clearance is excessive, install new bearing. New bearings are supplied in oversize widths and must be lapped on non-thrust side to achieve proper clearance. Lap only side away from flywheel.

REAR MAIN BEARING OIL SEAL

Press pieces of seal into cylinder block and oil pan with a wooden hammer handle. Cut ends of seal so they protrude .020" (.5 mm) above parting surfaces. Oil seal halves liberally and install crankshaft and oil pan. Check for easy rotation of crankshaft and reassemble engine.

FRONT COVER OIL SEAL

1) Remove radiator and fan, pulley and vibration damper. Mark balance disc and crankshaft with punch for assembly purposes. Use suitable puller and remove balance disc.

2) Pry old seal out with screwdriver, using caution not to damage seal bore or crankshaft journal. Clean and inspect seal bore and apply oil to new seal (do NOT use sealing compound). Press seal into position with installing tool (110 589 07 61 00).

3) Install new spacing ring or turn used ring around so that worn groove is at rear. Install remaining components in reverse order of assembly.

ENGINE OILING

Crankcase Capacity — 6.3 qts. (including filter).

Oil Filter — Full flow type.

Normal Oil Pressure — 7.1 psi (.5 kg/cm²) at 800-900 RPM;
42 psi (3 kg/cm²) at 3000 RPM.

Pressure Regulator Valve — Nonadjustable.

ENGINE OILING SYSTEM

Oil is drawn from the oil pan by a gear type oil pump and pressure fed through a full-flow oil filter to crankshaft main bearings. Passages drilled in crankshaft carry oil to connecting rod bearings. A passageway drilled longitudinally through the connecting rod carries oil from connecting rod bearing to wrist pin bushing. A further passageway carries oil to intermediate shaft, oil pump, and distributor drive gears. This passageway also lubricates camshaft bearings, cam lobes, rocker arms, idler sprocket, and chain tensioner.

OIL PUMP

Remove fuel pump and lower half of oil pan. Remove screws from crankcase and main bearing cap. Pull out oil pump. Disassemble, clean and inspect oil pump. To install, reverse removal procedure.

ENGINE COOLING

Cooling System Capacity — 280E, 280CE — 10.6 qts.
280SE — 11.6 qts.

Thermostat — Opens at 185-193°F (85-89°C).

WATER PUMP

Drain radiator and disconnect water hoses. Loosen radiator shell and remove radiator. Remove fan and fan clutch (store in upright position). Remove all drive belts. Remove six Allen screws attaching pulley and vibration damper. Withdraw pulley and damper. Remove water pump. To install, reverse removal procedure.

TIGHTENING SPECIFICATIONS

Application	Ft. Lbs. (mkg)
Main Bearings	58 (8.0)
Connecting Rods	①36 (5.0)
Crankshaft Bolt	289-325 (40-45)
Camshaft Cover	4 (.5)
Cylinder Head Bolts	
Stage 1	51 (7.0)
Stage 2	72 (10)
Stage 3②	72 (10)
Camshaft Bolt	72 (10)
Oil Pump	21 (3.0)
Chain Tensioner Nut	36 (5.0)
① — Tighten bolts to 36 ft. lbs. (5 mkg) and then turn bolts an additional 100° of rotation.	
② — With engine warm (176°F or 80°C), loosen all head bolts ¼ turn in tightening sequence, then tighten to final torque.	

ENGINE SPECIFICATIONS

GENERAL SPECIFICATIONS										
Year	Displ.		Carburetor	HP at RPM	Torque (Ft. Lbs. at RPM)	Compr. Ratio	Bore		Stroke	
	cu. ins.	cc					in.	mm	in.	mm
1980	167.6	2746	Fuel Inj.	140@5500	145@4500	8.0-1	3.39	86	3.10	78.8

Mercedes-Benz Engines

5-157

ENGINES

280 6 CYLINDER (Cont.) ENGINE SPECIFICATIONS (Cont.)

VALVES							
Engine & Valve	Head Diam. In. (mm)	Face Angle	Seat Angle	Seat Width In. (mm)	Stem Diameter In. (mm)	Stem Clearance In. (mm)	Valve Lift In. (mm)
2746 cc Intake	1.775-1.783 (45.1-45.3)	45°	45°	.071-.098 (1.8-2.5)	.3524-.3531 (8.95-8.97)	.0019 (.05)
Exhaust	1.5315-1.5354 (38.9-39.0)	45°	45°	.059-.079 (1.5-2.0)	.3520-.3528 (8.94-8.96)	.0023 (.06)

PISTONS, PINS, RINGS						
Engine	PISTONS		PINS		RINGS	
	Clearance In. (mm)	Piston Fit In. (mm)	Rod Fit In. (mm)	Rings	End Gap In. (mm)	Side Clearance In. (mm)
2746 cc	.0010-.0014 (.025-.035)	.00008-.0004 (.002-.011)	.0003-.0007 (.007-.017)	No. 1	.012-.018 (.30-.45)	.0019-.0032 (.050-.082)
	No. 2			.012-.018 (.30-.45)	.0011-.0024 (.030-.062)	
	No. 3			.010-.016 (.25-.40)	.0004-.0016 (.010-.042)	
	Limit .003 (.08)					

CRANKSHAFT MAIN & CONNECTING ROD BEARINGS							
Engine	MAIN BEARINGS				CONNECTING ROD BEARINGS		
	Journal Diam. In. (mm)	Clearance In. (mm)	Thrust Bearing	Crankshaft End Play In. (mm)	Journal Diam. In. (mm)	Clearance In. (mm)	Side Play In. (mm)
2746 cc	2.3602-2.3606 (59.95-59.96)	.001-.002 (.03-.05)	No. 3	.004-.009 (.10-.24)	1.8878-1.8882 (47.95-47.96)	.0005-.0020 (.013-.050)	.004-.009 (.10-.24)

VALVE SPRINGS			
Engine	Free Length In. (mm)	PRESSURE Lbs. @ In. (kg @ mm)	
		Valve Closed	Valve Open
2746 cc	1.772 (45)	26.01@1.299 (11.8@33)	50.7@.846 (23@21.5)
		Outer 1.949 (49.5)	67.24@1.6535 (30.5@42)

CAMSHAFT [Ⓢ]			
Engine	Journal Diam. In. (mm)	Clearance In. (mm)	Lobe Lift In. (mm)
2746 cc	a	.9441-.9445 (23.98-23.99)	.002-.005 (.06-.12)
	b	1.9654-1.9661 (49.92-49.94)	.003-.006 (.10-.14)
	c	1.9657-1.9665 (49.93-49.95)	.002-.004 (.06-.09)
	d	2.0244-2.0252 (51.42-51.44)	.002-.004 (.06-.10)
	e	2.0835-2.0842 (52.92-52.94)	.002-.004 (.06-.10)
	f	2.1228-2.1236 (53.92-53.94)	.002-.004 (.06-.10)

VALVE TIMING				
Engine	INTAKE		EXHAUST	
	Open (ATDC)	Close (ABDC)	Open (BBDC)	Close (BTDC)
2746 cc	7°	21°	30°	12°

Ⓢ — Journal diameters vary, with steps from smaller to larger going from front to rear. See Fig. 4. End play is .002-.005" (.050-.128 mm).