

GLC, B2000 & 626 4 CYLINDER

ENGINE CODING

ENGINE IDENTIFICATION

Engine number is located on right front side of engine block.

ENGINE & CYLINDER HEAD

ENGINE

Removal – 1) Remove hood after marking hinge location. Drain cooling system and crankcase. On GLC, remove cooling fan. On all models, remove battery and air cleaner. Disconnect accelerator cable and choke heater wire from carburetor. Disconnect fuel lines at fuel pump and carburetor. On automatic transmission models, disconnect and plug transmission cooler lines at radiator. On all models, remove radiator hose and radiator. Disconnect all engine vacuum hoses.

2) Disconnect wires from temperature sending unit, oil pressure switch, alternator, distributor, back-up light switch and starter. Disconnect exhaust pipe from manifold. On manual transmission models, remove cover plate from clutch housing and clutch release cylinder. On automatic transmission models, remove torque converter and drive plate support bolts. On all models, support transmission with a jack and remove nuts and bolts attaching transmission to engine.

3) Remove starter. On manual transmission models, remove clutch slave cylinder. On all models, remove engine mount attaching nuts and bolts. Install a lifting sling to engine lifting brackets, attach a lifting hoist and raise slightly. Pull engine forward until clear of transmission. Lift engine from vehicle.

Installation – To install, reverse removal procedure.

CYLINDER HEAD

NOTE – Before removal, check timing chain for excessive stretch. To check, readjust the chain tension as explained in **TIMING CHAIN** installation procedure. If gap between slipper head and chain tensioner body exceeds .51" (13 mm), replace the chain.

Removal – 1) Remove engine lifting brackets from cylinder head. Remove exhaust manifold along with port liners and gaskets. Disconnect ignition wires and vacuum lines at distributor. Remove lock nut, then remove distributor from cylinder head.

2) Disconnect hoses and remove air pump with bracket. Remove water pump fan and pulley. Disconnect hose from PCV valve at intake manifold. On manual transmission models, disconnect anti-afterburn valve. On all models, remove attaching bolts, then remove intake manifold and carburetor as an assembly.

3) Remove rocker arm cover, gasket and oil seals. Install ring gear brake tool (49 0118 271A or equivalent) on flywheel to prevent flywheel from rotating. Remove lock nut and washer, then slide distributor drive gear from camshaft. Remove camshaft sprocket lock nut. Remove cylinder head-to-front cover attaching bolt.

4) Loosen cylinder head bolts gradually, in the reverse order of the tightening sequence, and remove bolts. Remove rocker arm assembly. Carefully pull camshaft to rear and remove from sprocket and cylinder head. Remove camshaft sprocket.

CAUTION – Timing chain should be lifted upwards to prevent chain tensioner slipper head from disengaging and dropping down inside front cover. Installation of chain adjuster guide (49-3953-260 for 1415 cc, 49-0660-260 for 1970 cc engines) through front cover inspection hole prior to sprocket removal will prevent disengagement.

5) Remove camshaft bearings from cylinder head, noting their respective locations. Remove the cylinder head and gasket.

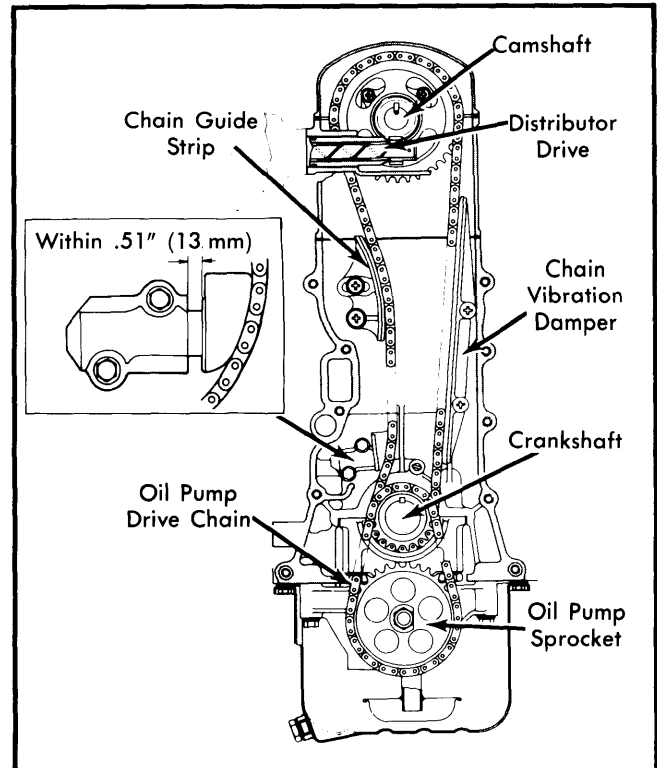

Fig. 1 Engine Cross-Section with Detail of Timing Chain Tensioner

Installation – 1) Install camshaft sprocket in timing chain and position on top of chain guide strip and chain vibration damper, ensuring that matching marks on chain and sprocket are aligned. Install new head gasket. Place cylinder head on aligning dowels.

2) Install camshaft bearings in cylinder head and bearing caps. Lubricate bearings with engine oil. Install camshaft in cylinder head. Install bearing caps. Carefully install camshaft on sprocket while aligning keyway. Position rocker arm assembly on cylinder head.

CAUTION – Ensure that the flat surface of the ball on each rocker arm is facing down.

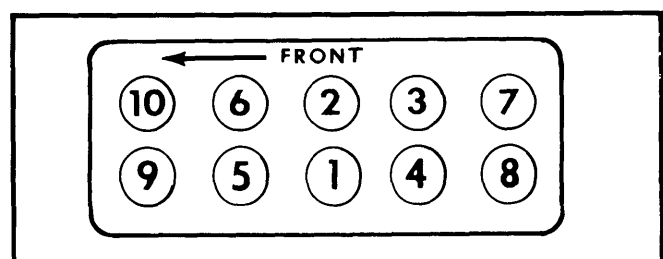

Fig. 2 Tightening Sequence for Cylinder Head

GLC, B2000 & 626 4 CYLINDER (Cont.)

3) Install cylinder head bolts and tighten, in steps, according to sequence shown in Fig. 2. Install cylinder head-to-front cover bolt. Install distributor drive gear, tighten nut and bend lock washer.

4) Adjust timing chain tension by carefully pressing top of chain guide strip, using a lever, through opening of cylinder head. Tighten guide strip attaching screws. Remove chain adjuster guide tool and tensioner will be properly set. Install remaining components in reverse order of removal procedure.

CAMSHAFT

CAMSHAFT

NOTE — Lift timing chain upward to keep the slipper head of chain tensioner from coming out.

Removal — 1) Remove valve cover. Install ring gear brake tool to flywheel. Remove lock nut and washer, slide distributor drive gear from camshaft. Remove lock nut from camshaft sprocket.

2) Remove the bolt that attaches timing chain cover to cylinder head. Remove cylinder head bolts in reverse order of tightening sequence. Lift out rocker arm assembly. Pull camshaft rearward and remove sprocket. Carefully remove camshaft. If necessary, camshaft bearings can be removed at this time.

Installation — To install, reverse removal procedure.

CAMSHAFT BEARING REPLACEMENT

1) Inspect cam face and journals, ensuring that they are not worn or scored. Using a micrometer, measure cam height. Standard cam height for 1415 cc is 1.737" (44.12 mm) for intake and exhaust. Standard cam height for the 1970 cc engine is 1.7731" (45.037 mm) on intake and 1.7718" (45.004 mm) for exhaust cam lobes. Wear in excess of .008" (.20 mm) requires replacement of the camshaft.

2) Measure diameter of camshaft bearing journals. If wear is more than .002" (.051 mm) below minimum standard diameter, camshaft must be ground to accept .010" (.25 mm), .020" (.50 mm) or .030" (.75 mm) undersize bearings.

3) Inspect camshaft bearing clearances using Plastigage method. If standard clearances are exceeded, replace bearings. If new bearings are properly fitted, correct clearance can be obtained without filing, shimming or scraping.

4) Using a dial indicator, check camshaft out-of-round. Camshaft must not exceed .0012" (.030 mm) out-of-round.

5) Check camshaft end play using a feeler gauge. Standard clearance is .001-.007" (.025-.178 mm). If wear limit of .008" (.20 mm) is exceeded, replace the thrust plate.

TIMING CHAIN

Removal — 1) Remove cylinder head and oil pan with engine removed from vehicle. Remove front cover and gaskets, then remove oil thrower from crankshaft. Remove chain tensioner, guide strip and vibration damper.

2) Remove oil pump sprocket lock nut and washer. Remove crankshaft spacer, timing chain and crankshaft sprocket. Remove key and spacer from crankshaft.

Installation — 1) On 1415 cc engines, install timing chain guide strip but do not tighten attaching screws. Install timing

chain vibration damper. On all engines, install spacer and key onto crankshaft. Place timing chain on crankshaft and camshaft sprockets with index marks aligned.

2) Align crankshaft and its sprocket keyway, then fit sprocket onto crankshaft. Install crankshaft spacer. Fit key on oil pump shaft. Install oil pump drive chain onto oil pump and crankshaft sprockets, align keyway and install assembly onto crankshaft and oil pump shafts. On 1415 cc models, install chain adjuster guide (49-3953-260) on adjuster. Install adjuster on cylinder block.

3) On 1415 cc engines, tighten oil pump sprocket nut and bend lock washer tab. Install oil baffle plate and spacer onto crankshaft. On all engines, check oil pump drive chain slack. Chain slack should not exceed .157" (4 mm). Excessive slack on 1970 cc engines can be reduced by installing adjusting shims between cylinder block and oil pump body. On 1415 cc engines, chain must be replaced. Tighten oil pump sprocket nut and bend lock washer tab.

4) On 1970 cc engines, install chain adjuster guide (49-0660-260) on adjuster with spring completely compressed. Install adjuster and chain vibration damper on cylinder block. Install chain guide strip but do not tighten screws. On all engines, adjust timing chain by slightly rotating engine in direction of engine revolution. Press top of chain guide strip with a lever through opening in top of cylinder head and tighten guide strip attaching screws with a screwdriver. Remove chain adjuster guide.

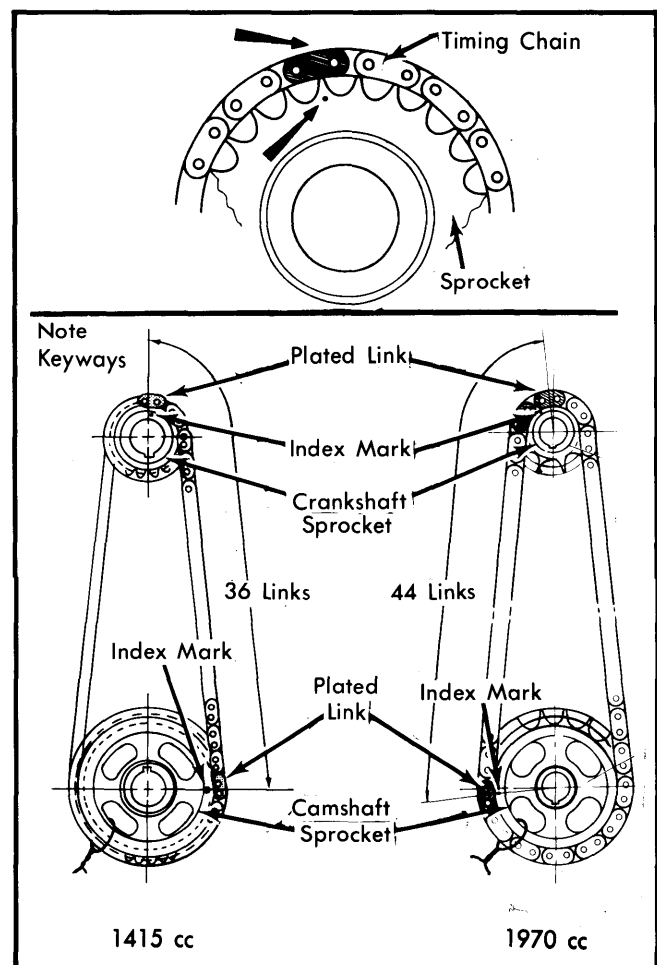

Fig. 3 Alignment Marks of Timing Chain & Sprockets

GLC, B2000 & 626 4 CYLINDER (Cont.)

VALVES

VALVE ARRANGEMENT

Right Side - All Intake
Left Side - All Exhaust

VALVE GUIDE SERVICING

Remove worn valve guide, using valve guide removal/installation tool (49-0221-251A) and hammer. Drive new guide in until ring of guide just touches cylinder head. Install new valve seal on valve guide using a seal pusher tool (49-0223-160D or equivalent).

NOTE - The valve keepers for intake and exhaust valves are not interchangeable. Care must be taken to keep them properly identified.

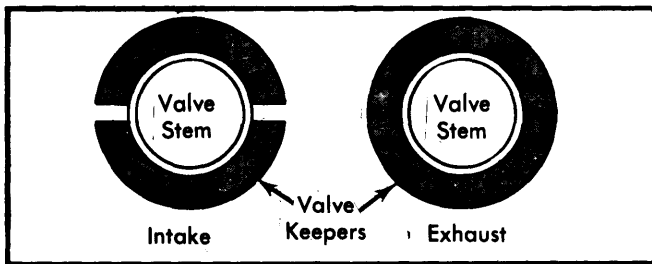

Fig. 4 Intake & Exhaust Valve Keeper Difference

VALVE SPRINGS

1) Remove all carbon from inside of combustion chamber. Using a suitable valve spring compressor, collapse springs and remove stem keepers, retainers, valve springs and seats. Valves can now be removed.

2) With valve springs removed, inspect for corrosion or obvious damage. Use a valve spring tester to determine valve spring condition under a load. Measure valve spring free length and compare findings with specifications.

ROCKER ARM ASSEMBLY

1) With rocker arm assembly removed and disassembled, inspect all components for wear or damage. The standard clearance between rocker arm bore and shaft on 1415 cc is .0008-.0029" (.020-.074 mm) and on 1970 cc is .0011-.0032" (.027-.081 mm). If measured clearance is more than .004" (.010 mm), replace rocker arm or shaft.

2) Reassemble and install rocker shaft while noting the following: Intake and rocker arm supports are interchangeable. Intake side uses 2 rocker shafts. On intake side, end of shaft with longer distance between oil hole and shaft end face each other. Center bearing cap oil hole faces toward intake side.

3) When installing the oil distribution pipe, make sure the oil holes face camshaft. After pipe is installed, press "O" ring into hole for pipe on center bearing cap. When installing rocker

arm assembly, make sure flat surface on ball of each rocker arm faces downward. Align dowels and install assembly on cylinder head. Before tightening cylinder head bolts, offset each of the rocker arms .040" (1 mm) from valve stem center by shifting the rocker shaft support stands slightly.

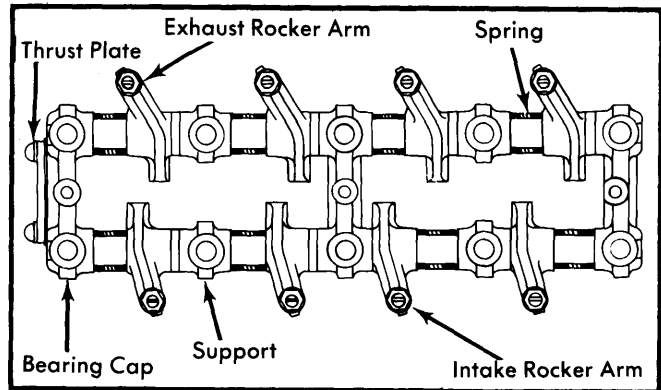

Fig. 5 1415 cc Rocker Arm Assembly

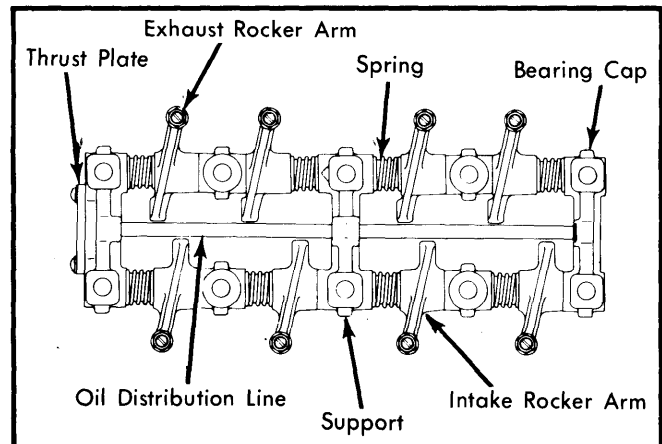

Fig. 6 1970 cc Rocker Arm Assembly

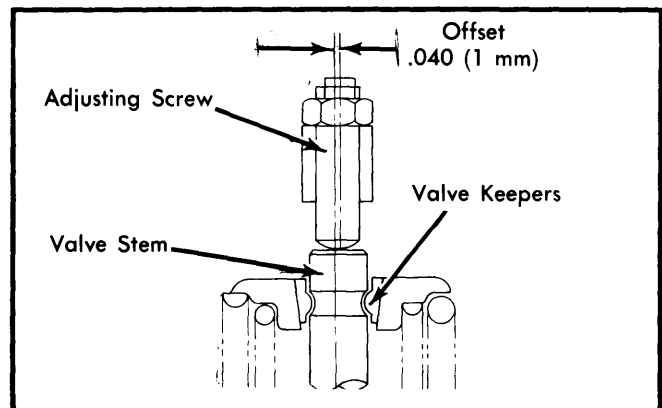

Fig. 7 Rocker Arm Offset

VALVE CLEARANCE

With engine warmed to operating temperature, having torqued the cylinder head bolts to specifications, adjust valves.

GLC, B2000 & 626 4 CYLINDER (Cont.)

Loosen lock nut and insert feeler gauge between rocker and valve stem. Turn adjusting screw until proper clearance is obtained.

NOTE — Before adjusting, ensure flat surface of ball on rocker arm is facing downward.

Valve Clearance Specifications

Application	Intake In.(mm)	Exhaust In.(mm)
1415 cc		
Valve side010 (.25)	.012 (.30)
Cam side007 (.18)	.009 (.22)
1970 cc		
Valve side012 (.30)	.012 (.30)
Cam side009 (.22)	.009 (.22)

PISTONS, PINS & RINGS

PISTON & ROD ASSEMBLY

Removal — Remove oil pan, cylinder head, and oil pump. Make sure connecting rods are marked so they are replaced in their original positions, then remove rod caps. Push piston and rod assembly out of top of cylinder. Take care not to damage bearing journal.

Installation — Oil piston rings, pistons, and cylinder walls with engine oil. Place piston rings approximately 120 degrees apart, so gap is not on thrust side or piston pin side. Install a ring compressor onto piston without disturbing position of rings.

Install piston and rod assembly into its original bore. Make sure "F" mark of piston is facing front of engine. Install rod caps and tighten rod bolts. Install oil pump, oil pan, and cylinder head.

FITTING PISTONS

1) Cylinder bore can be measured using a cylinder gauge. Measurement must be taken at 3 depths and 2 angles as shown in Fig. 8. Difference between maximum and minimum values is actual wear. If cylinder bore wear is .006 (.15 mm) or more, all cylinders must be honed or rebored. If cylinder is honed or rebored, oversized pistons and rings are available in .010" (.25 mm), .020" (.50 mm), .030" (.75 mm) and .040" (1.00 mm) oversizes.

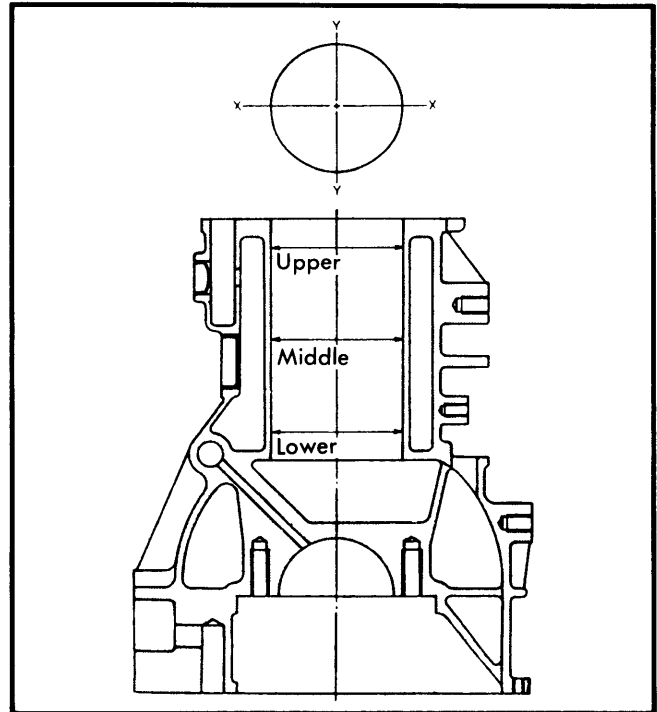

Fig. 8 Points for Measuring Cylinder Bore

2) Carefully inspect pistons and replace those severely damaged due to scoring, scratching or burning. Measure pistons at points A, B and C as shown in Fig. 9, using a micrometer. If piston is not within specifications, replace piston and rebore cylinder.

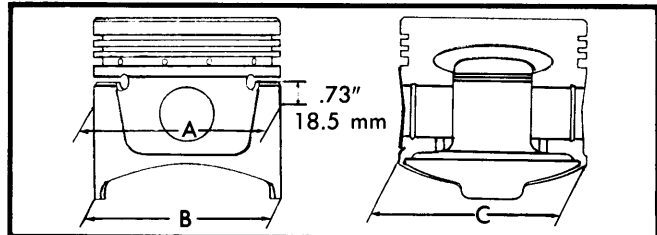

Fig. 9 Points for Measuring Piston

Standard Piston Specifications	
Application	Diameter In. (mm)
1415 ccⓄ	
A	3.0291-3.0299 (76.939-76.959)
1970 cc	
A	3.1474-3.1482 (79.944-79.964)
B	3.1489 (79.980)
C	3.1319 (79.550)
Ⓞ — "B" and "C" diameters not available.	

PISTON PIN REPLACEMENT

1) Piston pin is press fit in connecting rod. Use special tool set (49 8134 040 or equivalent) for removal and installation. For installation, a press load of 1102-3307 lbs. (500-1500 kg) is required. If the press load is not within the load range, replace the pin or connecting rod. Ensure that the piston pin offset is correct. The connecting rod big end oil hole and "F" mark on piston should correspond.

CRANKSHAFT MAIN & CONNECTING ROD BEARINGS

MAIN & CONNECTING ROD BEARINGS

Removal — Remove engine and oil pan. Remove rod and main bearing caps. Check rod and main bearing clearances using Plastigage method. If measured value exceeds correct clearance, bearings must be replaced.

GLC, B2000 & 626 4 CYLINDER (Cont.)

Inspection — 1) Using a micrometer, measure diameter of connecting rod and main journals. If wear is more than .002" (.051 mm) at any journal, crankshaft must be ground to fit .010" (.25 mm), .020" (.50 mm) or .030" (.75 mm) undersize bearings.

2) Using a dial indicator, check crankshaft for out-of-round. Maximum allowable out-of-round is .0012" (.030 mm).

Installation — 1) Fit 5 upper main bearings to cylinder block with oil grooved surface facing crankshaft thrust side. Fit new oil seal at rear of crankshaft. Insert side seals on both sides of rear bearing cap. Install main bearing caps. No. 1 through No. 4 bearing caps are marked for correct installation. No. 5 may or may not be indexed.

2) Insert connecting rod assembly into cylinder as previously described. Fit upper bearing to rod and over crankshaft. Fit lower bearing to rod cap and install cap. Tighten all bolts to specifications.

NOTE — Ensure engine is free to turn.

3) End play is compensated for by thrust washers placed at No. 5 main bearing. Check crankshaft end play using a dial indicator. End play must not exceed .012" (.305 mm). If specification is exceeded, thrust washers must be replaced. Thrust washers are available in .010" (.25 mm), .020" (.50 mm) and .030" (.75 mm) oversizes.

4) Compress camshaft tensioner slipper fully into tensioner body. Install tool (49 1975 260 for 1415 cc and 49 0660 260 for 1970 cc engines) to retain slipper and install tensioner assembly to cylinder block. On 1970 cc engines, install chain vibration damper and tighten screws. Install chain guide strip, but do not tighten screws at this time. Install oil deflector and seal in front cover. Install oil thrower on crankshaft with the edge facing forward.

5) On all engines, fill oil seal lip with grease and install front cover. Install oil pan and gasket. Position camshaft sprocket and chain on top of the chain guide strip and chain vibration damper. Install gasket and cylinder head on block.

NOTE — Ensure matching marks of chain and sprockets are aligned.

6) Install camshaft and bearings in cylinder head. Install rocker arm assembly. Position rocker arms .040" (1 mm) off center of valve stems and tighten cylinder head bolts. Turn crankshaft slightly in the direction of rotation. Press top of chain guide strip with a lever through opening in cylinder head, then tighten guide attaching screws through holes in front cover. Remove tool from tensioner and tension will be properly set. Install remaining components in reverse order of removal procedure.

ENGINE OILING

ENGINE OILING SYSTEM

Oil is circulated by a rotor-type pump. The pump is mounted inside the oil pan and is driven by the crankshaft.

Crankcase Capacity — 3.2 qts. for 1415 cc engines and 4.1 qts. for 1970 cc engines.

Oil Pressure — 50-64 psi (3.5-4.5 kg/cm²) at 3000 RPM.

Oil Filter — Full flow cartridge.

Pressure Regulator Valve — Non-adjustable

OIL PUMP

1) Check clearance between lobes of rotor with a feeler gauge. If clearance exceeds .010" (.25 mm), replace both rotors.

2) Inspect clearance between outer rotor and pump body, using a feeler gauge. Maximum clearance is .012" (.30 mm)

3) To check rotor ends, place a straightedge across pump body and measure clearance rotor and straightedge, using a feeler gauge. Then place straightedge across cover and measure clearance between straightedge and cover.

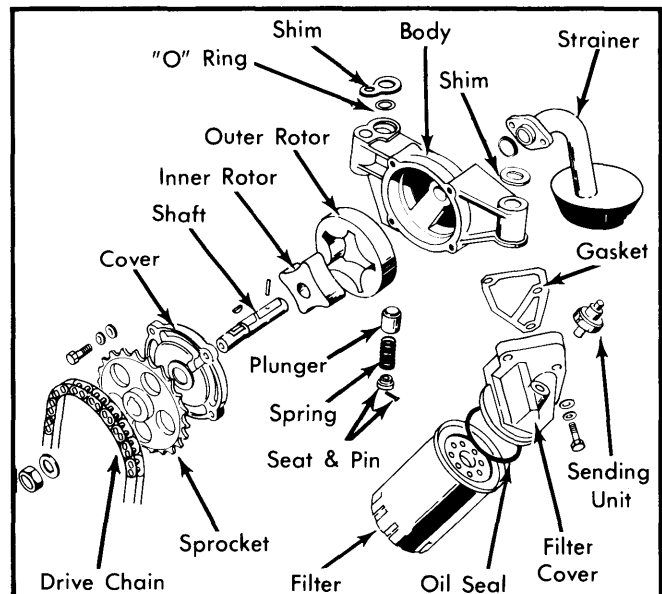

Fig. 10 1970 cc Oil Pump Assembly

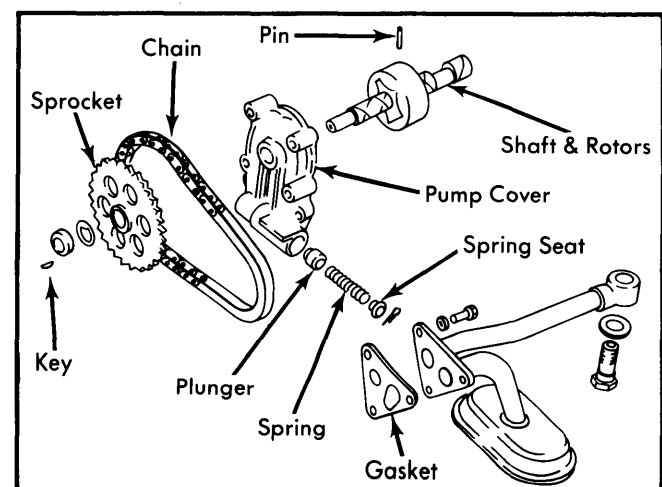

Fig. 11 1415 cc Oil Pump Assembly

Mazda Engines

GLC, B2000 & 626 4 CYLINDER (Cont.)

Oil Pump Specifications

Application	Clearance In. (mm)
Rotor-to-Rotor002-.006 (.051-.052)
Rotor-to-Body006-.010 (.152-.254)
End play002-.004 (.051-.102)

Removal - Remove bolts mounting fan and pulley to water pump. Remove nuts and bolts holding water pump to timing chain cover. Remove alternator bracket and water pump.

Installation - Using a new gasket, install by reversing removal procedure.

Cooling System Capacity - 5.8 qts. for 1415 cc engines and 7.6 qts. for 1970 cc engines.

Thermostat - Begins to open at 190°F. (88°C) and is fully open at 212°F (100°C) for 1415 cc and begins to open 180°F (82°C) and is fully open at 203°F (95°C) for 1970 cc engines.

ENGINE COOLING

WATER PUMP

NOTE - It may be necessary to remove radiator to facilitate water pump removal.

Radiator Cap - 13 psi

ENGINE SPECIFICATIONS

GENERAL SPECIFICATIONS										
Year	Displ.		Carburetor	HP at RPM	Torque (Ft. Lbs. at RPM)	Compr. Ratio	Bore		Stroke	
	cu. ins.	cc					in.	mm	in.	mm
1980										
GLC	86.4	415	1x2 Bbl	9.0:1	3.03	77	2.99	76
B2000	120.2	1970	1x2 Bbl	8.6:1	3.15	80	3.86	98
626	120.2	1970	1x2 Bbl	8.6:1	3.15	80	3.86	98

VALVES							
Engine & Valve	Head Diam. ① In. (mm)	Face Angle	Seat Angle	Seat Width In. (mm)	Stem Diameter In. (mm)	Stem Clearance In. (mm)	Valve Lift In. (mm)
1415 cc							
Intake	1.4173 (35.99)	45°	45°	.055 (1.4)	.3162-.3168 (8.03-8.05)	.0007-.0021 (.018-.053)
Exhaust	1.2205 (31.00)	45°	45°	.055 (1.4)	.3160-.3168 (8.025-8.05)	.0007-.0023 (.018-.058)
1970 cc							
Intake	1.6536 (42.00)	45°	45°	.055 (1.4)	.3162-.3168 (8.03-8.05)	.0007-.0021 (.018-.053)
Exhaust	1.2992 (32.99)	45°	45°	.055 (1.4)	.3160-.3168 (8.025-8.05)	.0007-.0023 (.018-.058)

① - Specification is ±.0039" (.01 mm).

PISTONS, PINS, RINGS						
Engine	PISTONS		PINS		RINGS	
	Clearance In. (mm)	Piston Fit In. (mm)	Rod Fit In. (mm)	Rings	End Gap In. (mm)	Side Clearance In. (mm)
1415 cc & 1970 cc	①.0021-.0026 (.054-.067)	②0-.0009 (0-.024)	No. 1 No. 2 Oil	.008-.016 (.20-.41) .008-.016 (.20-.41) .012-.035 (.31-.89)	③.0012-.0025 (.030-.064) ④.0012-.0025 (.030-.064)

① - 1970 cc should be .0014-.0030" (.036-.075 mm).

② - Interference fit.

③ - 1970 cc should be .0012-.0028" (.030-.070 mm).

④ - 1970 cc should be .0012-.0025" (.030-.065 mm).

Mazda Engines

GLC, B2000 & 626 4 CYLINDER (Cont.)

ENGINE SPECIFICATIONS (Cont.)

CRANKSHAFT MAIN & CONNECTING ROD BEARINGS In. (mm)							
Engine	MAIN BEARINGS				CONNECTING ROD BEARINGS		
	Journal Diam.	Clearance	Thrust Bearing	Crankshaft End Play	Journal Diam.	Clearance	Side Play
1415 cc	1.9703-1.9709 (50.045-50.065)	.0009-.0017 (.024-.042)	No. 5	.004-.006 (.10-.15)	1.5766-1.5772 (40.045-40.060)	.0009-.0019 (.024-.048)	.004-.008 (.11-.21)
1970 cc	2.4822-2.4828 (63.045-63.060)	.0012-.0020 (.031-.050)	No. 5	.003-.009 (.08-.24)	2.0884-2.0890 (53.045-53.060)	.0011-.0030 (.027-.077)	.004-.008 (.11-.21)

VALVE SPRINGS			
Engine	Free Length In. (mm)	PRESSURE Lbs. @ In. (kg @ mm)	
		Valve Closed	Valve Open
1415 cc	1.449 (36.8)	20.9 @ 1.26 (9.5 @ 32.0)
		43.7 @ 1.319 (19.8 @ 33.5)
1970 cc	1.449 (36.8)	20.9 @ 1.26 (9.5 @ 32.0)
		31.4 @ 1.339 (14.25 @ 34.0)

VALVE TIMING				
Engine	INTAKE		EXHAUST	
	Open (BTDC)	Close (ABDC)	Open (BBDC)	Close (ATDC)
1415 cc	15°	55°	58°	12°
1970 cc	14°	53°	58°	9°
B2000	10°	57°	54°	13°
626				

CAMSHAFT				
Engine	Journal Diam. In. (mm)	Clearance In. (mm)	Lobe Lift In. (mm)	
1415 cc	Front	1.6550-1.6558 (42.035-42.051)	.0014-.0030 (.035-.076)
	Center	1.6562-1.6568 (42.065-42.081)	.0026-.0042 (.065-.106)
	Rear	1.6550-1.6558 (42.035-42.051)	.0014-.0030 (.035-.076)
1970 cc	Front	1.7733-1.7739 (45.040-45.055)	.0007-.0027 (.019-.069)
	Center	1.7737-1.7743 (45.050-45.065)	.0011-.0031 (.029-.079)
	Rear	1.7733-1.7739 (45.040-45.055)	.0007-.0027 (.019-.069)

TIGHTENING SPECIFICATIONS	
Application	Ft. Lbs. (mkg)
1415 cc	
Cylinder Head	
Cold	47-51 (6.5-7.0)
Hot	51-54 (7.0-7.5)
Main Bearing Cap	43-47 (6.0-6.5)
Connecting Rod Cap	22-25 (3.0-3.5)
Oil Pump Sprocket	22-25 (3.0-3.5)
Camshaft Sprocket	51-58 (7.0-8.0)
Crankshaft Pulley	80-87 (11.0-12.0)
Distributor Drive Gear	51-58 (7.0-8.0)
Intake Manifold	14-19 (1.9-2.6)
Exhaust Manifold	14-19 (1.9-2.6)
1970 cc	
Cylinder Head	
Cold	59-64 (8.2-8.8)
Hot	69-72 (9.5-10.0)
Main Bearing Cap	61-65 (8.4-9.0)
Connecting Rod Cap	30-33 (4.1-4.6)
Oil Pump Sprocket	22-25 (3.0-3.5)
Camshaft Sprocket	51-58 (7.0-8.0)
Crankshaft Pulley	101-108 (14.0-14.9)
Distributor Drive Gear	51-58 (7.0-8.0)
Intake Manifold	14-19 (1.9-2.6)
Exhaust Manifold	16-21 (2.2-2.9)