

## XJ6 6 CYLINDER

### ENGINE CODING

#### ENGINE IDENTIFICATION

Engine can be identified by the number stamped on top of cylinder block at rear of engine and on identification plate in engine compartment.

### ENGINE & CYLINDER HEAD

#### ENGINE

**NOTE** — Engine and transmission are removed as an assembly.

**Removal** — 1) Remove hood and disconnect battery. Discharge air conditioning system. Disconnect and cap refrigerant lines. Remove fuel lines from fuel cooler and plug fuel inlet line. Remove fuel cooler mounting screws and secure cooler, receiver-drier, refrigerant lines and fuel lines away from engine.

2) Remove fender brace rods. Remove air cleaner. Detach and remove radiator. Disconnect coolant hoses to expansion tank. Remove both engine mount-to-bracket nuts. Drain power steering fluid. Disconnect power steering lines. Slacken pump mounting bolts and push pump as close as possible to engine.

3) Pull connectors from alternator. Separate connector plug from engine harness. Disconnect brake vacuum pipe at manifold, and secure pipe out of way. Release pipe clip and pull heater-A/C operating vacuum pipe from non-return valves; secure away from engine. Remove exhaust manifolds.

4) Remove starter cable and solenoid cable. Disconnect heater hoses at firewall connectors. From fuel injection system, disconnect the following: Thermo-time switch, cold start injector, throttle switch, oxygen sensor, auxiliary air valve, water temperature sensor and throttle linkage. Disconnect hoses from charcoal canister.

5) Position suitable lifting device and attach to rear lifting eye on engine. Remove nut at center of rear transmission mounting. Unscrew nuts securing bracket on transmission. Remove heat shield. Position jack to support mounting plate of transmission and unscrew mounting bolts. Lower jack and remove mounting plate along with spring washers and rubber rings.

6) Remove special nuts securing propeller shaft to output flange. From transmission unit selector lever, remove nut to release ball peg on inner selector cable. Remove setscrew and spring washer securing outer selector cable clamp. Disconnect speedometer cable from transmission.

7) From front of vehicle, position jack to support transmission assembly below oil sump. Support engine on lifting assembly. Lift front of engine while lowering rear and withdraw engine/transmission assembly forward and upward.

**CAUTION** — Use extreme care when withdrawing engine to prevent damage to air conditioning expansion valve.

**Installation** — Fit insulating material across transmission and reverse removal procedure to complete installation. Ensure that all fluid levels are to specifications. Evacuate and charge air conditioning system.

#### CYLINDER HEAD

**Removal** — 1) Disconnect battery and drain cooling system. Remove both wing valance stays (firewall-to-fender support rods), removing pressure line from support rod. Remove air cleaner. Detach throttle linkage and disconnect thermo-time switch, cold start injector, throttle switch, oxygen sensor, auxiliary air valve and water temperature sensor.

2) Disconnect and plug fuel lines at fuel cooler (heat exchanger) and move cooler to side of engine compartment. Remove heat shield from exhaust manifold. Remove steering pump drive belt and swing pump away from engine. Remove top radiator hose and pull remote header and radiator bleed lines from header tank. Disconnect coolant hose from water pump.

3) Disconnect any remaining lines or wires from intake manifold, noting position for assembly. Detach exhaust manifolds from head. Remove distributor cap, spark plugs and plug wires. Disconnect 2 camshaft oil lines from rear of head and remove camshaft covers. Detach breather housing from front of head.

4) Remove camshaft sprocket retaining bolts from both camshafts and slide sprockets up support brackets. Mark aligning holes in adjuster plates. Working from center outward, remove cylinder head bolts. Carefully lift cylinder head assembly from engine.

**CAUTION** — Crankshaft must NOT be rotated after camshaft sprockets are disconnected and head is still in place. When head is removed, it must not rest on a flat surface. Support head with wooden blocks at each end to protect open valves which protrude.

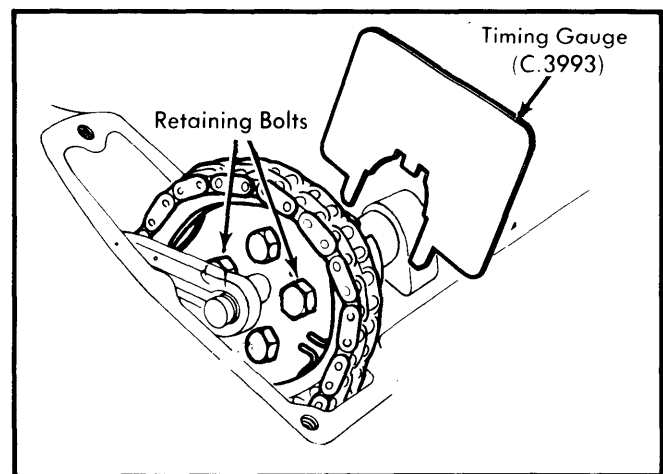

**Fig. 1** Retaining Bolts Installed to Hold Camshaft During Cylinder Head Installation

**Installation** — 1) Install new head gasket (ensuring "TOP" mark is upward). Rotate crankshaft until No. 6 cylinder (front) is at TDC, with rotor pointing approximately forward along engine.

2) Rotate camshafts until suitable timing gauge (C.3993) can be located in front flange slots. See Fig. 1. Lower cylinder head into position, attach spark plug wire brackets and lifting brackets to appropriate head studs, then place washers and

## XJ6 6 CYLINDER (Cont.)

14 large domed nuts on stud. Affix nuts and washers at forward end of head, then tighten all nuts. See Fig. 2.

3) Locate sprockets on camshaft flanges and ensure both holes in each flange are positioned with aligning holes marked during removal. If necessary, remove circlip and reposition adjuster plate. Make sure engine is not rotated until camshaft sprockets are fully seated and chain installed.

4) Secure each adjuster plate to camshaft, then rotate engine until remaining attachment holes are accessible. Install bolts and bend up lock plate tabs. Set timing chain tension using a suitable adjusting tool (JD2B). Tighten lock nut.

5) Ensure No. 6 (front) cylinder is at TDC and recheck position of camshafts using timing gauge (C.3993). Complete installation by reversing remainder of removal procedures. Recheck ignition timing and perform exhaust emission check.

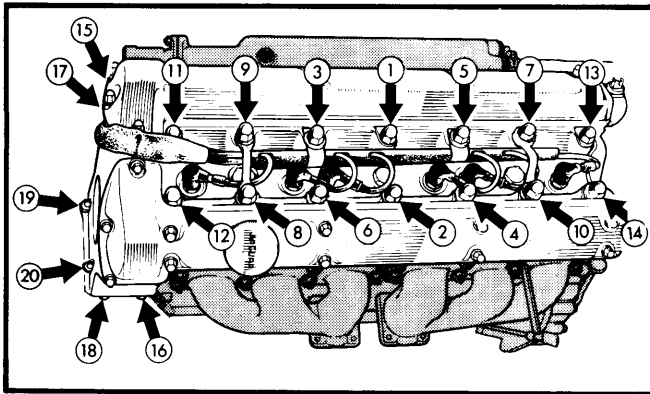

Fig. 2 Jaguar XJ6 Cylinder Head Tightening Sequence

## CAMSHAFTS

### CAMSHAFTS

**Removal** – 1) Remove camshaft covers and detach breather housing from front of head. Using suitable tool (JD.2B), slacken timing chain by rotating tool clockwise. Remove camshaft sprocket retaining bolts from each sprocket, rotating crankshaft as necessary to gain access to remaining bolts.

2) Rotate crankshaft further until timing gauge (C.3993) can be installed. Draw sprockets off camshaft and slide up support brackets. Mark attachment holes in adjuster plate for assembly reference. Remove camshaft bearing caps and withdraw camshaft.

**CAUTION** – Crankshaft **MUST NOT** be rotated after camshaft sprockets are removed.

**Installation** – To install, reverse removal procedure, ensuring that all components are replaced in original position.

**NOTE** – If preceding instructions have not been followed, it will be necessary to ensure that valve timing is still correct. See Valve Timing.

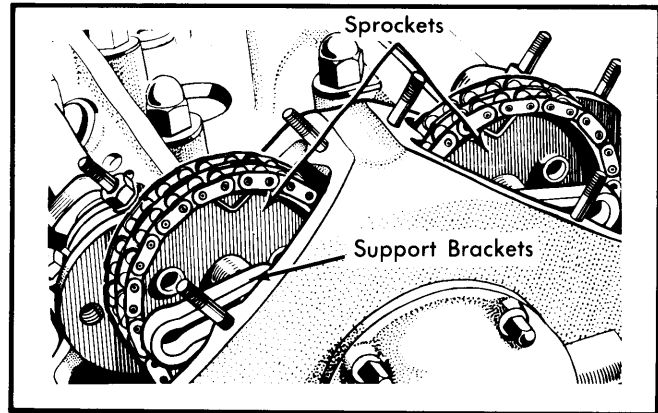

Fig. 3 Camshaft Sprockets in Disconnected Position

## ENGINE FRONT COVER & OIL SEAL

**Removal** – 1) Remove radiator and fan belt. Mark position of vibration damper for reassembly. Remove pulley. Using a pair of levers, pry damper off of split cone. Remove split cone from crankshaft.

2) Remove oil pan and water pump. Unscrew screws attaching timing cover and slide timing cover and oil seal off of crankshaft.

**Installation** – 1) Place new seal in groove in timing cover. Using a new gasket and sealing compound, install timing cover and seal. Reinstall oil pan with a new gasket. Install short screw in front right hand corner of oil pan.

2) Reinstall split cone on crankshaft. Position crankshaft damper to mark, install pulley and torque attaching bolts to specifications. Reinstall remaining components in reverse of removal procedures.

## VALVE TIMING

1) Rotate engine so that No. 6 (front) piston is at TDC on compression stroke and distributor rotor arm points to No. 6 segment. Check that timing chains are properly adjusted. See *Timing Chain Replacement*.

2) Remove lock wire from camshaft sprocket screws. Rotate crankshaft until inaccessible screws can be removed. Return engine to TDC of No. 6 piston and remove retaining screws. Tap camshaft sprockets off camshaft flanges.

3) Position camshafts accurately with valve timing gauge, and check that TDC marks are in exact alignment. See Fig. 7. Withdraw clips from camshaft sprockets and press adjusting plates forward until serrations disengage. See Fig. 4.

4) Replace sprockets on flanges of camshaft and align two holes in adjuster plate with holes in flanges. Engage serrations of adjuster plates with serrations in sprocket.

**NOTE** – Screw holes must be in exact alignment. If difficulty is experienced in aligning holes turn adjuster plates 180° and realign holes.

5) Replace circlips in camshaft sprockets. Replace camshaft sprocket screws and lock wire. Recheck valve timing.

## XJ6 6 CYLINDER (Cont.)

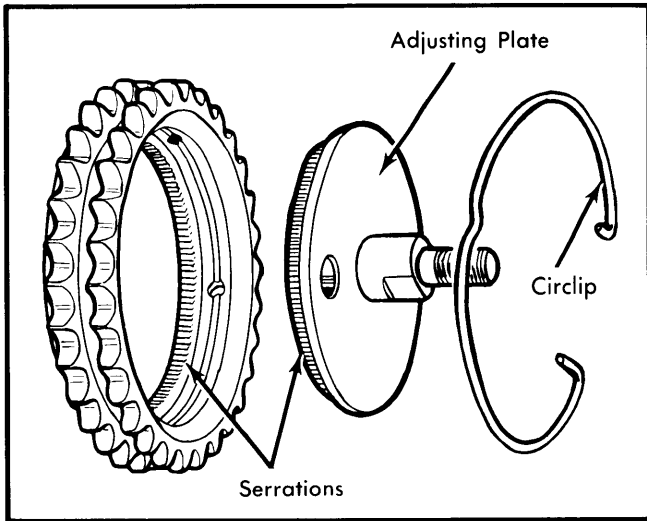

**Fig. 4 Expanded View of Camshaft Sprocket Assembly**

### VALVES

#### VALVE ARRANGEMENT

**Left Side** – All exhaust.  
**Right Side** – All intake.

#### VALVE GUIDE SERVICING

Check valve guide for wear and proper guide-to-valve stem clearance. If guide is worn beyond specifications, replace guide by heating head in boiling water for approximately 30 minutes (or by other suitable method), then drive guide(s) out of head from combustion chamber end. Coat new guide with graphite grease and refit circlip. Reheat head and drive new guide in from top until circlip is seated in groove.

**NOTE** – When installing oversize replacement guides, check O.D. of guide to be used. If necessary, ream cylinder head bore to obtain proper interference fit.

#### Replacement Valve Guides

Application	Size Mark	Dimension In. (mm)
Standard	No Mark	.501-.502 (12.73-12.75)
1st Oversize	1 Groove	.503-.504 (12.78-12.80)
2nd Oversize	2 Grooves	.506-.507 (12.85-12.87)
3rd Oversize	3 Grooves	.511-.512 (12.98-13.00)

#### VALVE SPRING SERVICING

**CAUTION** – Support ends of cylinder head with wooden blocks to prevent damage to valves. Opened valves protrude below face of cylinder head.

1) Remove camshaft bearing caps, note markings for reassembly. Remove camshaft, tappets and adjusting pads. Retain tappets and pads in proper order for reassembly.

2) Install suitable spring compressor (Churchill No. JD.6118C) and a block of wood between valve and work table. Compress springs and remove valve keepers. Compare old spring with new spring or with specification table. Replace springs as necessary. To install, reverse procedure.

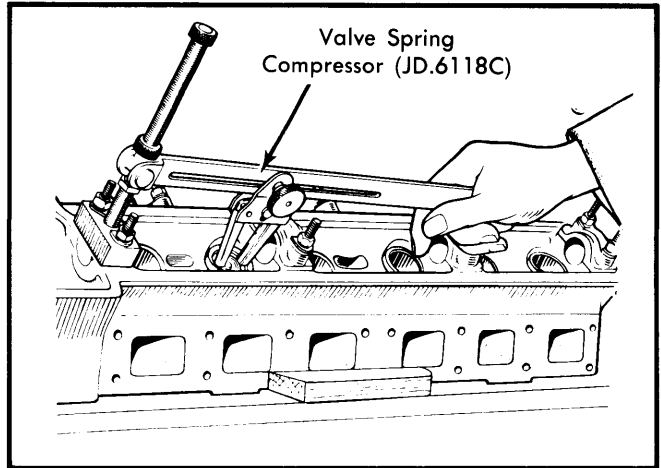

**Fig. 5 Valve Spring Compressor Tool Installation**

#### VALVE TAPPET SERVICE

**NOTE** – Valves and operating mechanisms are numbered and must be kept in order when disassembled. No. 1 is at flywheel end of engine.

1) Remove tappets and adjusting pads and inspect guides, tappets and pads for wear. If tappet guide is to be replaced, bore out old guide until it collapses, using care not to damage head bore. Ensure head is at room temperature and measure head bore of tappet guide.

2) Grind replacement guide to obtain a .003" (.076 mm) interference fit in head. Grind same amount from "lead-in" at bottom end of guide. Heat head and install tappet guide, ensuring that lip at top guide seats evenly in head recess. Allow to cool and ream guide bore to 1.375" (34.93 mm). Replace other parts as necessary.

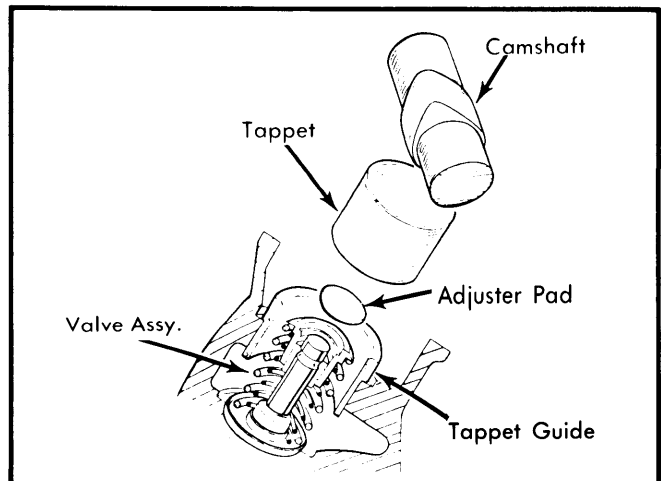

**Fig. 6 Valve Tappet and Guide Assembly**

## XJ6 6 CYLINDER (Cont.)

### VALVE TAPPET CLEARANCE

**NOTE** — If checking valve clearances with cylinder head removed, the camshafts must be installed and checked one at a time. It is imperative that this be followed, as position fouling is likely if camshafts are rotated independently while both are installed.

1) If not already done, remove camshaft covers. Rotate camshaft and record clearance between heel of each cam and its respective tappet. If head is installed, and adjustment is to be made, rotate camshaft and install valve timing gauge (C.3993) before removing final camshaft retaining bolt. If required, disconnect sprockets from camshafts. See *Valve Timing*.

2) Remove camshaft bearing caps and lift off camshaft. Remove each tappet that requires adjustment and note its location for assembly in original position. Remove adjusting pad and measure thickness.

3) Use measured pad thickness and difference between measured valve clearance and specified clearance to calculate required thickness of new adjusting pad. Adjusting pads are available in increments of .001" (.03 mm) from .085" (2.16 mm) to .110" (2.79 mm) and are marked with letters from "A" to "Z" respectively.

4) Insert correct adjusting pads and install tappets. Attach camshafts (using timing gauge). Torque camshaft bearing cap nuts to 9 ft. lbs. (1.2 mkg), connect camshaft sprockets, and install camshaft covers.

### PISTONS, PINS & RINGS

#### OIL PAN

**NOTE** — Oil pan removal is best accomplished with engine out of vehicle. Following procedures may be used with engine installed.

**Removal & Installation** — Remove front suspension components to gain access and suitable clearance. Drain engine oil. Remove oil return pipe nuts and transmission oil cooler line clips. Remove screws and nuts holding pan to engine and remove pan. To install, ensure that all mating surfaces are clean. Lightly grease seals and gaskets and install pan. Reverse removal procedure to complete installation.

**NOTE** — Do NOT trim seal ends. Press into groove until flush. Oil return pipe must have new "O" ring and fit in sump properly. Ensure that short screw is replaced in right front corner of pan.

#### PISTON & ROD ASSEMBLY

**NOTE** — Piston/connecting rod assemblies are numbered to their corresponding position in engine. No. 1 cylinder is at rear of engine.

**Removal** — With cylinder head and oil pan (sump) removed, unscrew nuts from connecting rods and remove bearing caps. Remove bolts from connecting rods and push piston/rod assembly out top of cylinder.

**Installation** — Use suitable ring compressor and insert piston/rod assembly so that "FRONT" stamp on piston is toward front of engine. If installing new parts, stamp-mark with numbers "1" through "6" corresponding to the bore in

which they are installed. Liberally coat bearing shells and journals with oil and complete installation in reverse order of removal.

#### PISTON RINGS

After checking ring end gap and side play, install compression rings in top two grooves and oil ring in bottom groove. Both compression rings have tapered peripheries and are marked with "TOP" to ensure correct installation. The top ring is also chrome-plated and carchaph (red) coated; the red coating must NOT be removed. When fitting oil ring, ensure expander ends do not overlap.

#### PISTON PINS

When removing and replacing piston pins, immerse assembly in hot oil bath (or use other suitable method) to bring piston end of assembly to approximately 230°F (110°C). When installing pins, always use new pin circlips. Note that pins are color coded for grading purposes. Always select proper color pin for replacement.

#### FITTING PISTONS

Check piston and cylinder bore to determine if proper clearance exists. If necessary to rebore cylinder for installation of oversize piston, note that reboring is not to exceed .030" (.76 mm). Oversize pistons are available in .010", .020", and .030" (.25 mm, .51 mm, and .76 mm) oversizes. If replacing pistons with standard sizes (no reboring), note the following list of piston grades and select replacement piston of same grade. Piston grade is stamped in piston crown and on top face of block adjacent to cylinder.

#### Standard Piston Grading

Stamp Mark	Cylinder Diameter In. (mm)
F .....	3.6250-3.6253 (92.075-92.083)
G .....	3.6254-3.6257 (92.085-92.093)
H .....	3.6258-3.6261 (92.095-92.103)
J .....	3.6262-3.6265 (92.106-92.113)
K .....	3.6266-3.6269 (92.116-92.123)

#### CYLINDER LINERS

1) Should piston-to-cylinder clearance be excessive and reboring requires more than .030" (.76 mm) to clean up cylinders, new cylinder liners must be installed.

2) Press out the worn liners from below, using a suitable block. Lightly coat outer top half of new liner with a jointing compound, then press in new liner until flush with top of block. Smear more jointing compound around area of liner-to-block mating surface.

3) Bore out liner to correspond with grade of piston to be installed. Following reboring process, the blanking plugs in the main oil gallery should be removed and cylinder block oilways

## XJ6 6 CYLINDER (Cont.)

thoroughly cleaned. When dry, coat interior of crankcase with an oil and heat resistant paint.

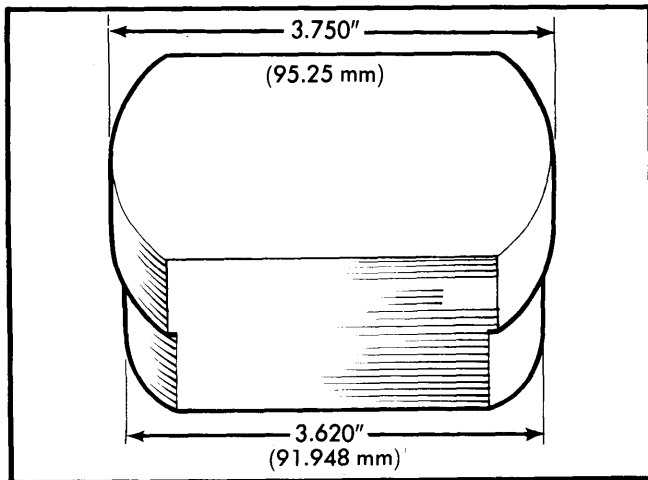

Fig. 7 Cylinder Liner Removing and Installing Block

### CRANKSHAFT MAIN & CONNECTING ROD BEARINGS

#### THRUST BEARING ALIGNMENT

Thrust bearing washers are used on center main bearing caps to adjust endplay. If beyond specifications, bearings .004" (.10 mm) oversize as well as standard are available. Install with white metal side (with groove) outwards.

#### MAIN BEARING SERVICE

Remove connecting rod and main bearing caps, retaining all parts in exact order for reassembly. Note that all caps are numbered for reassembly reference. When wear or out-of-roundness exceeds .003" (.08 mm), regrind crankshaft and install undersize bearings. Bearings are available in .010", .020", .030", and .040" (.25 mm, .51 mm, .76 mm, and 1.02 mm) undersizes. If regrinding must exceed .040" (1.02 mm), replace crankshaft.

#### REAR MAIN BEARING OIL SEAL

**NOTE** — The following procedure must be performed before crankshaft is reinstalled.

1) Carefully tap new rear oil seal halves into position, then roll seal into housing (with a hammer handle) until ends do not protrude. **NOTE** — DO NOT cut seal ends. When both halves are properly in place, secure them with Allen screws.

2) Attach rear main bearing cap without bearings and torque to 72 ft. lbs. (10 mkg). Assemble rear oil seal housing to cylinder block, using three Allen screws. Lightly coat inside surface of oil seal with graphite grease and insert a suitable sizing tool (JD.17B) as shown in illustration. Press tool inward and turn until it is fully seated; this should properly size the oil seal. Remove sizing tool by pulling and twisting in opposite direction. Remove oil seal housing and install crankshaft.

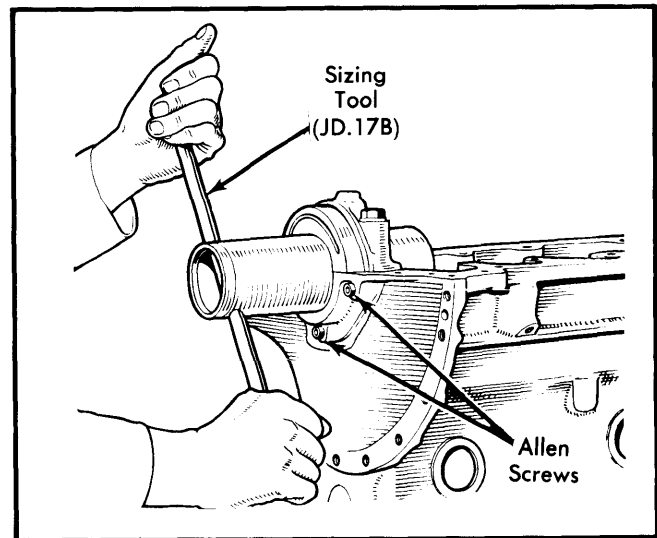

Fig. 8 Sizing Rear Oil Seal

## TIMING CHAIN

### TIMING CHAIN REPLACEMENT

**Removal** — 1) Remove cylinder head, oil pan, water pump, crankcase breather, vibration damper (including cone and Woodruff key), and timing gear cover. Withdraw timing pointer, distance piece, and front oil seal.

2) Remove oil slinger from crankshaft. Unscrew two bottom timing chain tensioner and chain guides retaining screws. Withdraw conical filter behind tensioner. Slacken four setscrews securing top timing chain assembly (do not remove setscrews at this point).

3) Withdraw crankshaft timing sprocket and chain assembly. Be sure to remove spacers, top timing chain damper, and top timing chain retainer. Disengage camshaft sprockets from top chain. Remove nut and serrated washer from idler shaft and withdraw serrated plate, plunger, and spring.

4) Remove nuts retaining front mounting bracket to rear mounting bracket. Remove timing chains from intermediate and idler sprockets. Draw idler shaft, idler sprocket, and bushing from rear mounting bracket. Remove circlip and press intermediate shaft from rear mounting bracket. Note location of bushing and shim under intermediate sprocket.

**Installation** — 1) Position eccentric idler shaft to hole in front mounting bracket. Position spring and plunger in bracket and locate serrated plate on shaft. Loosely secure plate using washer and nut.

2) Attach idler sprocket (21 teeth) to idler shaft. Replace intermediate sprocket (large gear forward) onto intermediate shaft, placing shim in position. Install shaft assembly in rear mounting bracket, ensuring roll pin engages in slot; retain with circlip.

3) Locate top timing chain (longer) on small intermediate sprocket, and lower timing chain on large sprocket. Loop top chain beneath idler sprocket and secure top mounting bracket to rear bracket.

## XJ6 6 CYLINDER (Cont.)

4) Install four long setscrews and spring washers to front mounting bracket and attach dampers, chain support plate, and spacers to setscrews. Equalize loops of top timing chain and locate camshaft sprockets in loops. Rotate eccentric idler shaft to lift idler sprocket to its highest position between camshaft sprockets.

5) Ensure Woodruff key is positioned in crankshaft. Locate crankshaft sprocket, but do not fully seat at this time. Loop bottom timing chain beneath crankshaft sprocket, then tap sprocket until it is fully seated. Position and secure crankshaft sprocket assembly.

6) Install, but do not tighten, bottom timing chain guides. Insert conical filter into its hole in cylinder block. Screw slipper into tensioner until .125" (3.17 mm) exists between slipper and body. Locate tensioner on shims as necessary to ensure slipper runs central on chain, and secure using two setscrews and lock plate.

7) Place slip gauge or spacer card supplied with new tensioner between slipper and body of tensioner to maintain dimension set earlier, then adjust intermediate damper to touch chain. Tighten setscrews and bend up tabs of lock plate. Remove slip gauge and top chain or tensioner slipper to release ratchet. Position oil slinger on crankshaft. Replace timing cover.

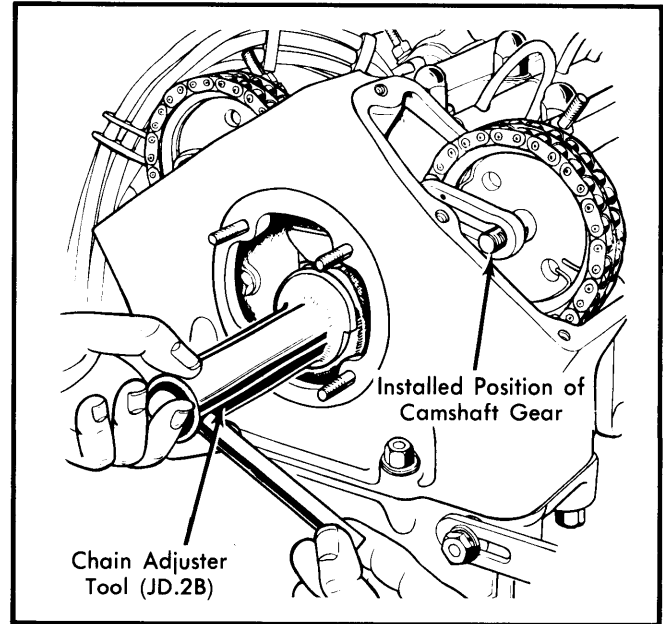

Fig. 10 Adjusting Upper Timing Chain

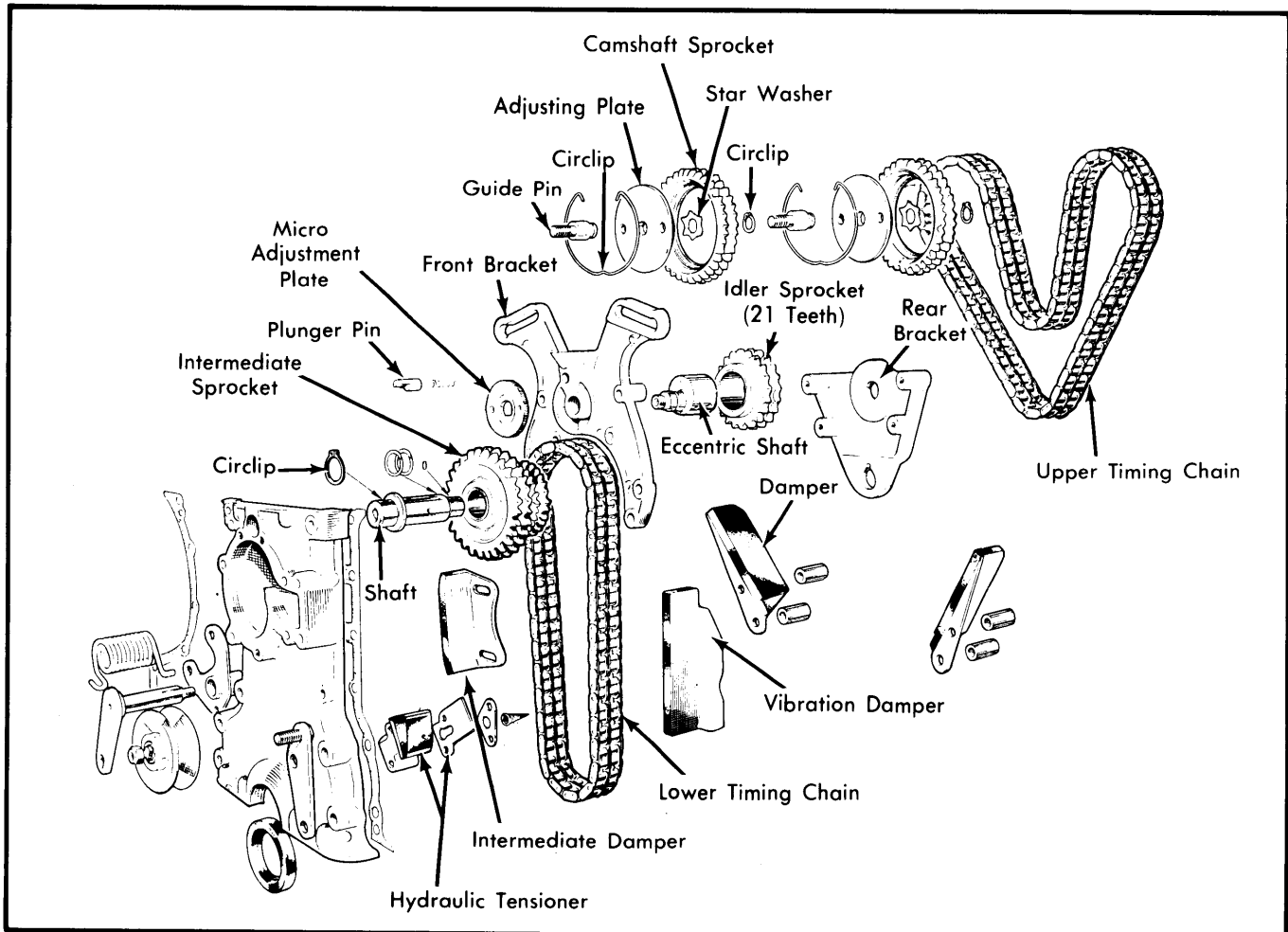

Fig. 9 Exploded View of Timing Gear and Chain Assembly

## XJ6 6 CYLINDER (Cont.)

8) Adjust upper timing chain by loosening locknut on eccentric shaft, then use tool (JD.2B) to rotate eccentric counterclockwise until chain has proper tension. DO NOT use excessive force to tighten chain. Tighten locknut and install remaining components.

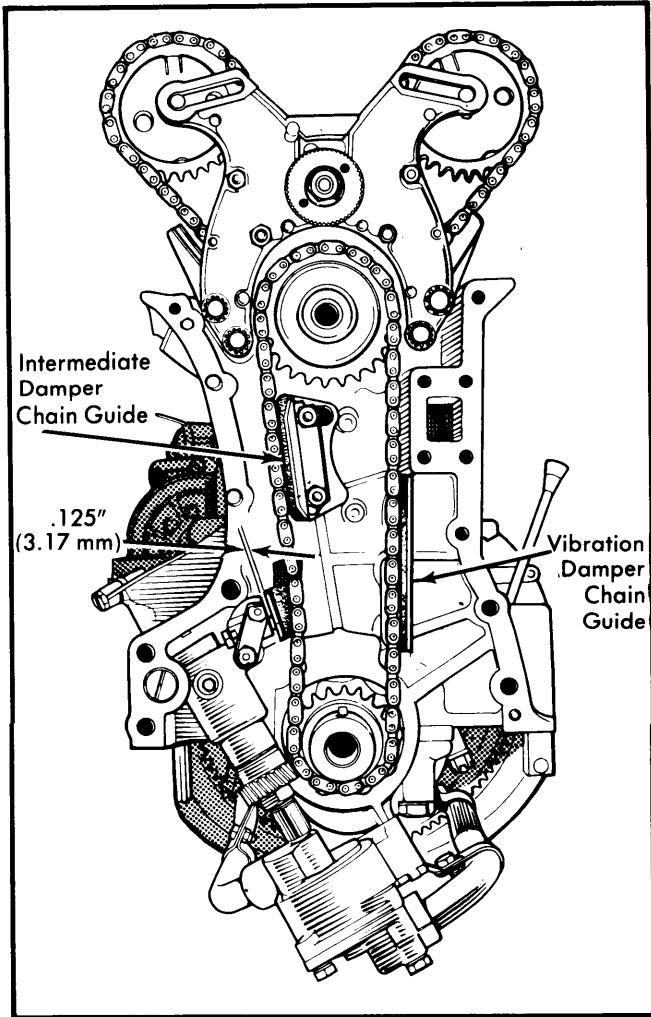

Fig. 11 Lower Timing Chain Adjustment Measuring Point

### ENGINE OILING

#### ENGINE OILING SYSTEM

Lubrication is provided by a gear driven eccentric rotor type pump. Oil from pump goes through a full-flow oil filter to all moving engine components.

**Crankcase Capacity** – 8.7 quarts.

**Oil Filter** – Replace every 3,000 miles.

**Normal Oil Pressure (Hot)** – 40 psi @ 3,000 RPM.

#### OIL PUMP

**Removal** – Remove oil pan, suction and delivery pipes. Remove bolts attaching oil pump to front main bearing cap. Withdraw pump and coupling sleeve at top of drive shaft.

**Disassembly** – 1) Remove bolts and take off bottom cover. Remove inner and outer rotors. Inner rotor is pinned to drive shaft and cannot be disassembled.

2) Check clearances of inner and outer rotor lobes, outer rotor-to-body and rotor-to-cover plate. Place drive shaft in a soft jawed vise and check that rotor is tight on pin.

**NOTE** – Drive shaft, inner and outer rotors are supplied as an assembly only.

**Reassembly** – Reassemble in reverse order of disassembly. Install outer rotor to pump body with chamfered end forward. Use new "O" rings on suction and delivery pipes. To install, reverse removal procedures.

### Oil Pump Specifications

Application	Clearance In. (mm)
Inner-to-Outer Rotor .....	.006 (.15)
Outer Rotor-to-Body .....	.010 (.25)
Rotor-to-Cover (End Play) .....	.0025 (.06)

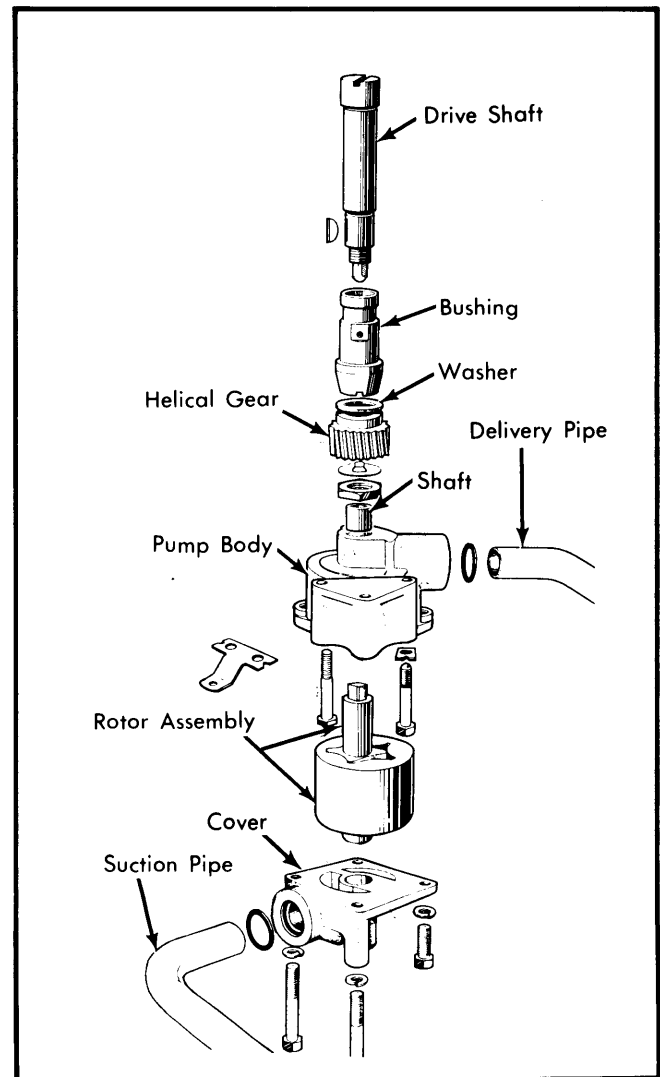

Fig. 12 Exploded View of Jaguar Oil Pump

## XJ6 6 CYLINDER (Cont.)

### ENGINE COOLING

#### WATER PUMP

**Disassembly** – 1) Remove water pump and gasket from timing cover. Pull fan hub from shaft with a puller. Loosen lock nut and remove Allen locating screw.

2) Using an arbor press and a tube measuring 1.094" (27.79 mm) O.D. and .969" (24.60 mm) I.D., press shaft and impeller assembly out of pump body.

3) Press shaft from impeller and remove seal and rubber thrower. Spindle and bearing assembly cannot be further disassembled.

4) Clean and inspect all parts for wear or damage. Bearing is sealed and lubricated, therefore do not wash in solvents.

**Reassembly** – 1) Install shaft and bearing assembly into pump body from rear. Align and install locating screw and lock nut. Place rubber thrower in its groove on shaft in front of seal.

2) Coat outside of brass seal housing with suitable water resistant sealer and install into recess in pump housing. Push seal into its housing with carbon face towards rear of pump.

3) Press impeller onto shaft until rear face of impeller is flush with end of shaft. Press fan hub onto shaft until it is flush with end of shaft.

**Cooling System Capacity** – 19.5 quarts.

### TIGHTENING SPECIFICATIONS

Application	Ft. Lbs. (mkg)
Cylinder Head Nuts .....	54 (7.5)
Main Bearing Caps .....	72 (10)
Connecting Rod Caps .....	41 (5.7)
Flywheel .....	67 (9.2)
Camshaft Cap .....	9 (1.2)
Torque Converter .....	35 (4.8)
Camshaft Cover .....	5-6 (.7-8)
Rear Engine Mount-to-Body	
$\frac{5}{16}$ " Bolt .....	14-18 (1.9-2.5)
$\frac{3}{8}$ " Bolt .....	27-32 (3.7-4.4)
Front Engine Bracket-to-Beam .....	14-18 (1.9-2.5)

### ENGINE SPECIFICATIONS

#### GENERAL SPECIFICATIONS

Year	Displ.		Carburetor	HP at RPM	Torque (Ft. Lbs. at RPM)	Compr. Ratio	Bore		Stroke	
	cu. ins.	cc					in.	mm	in.	mm
1980	258.4	4235	Fuel Inj.	.....	.....	8.1:1	3.625	92.07	4.173	106

#### VALVES

Engine & Valve	Head Diam. In. (mm)	Face Angle	Seat Angle	Seat Width In. (mm)	Stem Diameter In. (mm)	Stem Clearance In. (mm)	Valve Lift In. (mm)
4235 cc Intake	1.75 (44.45)	45°	45°	.....	.310-.3125 (7.87-7.94)	.001-.004 (.025-.10)	.375 (9.525)
Exhaust	1.625 (41.28)	45°	45°	.....	.310-.3125 (7.87-7.94)	.001-.004 (.025-.10)	.375 (9.525)

#### CAMSHAFT

Engine	Journal Diam. In. (mm)	Clearance In. (mm)	Lobe Lift In. (mm)
4235 cc	.9990-.9995 (25.375-25.387)	.0005-.002 (.013-.05)	.....

#### VALVE TIMING

Engine	INTAKE		EXHAUST	
	Open (BTDC)	Close (ABDC)	Open (BBDC)	Close (ATDC)
4235cc	15°	57°	57°	15°

# Jaguar Engines

## XJ6 6 CYLINDER (Cont.)

### ENGINE SPECIFICATIONS (Cont.)

PISTONS, PINS, RINGS						
Engine	PISTONS	PINS		RINGS		
	Clearance In. (mm)	Piston Fit In. (mm)	Rod Fit In. (mm)	Rings	End Gap In. (mm)	Side Clearance In. (mm)
4235 cc	.0007-.0013 (.018-.033)	① Press Fit	② Push Fit	No. 1	.015-.020 (.38-.51)	.0015-.0035 (.038-.089)
				No. 2	.009-.014 (.23-.35)	.0015-.0035 (.038-.089)
				Oil	.015-.045 (.38-1.14)	③

① — When heated to 230°F (110°C).    ② — At room temperature, without piston.    ③ — Self-expanding.

CRANKSHAFT MAIN & CONNECTING ROD BEARINGS							
Engine	MAIN BEARINGS				CONNECTING ROD BEARINGS		
	Journal Diam. In. (mm)	Clearance In. (mm)	Thrust Bearing	Crankshaft End Play In. (mm)	Journal Diam. In. (mm)	Clearance In. (mm)	Side Play In. (mm)
4235 cc	2.749-2.750 (69.85-69.86)	.0008-.0025 (.020-.063)	Center	.004-.006 (.10-.15)	2.086-2.0866 (52.98-53.00)	.001-.0027 (.025-.069)	.0058-.0087 (.147-.221)

VALVE SPRINGS			
Engine	Free Length In. (mm)	PRESSURE Lbs. @ In. (kg @ mm)	
		Valve Closed	Valve Open
4235 cc Inner	1.734 (44.04)	.....	.....
Outer	2.103 (53.42)	.....	.....