

210 & 310 4 CYLINDER

ENGINE CODING

ENGINE IDENTIFICATION

Engine serial and code number is stamped on right rear side of cylinder block, below mating surface of cylinder head and cylinder block. First 3 or 4 digits are engine code.

Engine Identification	
Application	Code
210 (1237 cc)	A12A
210 & 310 (1397 cc)	A14
210 (1488 cc)	A15

ENGINE, CYLINDER HEAD & MANIFOLDS

ENGINE

NOTE — *Manufacturer recommends that engine and transmission be removed as an assembly.*

Removal (210) — 1) Disconnect battery ground and fusible links. Mark hood location and remove hood. Remove engine protective undercover. Drain coolant and engine oil.

2) Remove radiator. Disconnect electrical wires and other lines attached to air cleaner, then remove air cleaner assembly. Disconnect accelerator cable from carburetor. Disconnect the following components:

- Automatic choke wire.
- Throttle solenoid or throttle switch.
- Fuel cut solenoid.
- Vacuum switching valve.
- Coil and distributor.
- Thermal transmitter.
- Alternator and oil pressure switch.
- Engine ground and coil at engine wiring harness.
- Fuel pump and necessary emission control hoses.
- Water temperature switch.
- Vacuum switch.
- Battery cable to starter.

3) On models equipped with air conditioning, loosen compressor and lay out of the way without disconnecting any hoses. On models with manual transmissions, remove clutch slave cylinder. On all models, disconnect speedometer cable from extension housing. Remove shift linkage.

4) On manual transmission models, remove gear shift lever. On models with automatic transmissions, disconnect selector lever. On all models, disconnect exhaust at manifold and exhaust mounting bracket from transmission and hang up with wire.

5) Index mark and remove propeller shaft. Plug opening in rear of extension housing. Support transmission with a jack. Remove rear crossmember mounting bolts. Attach hoist to engine and raise slightly to support engine weight. Remove front engine mounts and remove engine and transmission as a unit.

Installation — To install, reverse removal procedure.

Removal (310) — 1) Remove hood and battery and drain coolant. Disconnect ducting and tubes to air cleaner and

remove air cleaner assembly. Disconnect accelerator cable. Remove radiator grille.

2) Disconnect following components so they are free when engine and transmission assembly is lifted out:

- Coil and distributor wires.
- Coil wires at block connector.
- Fusible links.
- Engine wiring harness.
- Fuel pump.
- Radiator and heater hoses.
- Master-Vac vacuum line.
- Air pump and carbon canister.
- Battery cables.
- Bonding wire (near strut mounting).

3) Remove carbon canister, auxiliary fan and washer tank. Remove radiator together with auxiliary fan motor. Remove clutch slave cylinder and disconnect speedometer cable. Remove buffer (damper) rods.

4) On models equipped with air conditioning, loosen air conditioning equipment and lay components out of way. Do not discharge system. Disconnect shift linkage. Attach hoist to engine.

5) Disconnect exhaust system at manifold, rear engine mount and "U" clamp. Disconnect both axle drive shafts at transaxle case. Lower out shift linkage. Disconnect engine mounts and lift out engine.

Installation — Install in reverse order of removal, ensuring that buffer (damper) rods are adjusted so that rubber will not be deformed.

INTAKE & EXHAUST MANIFOLDS

Removal & Installation — 1) Remove air cleaner and disconnect accelerator cable and choke cable. Disconnect and plug fuel line at carburetor. Disconnect exhaust pipe at exhaust manifold.

2) Remove nuts retaining intake and exhaust manifold to cylinder head and remove intake and exhaust manifold as an assembly. Remove gasket and thoroughly clean mating surfaces. Remove bolts and separate intake and exhaust manifold. To install, reverse removal procedure and use new gasket. Tighten nuts and bolts to specifications.

CYLINDER HEAD

Removal — Remove manifold assembly and take off rocker arm cover. Loosen valve adjusting screws to take tension off push rods. Remove rocker shaft assembly and withdraw push rods, keeping them in order for installation. Loosen head bolts gradually in reverse of tightening sequence and remove cylinder head. See Fig. 1.

Installation — Thoroughly clean mating surfaces. Use new gasket with no sealer and install cylinder head. Install cylinder head retaining bolts and tighten in 2 or 3 steps to specifications. Follow sequence shown in Fig. 1. Reverse removal procedure to install remaining components. Adjust valve clearance.

NOTE — *One cylinder head bolt is smaller diameter and has a hollow head. Install this bolt on right side center of cylinder head.*

210 & 310 4 CYLINDER (Cont.)

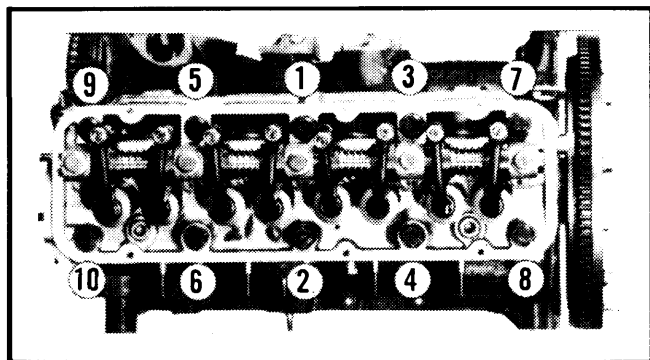

Fig. 1 Tightening Sequence for Cylinder Head (Loosen in Reverse Sequence)

VALVES

VALVE ARRANGEMENT

E-I-I-E-E-I-I-E (front to rear).

VALVE GUIDE SERVICING

Check valve stem-to-guide clearance. If clearance is more than .0039" (.1 mm) and valve stem is not worn, valve guide must be replaced. Replace valve guide using the following procedure:

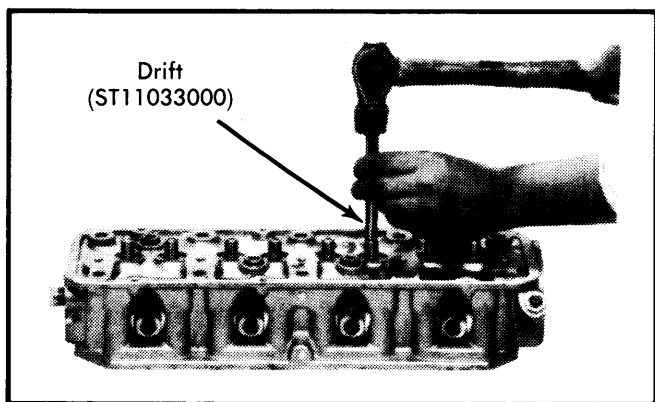

Fig. 2 Valve Guide Removal

1) Heat cylinder head to 302-392°F (150-200°C) to ease removal and installation and use suitable drift (ST11033000) to drive old guides out toward combustion chamber. Ream guide hole to .480" (12.2 mm) with head at room temperature.

2) With head heated, press new guide in position. Use suitable reamer (ST110320000) to finish stem bore to .31" (8.0 mm) and reface valve seat surface.

VALVE STEM OIL SEALS

Valve stem lip seals are used on all guides. Valve spring seat must be in position, then place seal on guide. Tap installer tool (KV10104800) with plastic hammer to ensure proper position of seal on guide.

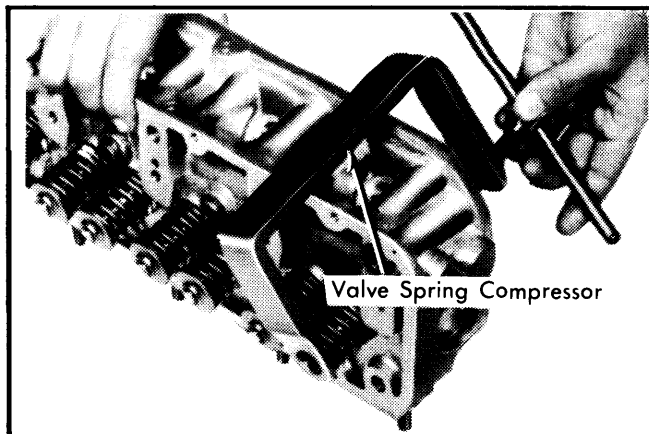

Fig. 3 Valve Spring Removal & Replacement

VALVE SPRINGS

Removal — With cylinder head removed, compress valve spring using a suitable valve spring compressor (ST12070000) and remove valve keepers. Release spring compressor and remove spring retainer and spring.

Installation — Install spring seat and oil seal, then insert valve in guide carefully to avoid damaging lip of seal. Install spring with close coiled end (painted white) toward head. Install retainer and keepers, ensuring that keepers are in proper position by tapping with plastic hammer.

VALVE SPRING INSTALLED HEIGHT

Valve spring must be square within $\frac{1}{16}$ ". Valve spring installed height is 1.52" (38.7 mm). Check valve spring by applying specified load and measuring spring height. If spring height and pressure, or squareness does not meet specifications, replace spring.

ROCKER ARM & SHAFT ASSEMBLY

1) Remove valve cover and loosen valve adjusting screws to remove tension. Loosen rocker arm assembly mounting bolts evenly and remove rocker arm and shaft assembly.

2) Slide off support stands, rocker arms and springs. Thoroughly clean and inspect all components for signs of wear or seizure. Measure rocker arm-to-shaft clearance by measuring diameter of rocker arm bore and shaft. Standard clearance is .0008-.0021" (.020-.054 mm). Replace as necessary.

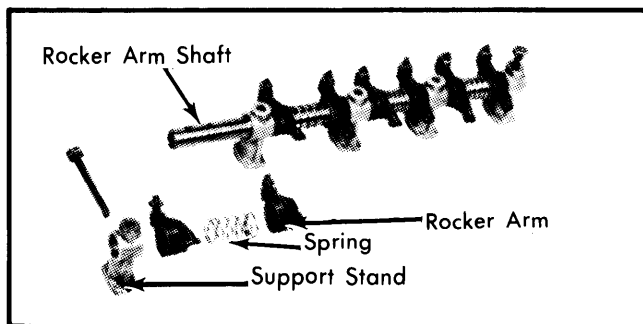

Fig. 4 Rocker Arm and Shaft Assembly

210 & 310 4 CYLINDER (Cont.)

3) If valve contact surface of rocker arm is worn, resurface using a suitable grinder.

4) Reverse disassembly and removal procedures to assemble and install rocker arm assembly. Tighten bolts to specifications and adjust valve clearance.

VALVE CLEARANCE

Set valves to .010" (.25 mm) cold for assembly purposes. Rotate crankshaft until No. 1 cylinder is at TDC on compression stroke and adjust as follows:

- No. 1 Exhaust and Intake.
- No. 2 Intake.
- No. 3 Exhaust.

Rotate crankshaft and bring No. 4 cylinder to TDC on compression stroke and adjust remaining valves.

- No. 2 Exhaust.
- No. 3 Intake.
- No. 4 Intake and Exhaust.

Warm engine to normal operating temperature and repeat adjustment procedure. Set clearance to .014" (.35 mm).

PISTONS, PINS & RINGS**PISTON & ROD ASSEMBLY**

1) Remove cylinder head and oil pan. Remove nuts from connecting rod and remove connecting rod cap with bearing half. Push piston and connecting rod assembly with bearing half up and out through top of cylinder block.

2) To install piston and connecting rod assembly, thoroughly oil rings, piston and cylinder wall. Make sure ring gaps are situated approximately 180° apart and not on thrust side of piston. See Fig. 5. Make sure bearing halves are properly seated in connecting rod and cap.

3) Install a ring compressor and compress rings. Install piston in cylinder with number on top of piston toward front of engine. With piston installed in cylinder, and connecting rod and bearings seated against crankshaft journal, install rod cap with numbers on the same side as connecting rod. Tighten nuts to specification.

4) Install cylinder head and oil pan as previously outlined.

FITTING PISTONS

1) Check piston-to-cylinder clearance with a feeler gauge and spring tension gauge. With a .0016" (.04 mm) feeler gauge installed between piston and cylinder wall, a force of 1.1-3.3 lbs. (.5-1.5 kg) measured on spring tension gauge, should be needed to extract feeler gauge.

NOTE — It is recommended that piston and cylinder be at 68°F (20°C).

2) Measure piston diameter at top of skirt 90° to piston pin axis. Measure cylinder bore halfway down cylinder and

90° to crankshaft center line. Pistons and rings are available in standard and 3 oversizes.

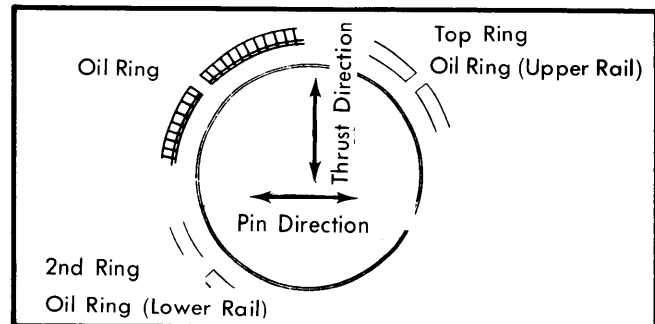

Fig. 5 Piston Ring Gap Positioning

Piston Specifications

Application In. (mm)	Piston Size In. (mm)
A12A	
Std.	2.9515-2.9534 (74.967-75.017)
.0008 (.020) O/S	2.9522-2.9542 (74.987-75.037)
.020 (.50) O/S	2.9715-2.9734 (75.467-75.517)
.040 (1.0) O/S	2.9909-2.9928 (75.967-76.017)
A14 & A15	
Std.	2.9908-2.9928 (75.967-76.017)
.0008 (.020) O/S	2.9916-2.9936 (75.987-76.037)
.020 (.50) O/S	3.0105-3.0125 (76.467-76.517)
.040 (1.0) O/S	3.0302-3.0322 (76.967-77.017)

NOTE — If cylinder bore has exceeded wear limit, undersize cylinder liners are available. Liners are installed with an interference fit .0031-.0035" (.08-.09 mm).

PISTON PIN REPLACEMENT

1) Remove piston and connecting rod assembly as previously outlined. Use a press and suitable pin press stand to remove and install pin in piston/rod assembly.

2) Check piston-to-pin clearance by measuring pin and hole diameters. If clearance is not within specifications, replace both piston and piston pin. Piston pin should push fit by hand through piston with both piston and pin at room temperature.

3) Piston pin should be press fit into connecting rod. If interference fit is not within specifications, replace connecting rod or piston pin as necessary. If connecting rod is replaced, ensure weight difference between rods is within .176 ounces (5 grams).

4) To assemble piston and connecting rod assembly, use same mandral and driver used for disassembly. Thoroughly oil pin, piston and connecting rod. Install piston on connecting rod so that number on top of piston is pointing toward front of engine and oil squirt hole on connecting rod is toward right side of crankcase.

210 & 310 4 CYLINDER (Cont.)

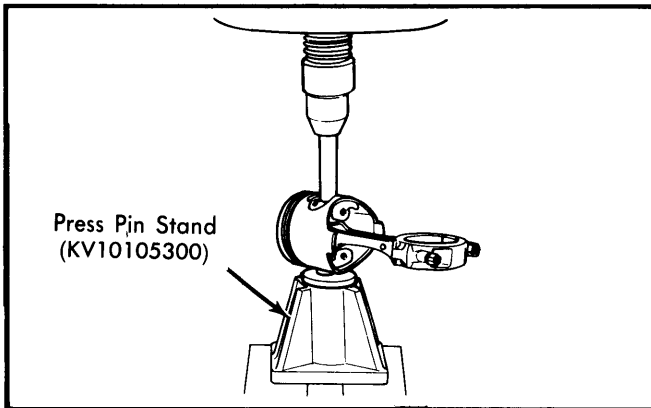

Fig. 6 Removing and Installing Piston Pin

CRANKSHAFT MAIN & CONNECTING ROD BEARINGS

MAIN & CONNECTING ROD BEARINGS

Removal — With engine removed from vehicle, remove cylinder head, oil pan, and piston and connecting rod assemblies. Remove alternator and engine mounting bracket from left side. Remove water pump, crankshaft pulley, and timing chain cover. Remove oil thrower and chain tensioner. Remove camshaft sprocket bolt, and remove both sprockets and timing chain as an assembly. Remove clutch and flywheel. Loosen main bearing cap bolts in two or three steps, then remove caps. Remove rear oil seal and carefully lift out crankshaft.

Inspection — 1) Thoroughly clean and inspect crankshaft. Blow out oil passages with compressed air. Check crankshaft for runout on center main bearing journal. If runout is more than .002" (.05 mm), crankshaft is bent and must be replaced.

2) Check all main and connecting rod bearings using Plastigage method. Check main and connecting rod journals for out-of-round or taper. If more than .0012" (.03 mm), crankshaft must be ground to next undersize. Main and connecting rod journals may be ground to the undersizes indicated in tables.

Main Bearing Journals	
Application In. (mm)	Diameter In. (mm)
Std.	1.9663-1.9671 (49.943-49.964)
.01 (.25) U/S	1.9567-1.9572 (49.701-49.714)
.02 (.50) U/S	1.9469-1.9474 (49.451-49.464)
.03 (.75) U/S	1.9378-1.9376 (49.201-49.214)

Installation — 1) Install main bearing halves to engine block ensuring that all bearings are on correct journal. Bearings for journal No. 1 and No. 5 are the same. Bearings for journals No. 2 and No. 4 are the same. Journal No. 3 requires the thrust bearing. Upper and lower bearings are not interchangeable except for journals No. 2 and No. 4.

Connecting Rod Journals	
Application In. (mm)	Diameter In. (mm)
Std.	1.7698-1.7706 (44.958-44.974)
.003 (.08) U/S	1.760-1.7675 (44.881-44.894)
.01 (.25) U/S	1.7603-1.7608 (44.711-44.724)
.02 (.50) U/S	1.7504-1.7509 (44.461-44.474)
.03 (.75) U/S	1.7406-1.7411 (44.211-44.224)

2) Apply oil to main bearing surface and install crankshaft. Install main bearing caps with arrow pointing toward front of engine. Tighten main bearing caps in 2 or 3 steps, starting at center bearing and working outward. Ensure crankshaft rotates smoothly.

NOTE — Apply sealer to rear main bearing cap at point where cap contacts cylinder block.

3) Check crankshaft end play. See *Thrust Bearing Alignment*. Install timing chain in correct position with crankshaft and camshaft sprockets. Install rear oil seal. Install clutch and flywheel. Install oil thrower and chain tensioner. Install timing chain cover, crankshaft pulley, and water pump. Install alternator and engine mounting bracket. Install piston and connecting rod assemblies, oil pan, and cylinder head.

THRUST BEARING ALIGNMENT

Thrust bearing is installed on No. 3 main bearing journal. Check crankshaft end play by inserting a feeler gauge between flange of thrust bearing and crankshaft. End play should be .002-.006" (.05-.15 mm). Service limit is .012" (.30 mm).

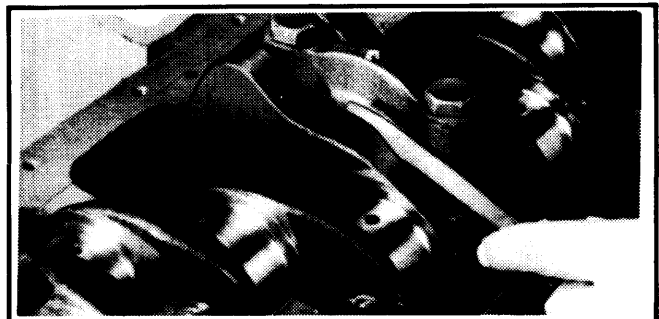

Fig. 7 Checking Crankshaft End Play

REAR MAIN BEARING OIL SEAL

Apply sealer to corners of crankcase at rear main bearing cap contact points and install cap. Lubricate seal lips and drive seal into position with suitable installer.

ENGINE FRONT COVER & OIL SEAL

Removal & Installation — Remove drive belt, fan, and water pump pulley. Remove water pump and crankshaft pulley. Remove oil pan and front cover. Replace seal in front cover whenever cover is removed. Thoroughly clean mating surfaces and apply sealer to both sides of gasket. Install gasket and cover. Tighten bolts and nuts to specifications. Reverse removal procedure to install remaining components.

210 & 310 4 CYLINDER (Cont.)

CAMSHAFT

TIMING CHAIN

Removal — Remove engine front cover as previously outlined. Remove timing chain tensioner and bolt securing camshaft sprocket to camshaft. Pull off sprocket with timing chain.

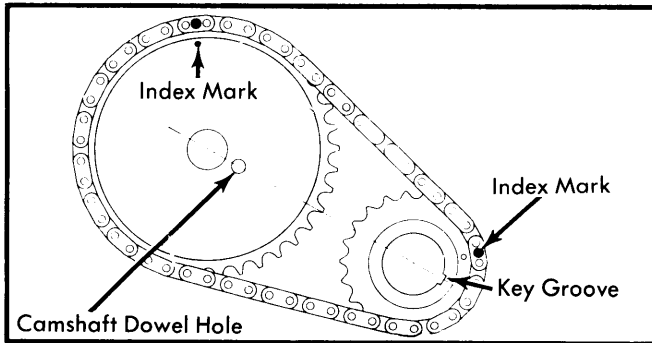

Fig. 8 Timing Chain Alignment Marks for Installation

Installation — 1) Insert crank sprocket keys in keyways of crankshaft. Install camshaft and crankshaft sprockets temporarily for adjustment of tooth height by using adjusting washers. Adjust height difference so it is less than .020" (0.5 mm).

2) Install timing chain and camshaft sprocket with markings on chain and sprockets correctly aligned. See Fig. 8. Oil sprocket teeth and chain with engine oil. Install and tighten camshaft sprocket bolt. Install chain tensioner and tighten attaching bolts. Check dimension "L" of tensioner and if over .591" (15 mm), replace chain. See Fig. 9. Install oil thrower in front of camshaft sprocket. Install timing chain cover.

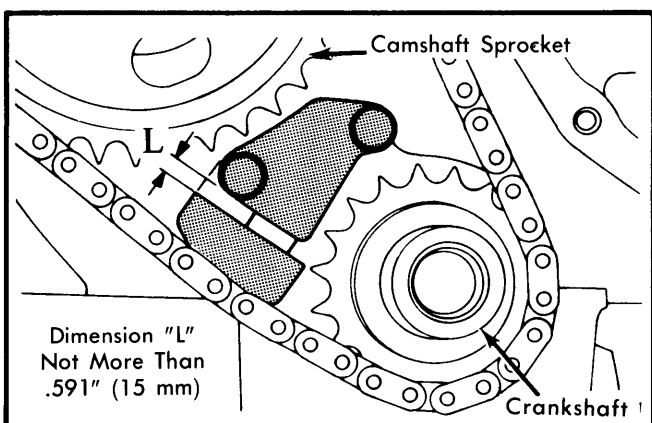

Fig. 9 Checking Timing Chain Tensioner Projection

CAMSHAFT

Removal — Remove engine front cover, and valve train components as previously outlined. Remove fuel pump and oil pump with filter. Remove timing chain tensioner and remove timing chain with sprockets. Remove two bolts from camshaft lock plate and carefully pull camshaft from engine block.

Inspection — Thoroughly clean and inspect camshaft for wear or scoring. Check runout of camshaft using a dial indicator on center bearing journal. If runout exceeds .002" (.05 mm), replace camshaft. Check journal diameter, and if diameter is more than .0039" (.10 mm) from standard, camshaft journals must be ground to next undersize. Bearings are available in standard and three undersizes.

Installation — Coat camshaft with light coat of engine oil and carefully install camshaft into engine. Install camshaft lock plate with word "LOWER" at bottom. Install valve train components. Install timing chain with sprockets and timing chain tensioner. Install engine front cover. Install fuel pump and oil pump.

CAMSHAFT END THRUST

Check camshaft end thrust with camshaft, lock plate, and camshaft sprocket in position by using a dial indicator on camshaft sprocket bolt. If end play exceeds .0039" (.10 mm), replace lock plate.

CAMSHAFT BEARING REPLACEMENT

1) With camshaft removed, check journal diameter and bearing inside diameter. If journal measurement is within tolerance and clearance between camshaft journals and bearings exceeds .0059" (.15 mm), bearings must be replaced.

2) Remove and install appropriate bearings in crankcase using a suitable driver (ST16110000). Make sure oil holes in bearings align with oil holes in crankcase. Bearings must be line bored after installation. Install taper plug in crankcase using sealer. Install camshaft as previously outlined.

ENGINE OILING

Crankcase Capacity (With Filter)

Application	Quantity
A12A (1237 cc)	3 ³ / ₈ quarts
A14 (1397 cc)	3 ³ / ₈ quarts
A15 (1488 cc)	3 ¹ / ₄ quarts

Oil Filter — Full-flow, replaceable element.

Oil Pressure — More than 11 psi (.8 kg/cm²) at idle; 54-74 psi (3.8-5.2 kg/cm²) at 3000 RPM.

Pressure Relief Valve — Nonadjustable, located in oil pump cover.

ENGINE OILING SYSTEM

Oil is circulated through engine by pressure provided by a trochoid rotor type pump. Oil pump is mounted on side of crankcase and driven by camshaft. Oil is drawn from oil pan by oil pump and into full flow oil filter mounted under oil pump. Oil is then pumped into main oil gallery of crankcase where it is distributed to crankshaft journals, timing chain tensioner and squirter that lubricates timing chain. Oil is circulated from crankshaft main bearing journals to camshaft journals and from center camshaft journal to rocker arm shaft

210 & 310 4 CYLINDER (Cont.)

to lubricate rocker arms and valves. Cylinder walls and piston pins are lubricated by oil squirted from squirt hole in connecting rod.

OIL PUMP

Removal & Installation — Place suitable drain pan under oil pump/filter assembly and remove oil filter with oil filter wrench. Remove 3 pump mounting bolts. Take out bolt securing cover to body and check all clearances with a feeler gauge. If beyond wear limit replace entire pump assembly. To install, reverse removal procedure.

Oil Pump Specifications	
Application	Wear Limit In. (mm)
Rotor-to-Rotor Side Clearance0024 (.06)
Rotor-to-Tip Clearance0079 (.20)
Rotor-to-Pump Body0197 (.50)
Regulator Valve Spring	
Free Length	1.71 (43.49)
Length at 8.09 lbs. (3.67 kg)	1.19 (30.3)

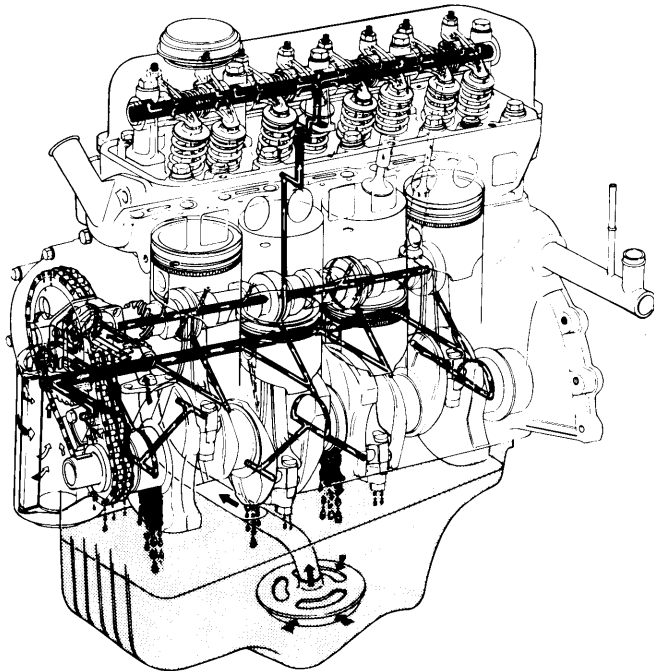

Fig. 10 Engine Oiling System

ENGINE COOLING

WATER PUMP

Removal & Installation — Drain coolant. On 310, loosen belt and remove fan and pulley. On 210, loosen bolts retaining shroud to radiator and remove shroud. On air conditioned 210 models, remove fan blade from torque coupling and remove torque coupling and pulley from hub. On all models, remove water pump and gasket from front cover. To install, use new gasket and reverse removal procedure. Be sure to clean gasket contact surfaces.

Thermostat — Opens at 180°F (82°C).

Cooling System Capacity	
Application	Quantity
210 With Heater	
Auto. Trans.	6 quarts
Man. Trans.	6¼ quarts
210 Without Heater	
Auto. Trans.	5¼ quarts
Man. Trans.	6½ quarts
310	
With Heater	6¼ quarts
Without Heater	5⅝ quarts

ENGINE SPECIFICATIONS

GENERAL SPECIFICATIONS

Year	Displ.		Carburetor	HP at RPM	Torque (Ft. Lbs. at RPM)	Compr. Ratio	Bore		Stroke	
	cu. ins.	cc					in.	mm	in.	mm
1980										
A12A	75.5	1237	1 x 2-Bbl.	8.5:1	2.76	70	2.95	75
A14	85.2	1397	1 x 2-Bbl.	8.9:1	2.99	76	3.03	77
A15	90.9	1488	1 x 2-Bbl.	8.9:1	2.99	76	3.23	82

VALVES

Engine & Valve	Head Diam. In. (mm)	Face Angle	Seat Angle	Seat Width In. (mm)	Stem Diameter In. (mm)	Stem Clearance In. (mm)	Valve Lift In. (mm)
All Int.	1.46 (37)	45.5°	45.5°	.059 (1.5)	.3138-.3144 (7.970-7.985)	.0006-.0018 (.015-.045)	.3114 (7.91)
Exh.	1.18 (30)	45.5°	45.5°	.075 (1.9)	.3128-.3134 (7.945-7.960)	.0016-.0028 (.040-.070)	.3236 (8.22)

Datsun Engines

210 & 310 4 CYLINDER (Cont.)

ENGINE SPECIFICATIONS (Cont.)

VALVE SPRINGS			
Engine	Free Length In. (mm)	PRESSURE Lbs. @ In. (kg @ mm)	
		Valve Closed	Valve Open
All	1.831 (46.5)	56.4@1.189 25.6@30.2

VALVE TIMING				
Engine	INTAKE		EXHAUST	
	Open (BTDC)	Close (ABDC)	Open (BBDC)	Close (ATDC)
A12A	14°	54°	56°	12°
A14 & A15	14°	54°	56°	20°

PISTONS, PINS, RINGS						
Engine	PISTONS		PINS		RINGS	
	Clearance In. (mm)	Piston Fit In. (mm)	Rod Fit In. (mm)	Rings	End Gap In. (mm)	Side Clearance In. (mm)
All	.0010-.0018 (.025-.045)	.0003-.0005 (.008-.012)	.0007-.0014Ⓢ (.017-.035)	1	.0079-.0138 (.20-.35)	.0016-.0028 (.04-.07)
				2	.0059-.0118 (.15-.30)	.0012-.0024 (.03-.06)
				Oil	.0118-.0354 (.30-.90)	snug

Ⓢ - Interference fit.

CRANKSHAFT MAIN & CONNECTING ROD BEARINGS							
Engine	MAIN BEARINGS				CONNECTING ROD BEARINGS		
	Journal Diam. In. (mm)	Clearance In. (mm)	Thrust Bearing	Crankshaft End Play In. (mm)	Journal Diam. In. (mm)	Clearance In. (mm)	Side Play In. (mm)
All	1.9663-1.9671 (49.94-49.96)	.0010-.0035 (.026-.090)	No. 3	.0020-.0059 (.050-.150)	1.7698-1.7706 (44.95-44.97)	.0012-.0031 (.030-.079)	.004-.008 (.1-.2)

CAMSHAFT			
Engine	Journal Diam. In. (mm)	Clearance In. (mm)	Lobe Lift In. (mm)
All No. 1	1.7237-1.7242 (43.78-43.80)	.0015-.0024 (.037-.060)	Int. .222 (5.65)
2	1.7041-1.7046 (43.28-43.30)	.0011-.0020 (.027-.050)	Exh. .233 (5.92)
3	1.6844-1.6849 (42.78-42.80)	.0016-.0025 (.040-.063)	
4	1.6647-1.6652 (42.28-42.30)	.0011-.0020 (.029-.050)	
5	1.6224-1.6229 (41.21-41.22)	.0015-.0024 (.037-.060)	

TIGHTENING SPECIFICATIONS	
Application	Ft. Lbs. (mkg)
Cylinder Head	51-54 (7.0-7.5)
Connecting Rod	23-27 (3.2-3.8)
Main Bearing Caps	36-43 (5.0-6.0)
Camshaft Sprocket	29-35 (4.0-4.8)
Camshaft Lock Plate	3.6-5.8 (.5-.8)
Timing Chain Tensioner	4.3-5.8 (0.6-0.8)
Front Cover	3.6-5.1 (.5-.7)
Oil Pan	2.9-4.3 (.4-.6)
Oil Pump	6.5-10.1 (.9-1.4)
Rocker Arm Shaft	14-18 (2.0-2.5)
Manifolds	11-14 (1.5-2.0)
Crankshaft Pulley	108-145 (15-20)
Flywheel	58-65 (8.0-9.0)
Oil Strainer	6.5-10 (.9-1.4)
Engine Mounts	14-18 (1.9-2.5)
Water Pump	6.5-10.0 (.9-1.4)