

PEUGEOT SPLIT HOUSING (I.R.S.)

504
604

DESCRIPTION

Hypoid type differential is housed in a split case which is bolted to the rear suspension cross member. A torque tube houses the drive shaft which is splined to the drive pinion. Ribbed aluminum alloy housing attaches to torque tube at front by flange and four nuts. Stub axle shafts (half shafts) are driven by differential side gears through tripod type joints.

AXLE RATIO & IDENTIFICATION

Axle ratio and identification may be found at the left front side of the housing next to the torque tube flange. To determine axle ratio, count number of pinion teeth and divide into number of ring gear teeth. Differential numbering such as "5.A. 0001" indicates 9X35 ratio, 4. indicates 9X34 ratio and 7. indicates 10X37 gear set.

REMOVAL & INSTALLATION

AXLE SHAFTS & BEARINGS

Removal – 1) Raise rear of vehicle and support under rear suspension arms. Remove rear wheels. Loosen but do not remove hub nut.

2) From rear brake caliper remove: anti-chatter spring, lock pin arrangement and brake disc pads. Open brake line clamp, located on lower control arm, and move brake line upward. Hang brake caliper from vehicle in such a way that brake line is not stressed.

3) Remove bolts attaching brake rotor to hub. Mark rotor-to-hub position and remove rotor.

4) With rotor removed, insert socket (on extension) through hole in hub. Remove bolts securing axle hub bearing support-to-lower control arm.

5) To remove axle complete with hub and bearing support, work from rear (see illustration) and use two bolts and plate (special tools B1, B2 and B3 of tool set 8.0521). With plate installed between hub and bearing support, insert the two bolts, as illustrated, and alternately tighten both bolts until axle assembly is pressed free of lower control arm.

6) With axle assembly pressed out of lower control arm, remove axle assembly from rear carrier housing. Remove axle assembly through lower control arm. With axle removed, place axle assembly in press, with adaptor plate located just below hub. Remove hub nut and washer. Press axle out of hub.

NOTE – When removing axle assembly from rear carrier, take care not to damage carrier seal.

Installation – To install, reverse removal procedures and observe the following precautions:

NOTE – When installing hub nut, hand tighten ONLY.

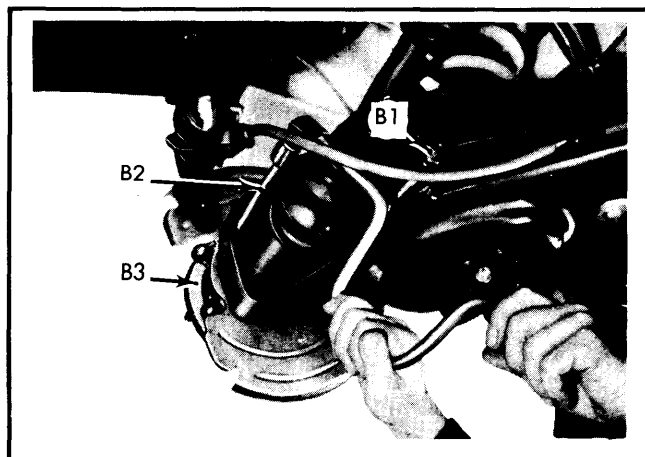

Fig. 1 Forcing Axle Assembly Out of Lower Control Arm (504 Shown)

1) Before assembling hub to axle bearing support, grease spline of axle stub. Before installing axle assembly into carrier housing, make sure carrier side seal is in perfect condition. Apply grease between lips of seal and to drive axle splines.

2) Use new washer, when assembling bearing support-to-lower control arm. Tighten bolts to specifications. When installing brake caliper, use new washers and tighten bolts to specifications. When installing brake anti-chatter spring onto caliper, make sure arrow of spring is facing normal direction of rotation.

3) When installing hub nut, tighten to specifications and peen the nut. After installing road wheels, check level of grease in carrier housing.

NOTE – Following procedures are written for 504. Procedures for 604 are similar.

PINION FLANGE & SEAL

Removal – 1) Raise and support vehicle. Remove exhaust pipe assembly and allow it to rest on rear crossmember. Remove both Allen screws securing carrier housing and allow housing to rest on rear crossmember.

2) Inside vehicle, remove rear seat cushions. Loosen three nuts on "T" shaped metal bracket and remove first nut. Bend up "T" bracket and remove plastic plug from guide hole. Insert special guide pin K1 into guide hole and tighten pin with special bar K2. Leave K2 in guide pin and remove other two lock nuts. Lower crossmember until special bar K2 is resting on floorboard. Repeat operation on opposite side.

3) Remove four nuts securing carrier housing to propeller shaft tube. Move carrier housing rearward and allow it to rest on wooden block. Remove spring located inside propeller shaft.

4) Remove seal support plate from front of carrier and place in vise. Thoroughly clean front oil seal housing and remove oil seal by using pry bar.

NOTE – When prying out old oil seal, take care not to damage insert deflector. Any damage to oil seal deflector necessitates replacement of complete oil seal housing.

Drive Axles

PEUGEOT SPLIT HOUSING (I.R.S.) (Cont.)

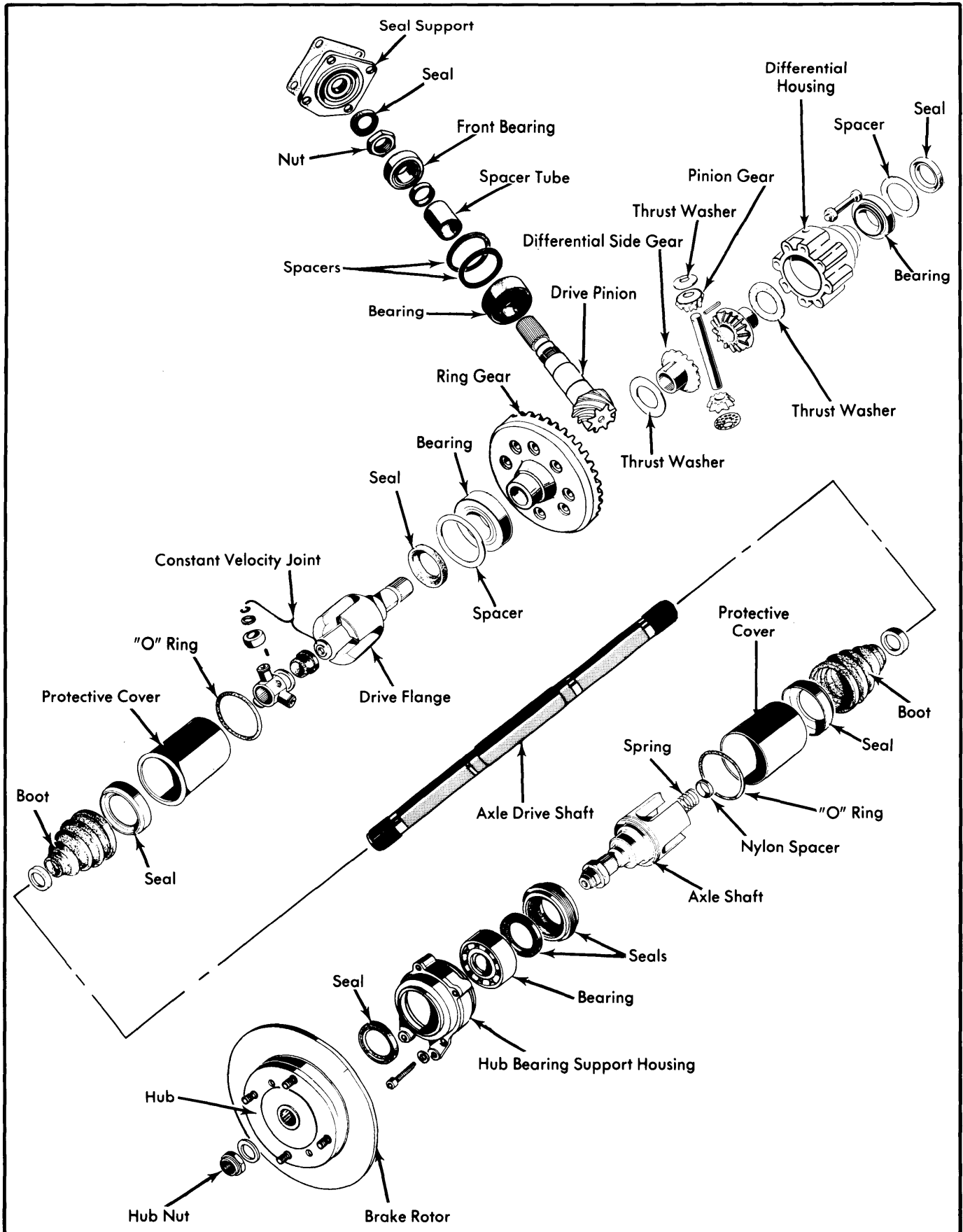

Fig. 2 Exploded View of Peugeot Independent Rear Suspension (I.R.S.) Drive Axle Assembly

PEUGEOT SPLIT HOUSING (I.R.S.) (Cont.)

5) Use seal driver to seat new oil seal in housing. Drive seal inward until it is flush with oil seal housing. Coat new seal in engine oil and place seal housing on carrier housing.

Installation — To install, reverse removal procedure and note the following precautions: Use all new washers and tighten all bolts to specifications.

DIFFERENTIAL ASSEMBLY

Removal — 1) Proceed as with *Axle Shafts & Bearings* and *Pinion Flange & Seal* removal and installation and continue as follows.

2) Drain differential. Remove brake compensator lever pivot from frame (504 only). On 604 only, remove rear muffler flexible mounting nuts and lower heat baffle.

3) Remove assembly by pulling to rear and then to the left. Propeller shaft must be held in position to prevent it from moving back with differential.

Installation — To install, reverse removal procedure noting that splines are greased and propeller shaft spring is placed into rear end of propeller shaft.

OVERHAUL

REAR HUBS & HUB CARRIER BEARING & SEALS

Disassembly — 1) Remove axle and hub assembly as previously outlined. With hub and axle removed, place assembly in press with adaptor plate beneath hub. Remove hub nut and press axle assembly out of hub.

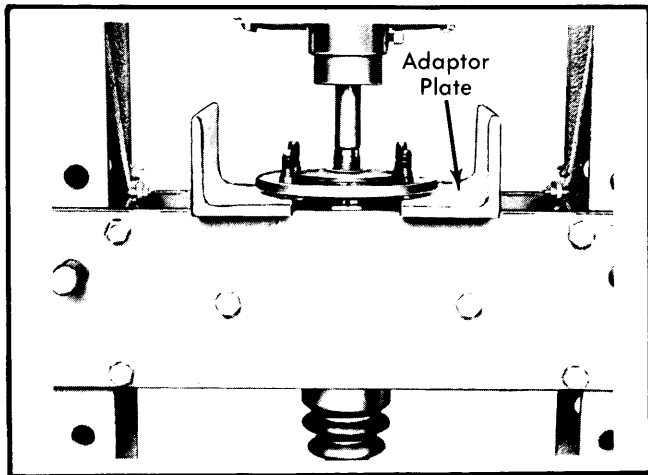

Fig. 3 Pressing Axle Shaft from Hub Assembly

2) Place hub-carrier assembly in soft jawed vise. To remove carrier nut, install spanner nut plate (special tool D) over carrier nut and lock spanner nut in place by inserting long bolt (special tool C1) upward through hub assembly. Use open end wrench on spanner and fulcrum advantage extension (see illustration). Unscrew and remove nut.

3) Place special tool C3 inside hub carrier and install puller (special tool C4 and C1) into hub carrier. Tighten puller bolt (C4) until hub is completely withdrawn.

4) Remove puller and thrust pad C3. Remove double bearing using nut C2 and a press. Turn carrier over, in the vise, and pry out seal.

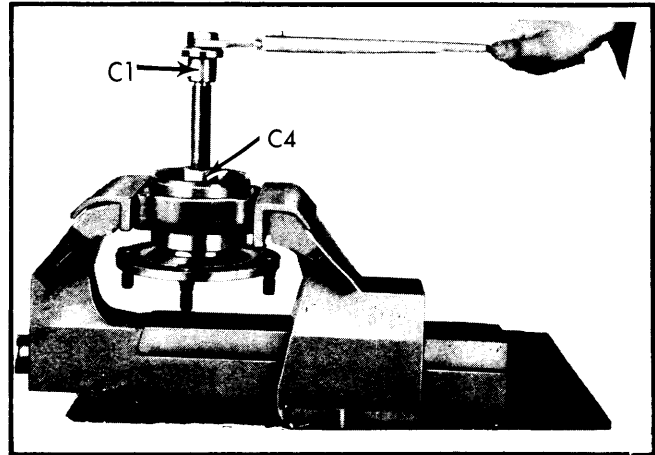

Fig. 4 Removing Double Bearing from Hub Assembly

Reassembly — 1) Use suitable drift (special tool E) to install oil seal into back side of hub carrier. Drive seal inward until seal is flush with hub carrier.

NOTE — All new bearings are fitted with plastic retainer (inside) which holds inner and outer races together. This plastic part must be removed before attempting to install new bearing. Grease bearing with Esso Multiple Purpose Grease H or its equivalent before installing.

2) Insert double lipped seal into carrier nut assembly using same drift (E). Insert bearing, with inner and outer races held together, into hub-carrier assembly.

NOTE — Installation of bearing must be completed with use of press or special tool. Procedure for using special tools will be only procedure described.

3) Tighten carrier nut until it contacts the bearing. Install C4 onto nut C1. Place spanner head "D" on carrier nut and insert bolt C1 fitted with puller C4 into hub carrier. Tighten this assembly into spanner head "D". Tighten carrier nut to 181 ft. lbs. (25 mkg) and remove special tools. Lock carrier nut by peening with punch.

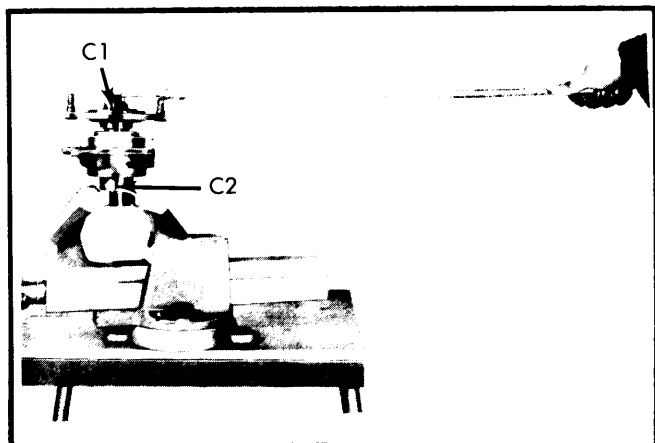

Fig. 5 Installing Hub into Support Housing

4) Install bolt C1 and nut C2 into carrier assembly. Install hub and screw down on nut C2 until nut contacts bearing. Coat splines of stub axle with Molycote 321 and insert stub axle into carrier assembly. Install washer and hub nut, hand tight. Install assembly onto vehicle in reverse order of disassembly.

PEUGEOT SPLIT HOUSING (I.R.S.) (Cont.)

NOTE — Overhaul procedures are written for 504 Independent Rear Suspension differentials. Procedures for 604 are similar.

DIFFERENTIAL

Disassembly — 1) With differential removed, as previously outlined, remove front oil seal support plate. Place carrier housing in holding fixture and place holding fixture in vise. Loosen all bolts and nuts of back half of housing. Remove front attaching screws of bearing side plates. Remove six bolts and four nuts holding two halves of housing together. Lift off rear half of housing. If necessary, use soft faced mallet to assist in removing rear half of housing.

2) Loosen vise and rotate holding fixture to allow front of housing to be in horizontal position. Install special spanner tool N (hexagonal sleeve with bolt tang) over end of drive pinion nut and secure to holding fixture with bolt through tang (see illustration). Install drive pinion holding socket M (splined socket) over pinion spline. To loosen drive pinion nut, pinion spline is turned clockwise while holding nut steady.

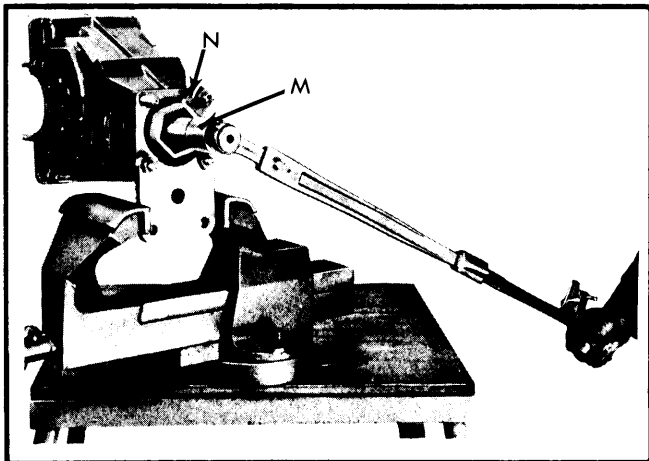

Fig. 6 Using Special Socket to Remove Drive Pinion

NOTE — Catch pinion as assembly is pressed out of housing.

3) Remove carrier housing from vise and remove holding fixture from carrier housing. Place housing in vise and press on drive end of pinion to remove drive pinion assembly.

4) To remove drive pinion rear bearing outer race, install parts of special puller-driver tool L. Install bolt L1, extractor L4 and support plate D. Turn bolt counterclockwise to remove outer race.

5) To remove drive pinion front outer race, install parts of special puller-driver tool L. Install bolt L1 and extractor L3. Turn bolt clockwise to remove front outer race. Now place drive pinion in vise and press off drive pinion rear tapered bearing. Special tool (collar) SZ is designed for this purpose and fits over drive pinion gear and against shoulder of rear bearing.

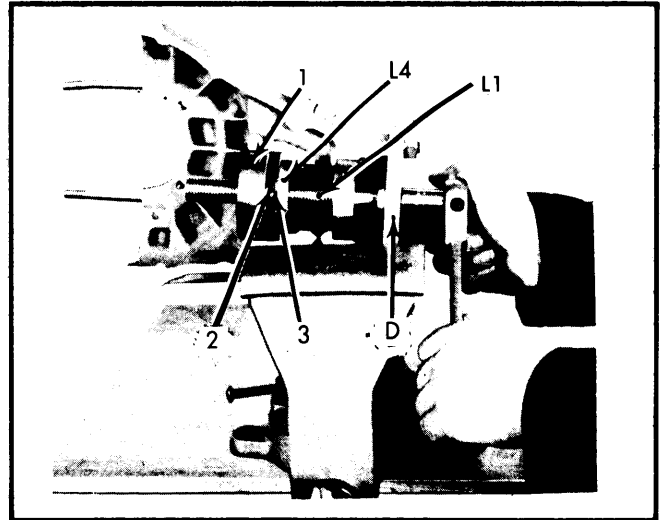

Fig. 7 Removing Drive Pinion Rear Outer Bearing Race

CAUTION — As parts are separated in following step, catch differential side gear and thrust washer to prevent damage.

6) To disassemble differential, remove bolts which hold differential housing to ring gear. Place special collar adaptor C over differential shaft. Insert four extractor clamp support rods H3 into four diagonally opposed holes of ring gear. Place special collar adaptor H1 around bearing (see illustration). Tighten Allen screws on adaptor plate to 14.5 ft. lbs. (2.0 mkg).

7) Place press pad H2 on ring gear, in center of bearing. Using press, remove ring gear. Use same procedure to remove bearing from differential case.

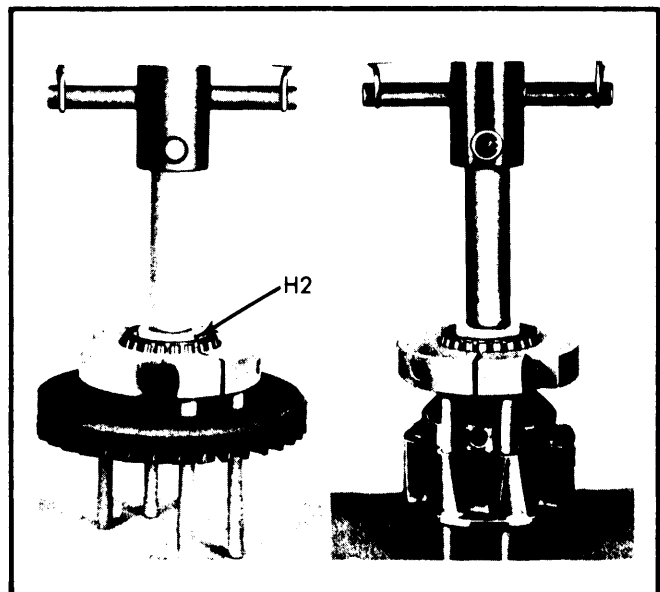

Fig. 8 Removing Differential Side Bearing

8) Use drift punch to remove differential pinion shaft-to-pinion gear retaining pin. Then remove pinion shaft, pinion gears, spacer washers, differential side gears and thrust washers.

PEUGEOT SPLIT HOUSING (I.R.S.) (Cont.)

NOTE — Emery cloth or sharp tools should NEVER be used to clean housing or other differential parts.

Reassembly & Adjustment — 1) Clean all parts in suitable solvent and blow dry with compressed air. Spray Molykote 321 into drive pinion housing. Do not heat housing. Every time ring gear and drive pinion are replaced, they must be replaced as an assembly and the following parts should also be changed: differential side bearings, drive pinion bearings, flex washers, drive pinion nut, differential assembling bolts, drive pinion seal and all other "O" rings and differential seals.

2) Before installing drive pinion rear bearing, check that front bearing slides freely on drive pinion shaft. If any difficulty is experienced, polish shaft bearing surface with fine abrasive until bearing just slides (as free fit) onto shaft. Smooth front of drive pinion shaft with stone to remove any burrs, since front end of shaft serves as contact point during various adjustments. With front bearing fit correct, install pinion rear bearing by using special sleeve C and end pad H2.

NOTE — Press down on bearing until bearing is in contact with drive pinion gear shoulder.

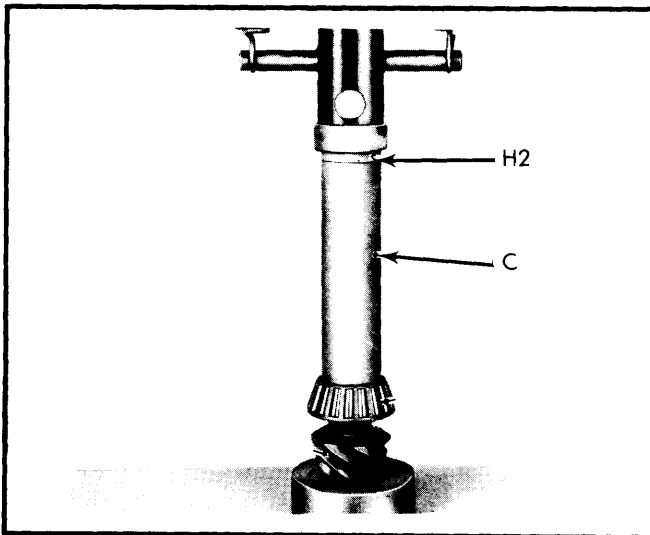

Fig. 9 Installing Drive Pinion Rear Bearing

3) Place forward half of carrier housing in holding fixture in vise so that housing is in horizontal position. Using special puller-driver, install thrust washer 3, outer bearing races 4 and 5 (back to back) into housing. Use bolt L1, thrust plate L2 and nut L5. Tighten bolt head of L1 to 101 ft. lbs. (14 mkg). Oil bearings with Esso Extra Oil 20 W 30/40. See Fig. 10.

4) Install drive pinion into housing with rear bearing, long spacer, front bearing and nut. Install special spanner tool (hexagon sleeve with bolt tang) over end of drive pinion nut and secure to holding fixture with bolt through tang (see illustration). Install drive pinion holding socket M (splined socket) over pinion spline. Torque nut to 7.2 ft. lbs. (1.0 mkg). Rotate drive pinion in both directions and again tighten nut. Continue operation until nut can no longer be tightened less than torque specification.

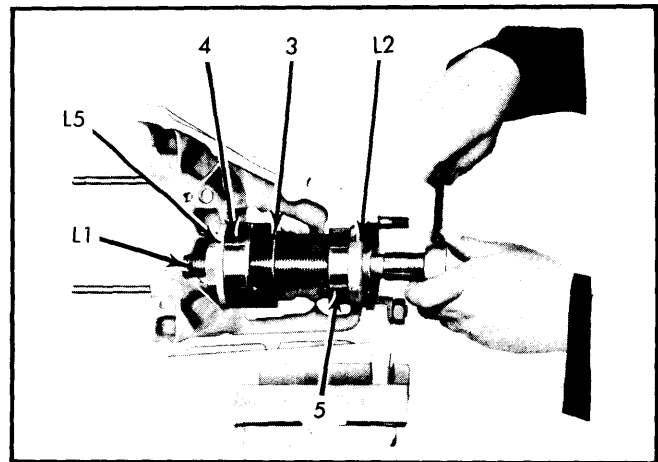

Fig. 10 Installing Drive Pinion Bearing Outer Race

5) Install special tool AZ (for measuring pinion depth) into front half of housing and hold in position by means of bridge clamp A3 (see illustration). Tighten nuts of clamp A3 to 7.2 ft. lbs. (1.0 mkg). Equalize distance between bridge pads and housing on both sides by using feeler gauges. Free feeler assembly A2 and ensure that it is in contact with drive pinion.

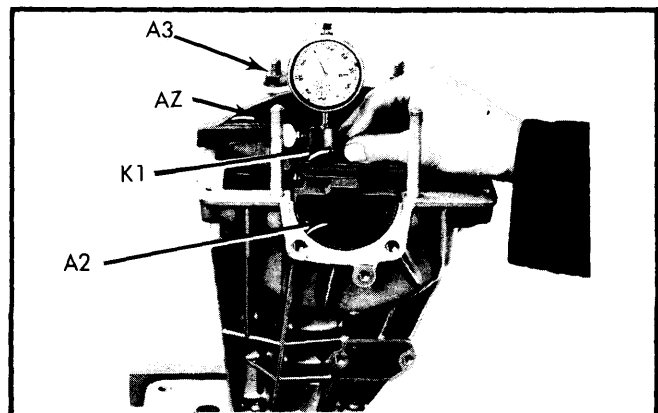

Fig. 11 Measuring Drive Pinion Installed Depth

6) Install dial indicator onto holder K1. Position latter so that dial indicator foot guide is resting on upper surface of A2. Adjust height of dial indicator so that small hand is set to "3" (for example). Turn dial face to zero indicator. Slide support K1 to bring dial indicator foot into contact with machined surface of AZ. Movement of dial indicator indicates depth of A2. Write down value obtained.

7) There are two reference marks on hypoid gear end of drive pinion; the first indicates pinion depth and the second corresponds with number of ring gear (matched set). Write down reference number (bottom number) marked on end of drive pinion. To this number, whether positive or negative, add $+.30$ mm.; to find corresponding guide number. Compare dial indicator reading previously obtained with guide number. The difference between the two numbers represents the thickness (in mm.) of shims to be installed between drive pinion rear bearing outer race and the thrust washer. To find corresponding guide number and to calculate thickness of shims, use sample calculation.

PEUGEOT SPLIT HOUSING (I.R.S.) (Cont.)

Sample Calculation

Constant Added to Determine Guide Number30
Number on End of Drive Pinion	-.04
Resulting Guide Number26
Dial Indicator Reading from Step 7)67
Subtract Guide Number (Obtained Above)	-.26
Total Shim Thickness Required	① .41

① - Hundredths of a millimeter (mm).

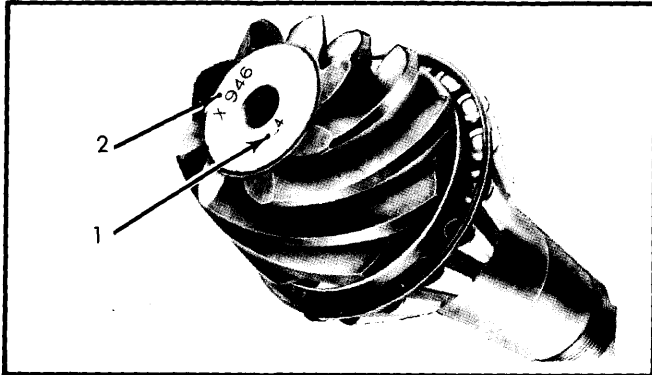

Fig. 12 Identification Marks on Drive Pinion Gear

8) Remove tool AZ and drive pinion from front housing. Use puller-driver tool to remove drive pinion rear bearing outer race from front housing. Install thrust washer and shims (previously determined) then reinstall rear bearing outer race. Torque puller-driver tool to 101 ft. lbs. (14 mkg), to seat.

9) Place drive pinion vertically on work bench and make colored chalk mark down full length of one spline (on drive pinion). Install long spacer, front bearing (fitted backward) and nut J. Place holding fixture N over nut J and use socket C to torque pinion to 203 ft. lbs. (28 mkg).

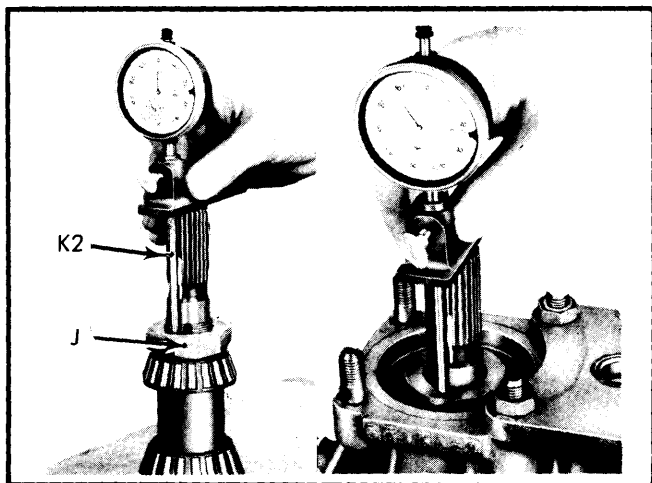

Fig. 13 Measuring Drive Pinion Depth

10) Screw dial indicator onto extension K2. Place dial indicator on end of drive pinion and make sure that extension K2 faces chalk mark on pinion spline and rests on machined surface of nut J. Move dial indicator to bring small hand to 1 and big hand to 0. Remove dial indicator and lay aside, mak-

ing sure reading is not changed. Remove nut J and front bearing. Place pinion into front housing with long spacer and front bearing. Torque nut J to 7.2 ft. lbs. (1 mkg). Rotate pinion 10 turns counterclockwise and retorquer.

11) With colored chalk mark as reference, take another reading, with dial indicator between end of shaft and nut J. Find difference between two readings and subtract .06 mm. The number thus obtained is the thickness of shims necessary between front bearing and long spacer. Install pinion into housing with long spacer, adjusting shims and new nut. Torque nut to 203 ft. lbs. (28 mkg). Use speed wrench attached to tool (socket) C to turn pinion by hand. Use special tool AZ, K1 and dial indicator as described in steps 5) and 6) to check pinion depth. Resulting number obtained should correspond to guide number, within the following tolerance: +.05 or -.03 mm.

NOTE - Shims are available in increments of .03 mm. Use shim closest to difference obtained in measurement.

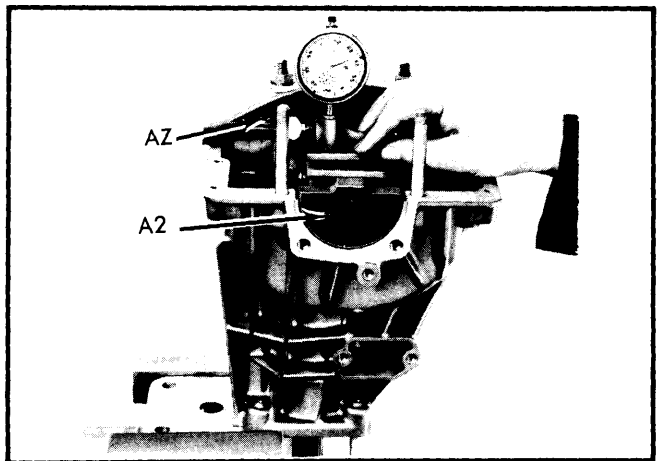

Fig. 14 Measuring Shim Thickness for Drive Pinion Depth

12) Reassemble differential side gear and pinion gears into differential housing, using appropriate thrust washers. Assemble differential side gear to ring gear and assemble ring gear to differential housing, using new bolts. Clamp assembly in soft jawed vise and tighten ring gear-to-differential housing bolts. Press new bearings onto differential assembly and oil bearings with plenty of Esso Extra Motor Oil 20 W 30/40.

NOTE - Dimples on thrust washer should face gear.

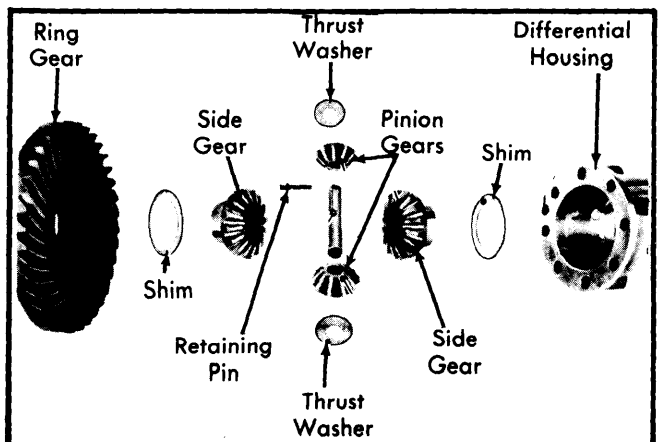

Fig. 15 Exploded View of Differential Case Components

PEUGEOT SPLIT HOUSING (I.R.S.) (Cont.)

13) With front housing held by holding fixture, place holding fixture in vise (as illustrated). Coat machined surfaces with gasket adhesive. Apply oil to bearing recesses. Install differential assembly. Install rear housing cover by means of four nuts with new washers and tighten nuts. Install bearing left side plate with new bolts and washers. Tighten bolts. Loosen four nuts on rear cover and retighten by hand.

14) Now clamp assembly in vise with right side facing upward. Install special tool (clamp) P and hand tighten only. Rotate pinion spline five turns in both directions and recheck tightness of clamp P and retighten rear cover nuts.

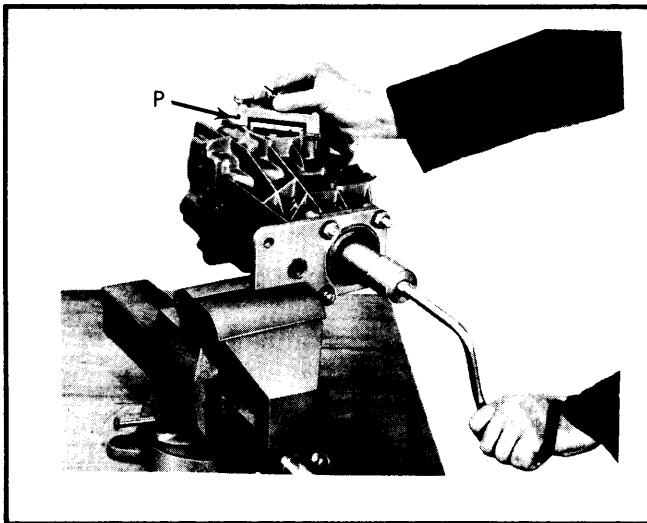

Fig. 16 Installing Special Tension Tool on Right Side

15) Move assembly in vise to its normal upright position. Install backlash measuring tool R horizontally making sure that one of the radial grooves in ring gear face is in line with double quotation mark " " of device. Lock central screw and install support rod Q2 in front upper housing. Mount dial indicator using holder Q3 so that dial indicator feeler (foot) is resting between two marks found on flat side of tool R and so that feeler (foot) and tool R form a right angle. Turn pinion carefully clockwise to set dial indicator small hand to "5". Adjust dial indicator face to "0" while applying upward pressure on arm 1. See Fig. 17.

NOTE — Before taking each reading, make sure dial indicator has been set to zero.

16) Press downward on arm 1 until it abuts. In this position dial indicator reads backlash between drive pinion and ring gear. Note the reading and repeat this operation at the three different gaps in tool R. Write down the two extreme readings. If difference between maximum and minimum reading exceeds .10 mm, check for dirt or burrs on teeth. Subtract minimum from maximum to determine thickness of shims to be installed on left-hand side under side thrust plate.

17) Remove backlash measuring tool and clamp tool P. Place indicated shims into housing on bearing outer race, install new "O" ring and thrust plate with new oil seal. Install four bolts

which retain this plate to housing. Reinstall assembly into vise with right side up. Hand tighten central screw on tool P, while turning drive pinion.

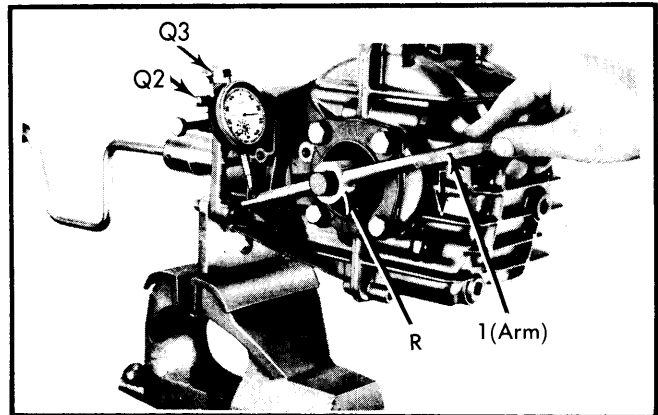

Fig. 17 Measuring Ring-to-Pinion Gear Backlash

18) Place tool KZ on flat surface of right hand front housing with dial indicator long feeler (foot) resting on outer bearing race. Make sure dial indicator does not rest on both front and rear housings, only on front or rear. Adjust dial indicator to obtain 1.00 mm on hand and zero dial face. Remove dial indicator and place on machined surface to determine difference in two readings, which indicates depth of outer race. To obtain correct calculation, add .25 mm to difference (between dial indicator reading and preset depth of 1.0 mm). See sample calculation.

NOTE — Do not forget to subtract 1.0 mm upon which dial indicator was zeroed.

Sample Calculation

Measurement On Machined Surface	7.15 mm
Measurement In Housing	-1.00 mm
Difference Between These	6.15 mm
Constant To Be Added	+ .25 mm
Total	6.40 mm

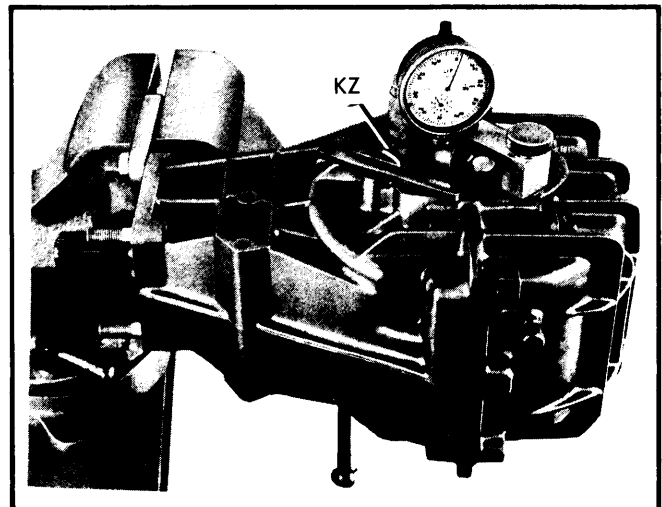

Fig. 18 Installing Tool for Measuring Side Cover Shim Thickness

PEUGEOT SPLIT HOUSING (I.R.S.) (Cont.)

19) Place dial indicator on right-hand side plate with dial indicator feeler (foot) on outside machined surface (see illustration). Adjust dial indicator to obtain reading of "1.00" and zero face. Place dial indicator on machined surface and note reading.

NOTE — Displacement of needle represents height of collar on plate. To calculate height, see sample calculation.

Sample Calculation

Measurement On Machined Surface	7.29 mm
Dial Indicator Reading Before Zeroing	- 1.00 mm
Height Of Collar (Total)	6.29 mm

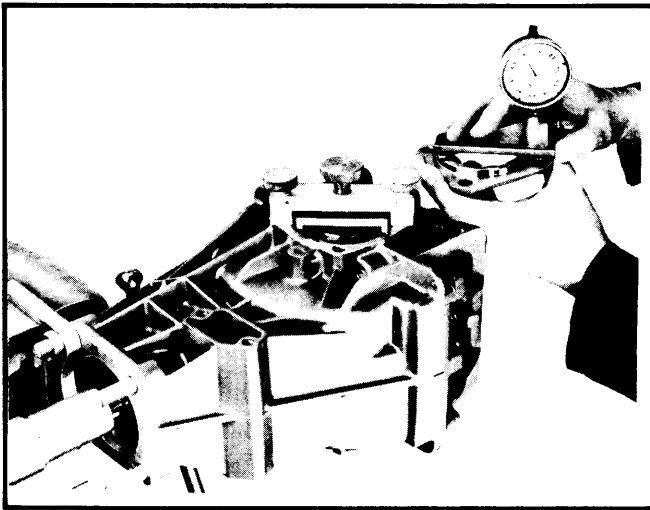

Fig. 19 Measuring Depth of Side Cover

20) Subtract number obtained in step 19) from number obtained in step 18). The resulting number is correct thickness of shims to be placed between outer bearing race and side cover. Install shims and side plate. Tighten bolts.

NOTE — Shims are available in thickness increments of .10 mm.

21) Refer to steps 15) through 17) to determine and compensate for backlash. Install necessary shims and tighten side cover bolts. Install assembly into vehicle as previously outlined.

REAR DRIVE AXLES

Disassembly — 1) With drive axles removed as previously outlined and hub assemblies removed from axles (also previously outlined), clamp drive axle vertically in soft jawed vise. Place adhesive tape on oil seal bearing surface. Using suitable pliers, uncrimp upper edge of metal cover (see illustration). Using soft faced hammer, gently tap downward on cover to uncover constant velocity joint. Place adhesive tape around CV joint.

NOTE — Constant velocity joint is not repairable and must be replaced as a unit.

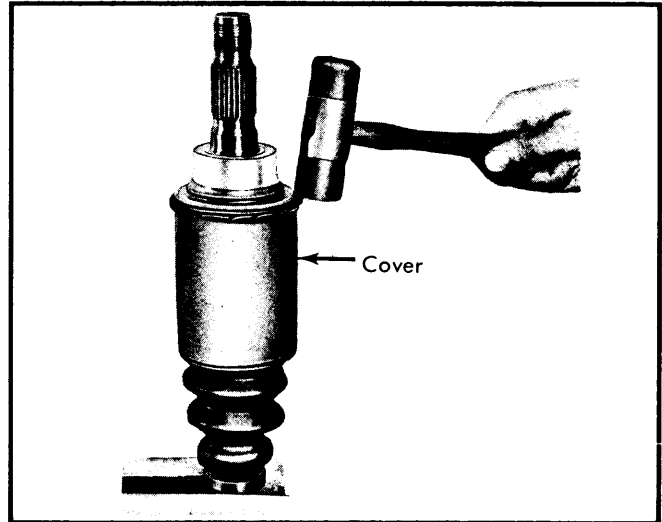

Fig. 20 Removing Protective Cover from Axle Assembly

2) Remove as much grease as possible, but do not dip components in degreasing agent. Use press to remove constant velocity joint.

NOTE — There is no need to remove three punch marks on end of shaft as they will disappear during removal procedure.

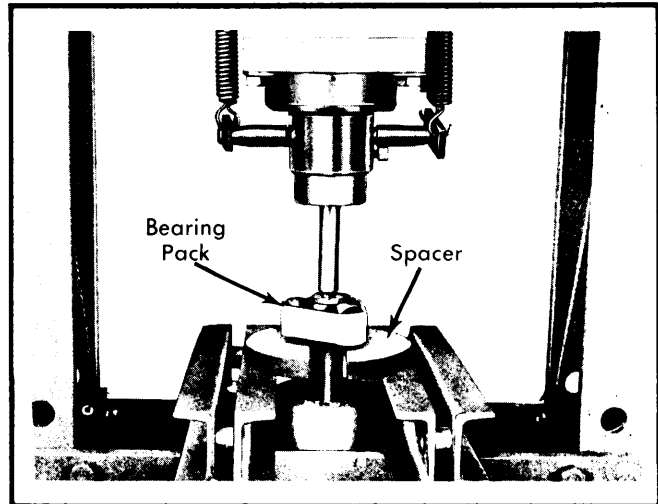

Fig. 21 Removing Constant Velocity Joint

3) Remove protective cover (metal) and rubber ring. Remove other "U" joint in same manner as previously described. From outside of CV joint housing, remove "O" ring. From inside, remove all grease. If nylon bushing on inside of CV joint housing is damaged, remove nylon with chisel.

4) Remove retaining washer with screwdriver. Use small stone and drill to remove any burrs in housing. When this operation is complete, clean inside of housing and blow dry with compressed air.

Reassembly — 1) To reassemble, reverse disassembly procedure with the following precautions:

PEUGEOT SPLIT HOUSING (I.R.S.) (Cont.)

2) When reinstalling metal covers, note there are two different sizes. The shorter one fits on the wheel side of the shaft. After installing constant velocity joints onto their respective shafts, use punch to peen shaft at three equidistant places on end of shaft.

3) If nylon bushing (stop) was removed, insert new bushing (stop), then insert washer over bushing and peen washer in three equidistant places. Before installing cover over CV joint housing, grease inside of housing and replace "O" ring. With cover over housing and assembly placed in press to hold tension, peen over cover. Install axle assembly as previously outlined.

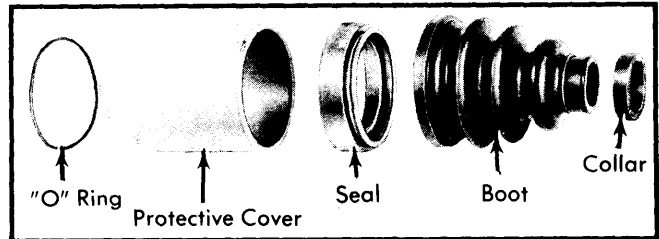

Fig. 23 Protective Covers for Installation on Axle Assembly

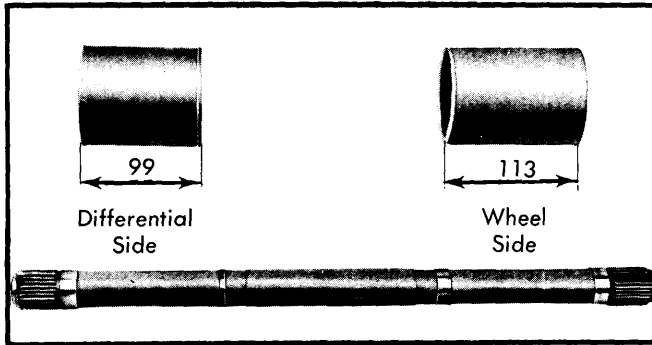

Fig. 22 Protective Axle Joint Cover Positioning

TIGHTENING SPECIFICATIONS

Application	Ft. Lbs. (mkg)
Hub Carrier-to-Lower Control Arm.....	29.0 (4.0)
Rear Caliper Retaining Bolts	31.0 (4.25)
Rear Hub Nut.....	189.0 (25.0)
Rear Lug Nuts	43.5 (6.0)
Differential Housing-to-Sub-Frame (Allen).....	27.1 (3.75)
Rear Brake Pad Retaining Fork Bolt	13.0 (1.75)
Drain & Fill Plugs	20.0 (2.75)
Ring Gear-to-Differential Assembly.....	51.0 (7.0)
Differential Side Plate Bolts.....	5.8 (.8)
Propeller Shaft (Torque) Tube Nuts	43.5 (6.0)