

COURIER

Courier

DESCRIPTION

This axle assembly incorporates a removable carrier differential, having a hypoid type ring and pinion gear set, with the pinion being retained in the carrier by a companion flange and nut. Semi-floating axles are secured in the housing by the axle shaft bearing retainers.

AXLE RATIO & IDENTIFICATION

Only one type of axle assembly is used. Axle ratio is 3.63:1 for all models. This can be determined by dividing the number of teeth on ring gear by the number of teeth on pinion gear.

REMOVAL & INSTALLATION

AXLE SHAFTS & BEARINGS

Removal — After removing complete brake assembly, including nuts securing backing plate and bearing housing-to-axle housing, slide axle shaft out of housing. Remove inner oil seal from axle shaft, spread locking tabs on lock washer, then using a suitable spanner (T72J-4252) remove lock nut and

washer. Using a suitable puller (T72J-1225), remove bearing with housing from shaft. Remove bearing cup and outer seal from bearing housing.

Installation — 1) Using suitable tool (T72J-1177), install new outer seal in bearing housing. Press or drive new bearing cup into retainer using tool (T72J-4252-B). Install brake backing plate and bearing housing on axle shaft, then position bearing on axle shaft.

NOTE — Ensure bearing taper points in right direction.

2) Slide tool (T72J-4252-A) over shaft. Place axle shaft on end in press. Press bearing in place. Install lock washer and nut, using spanner to tighten nut.

3) Install axle shaft and loosely assemble 2 bolts through bearing housing and axle housing flange. Mount dial indicator to backing plate so axle end play can be measured.

4) If end play is not to specification, adjustment is made by using appropriate shims between axle housing flange and bearing housing. After correct end play is obtained, install and tighten as necessary, all remaining components.

NOTE — If both axles have been removed, check end play of each shaft as it is installed.

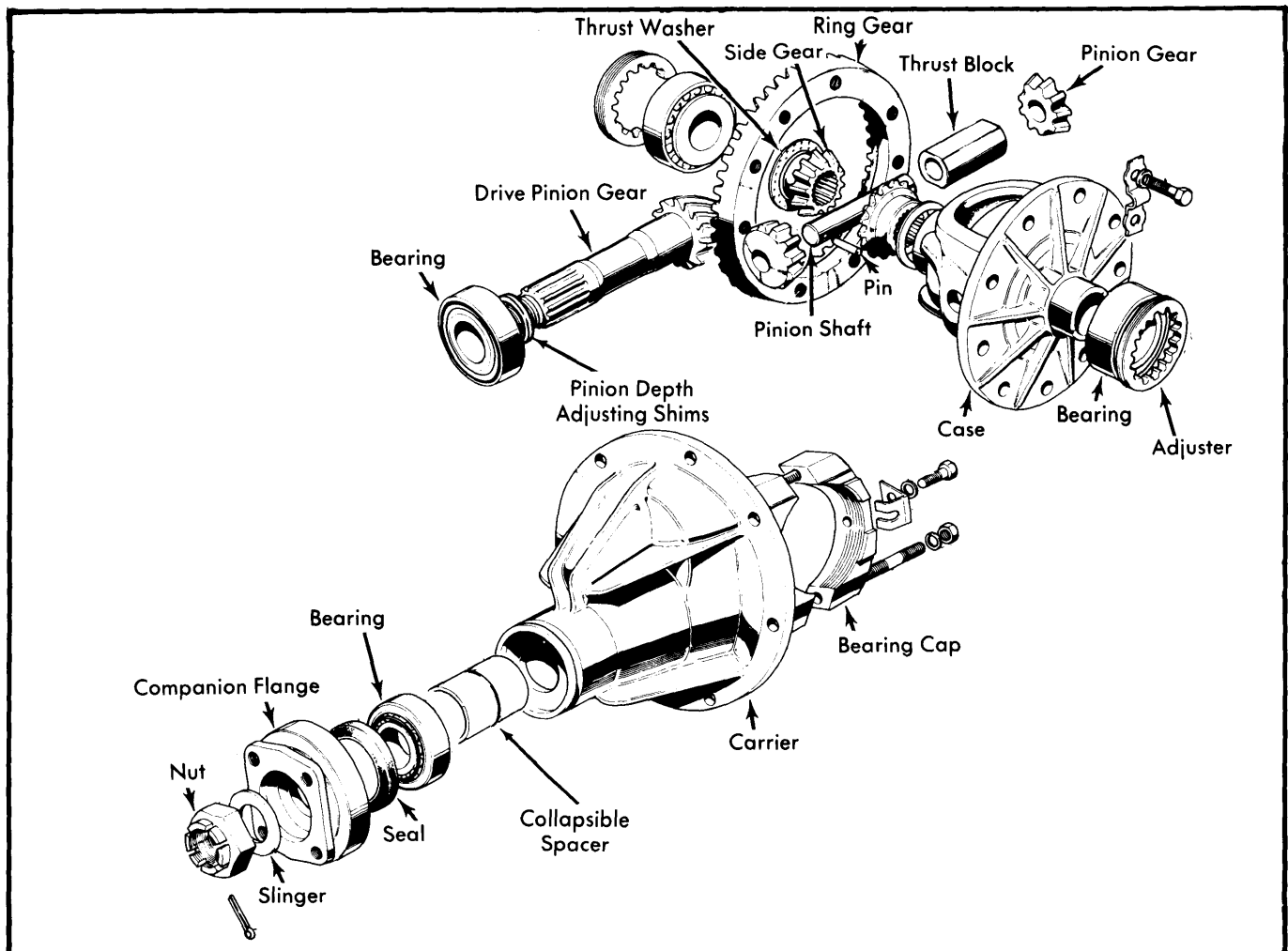

Fig. 1 Exploded View of Courier Differential Assembly

COURIER (Cont.)

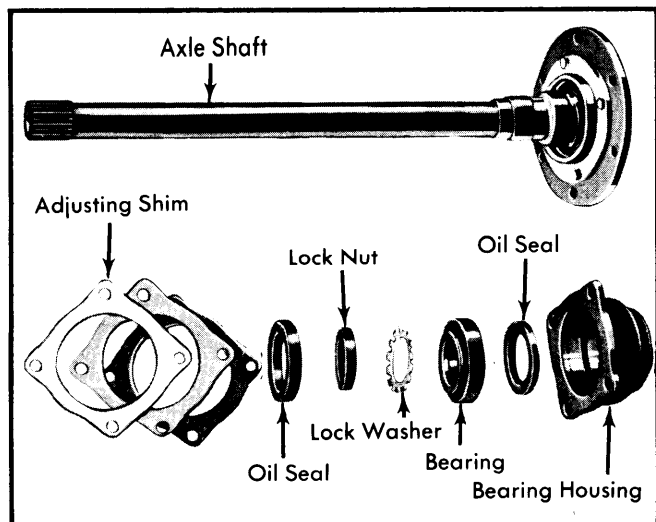

Fig. 2 Exploded View of Axle Assembly

DIFFERENTIAL CARRIER

Removal — Raise and support vehicle. Drain lubricant from differential, replace drain plug, then remove axle shafts as previously outlined. Mark drive shaft and companion flange at differential for reference at time of reassembly, then remove drive shaft. Remove carrier-to-housing retaining nuts, then remove carrier from housing.

Installation — Reverse removal procedure using a suitable sealer between the carrier and axle housing, and insure the drive shaft-to-companion flange reference marks are aligned.

OVERHAUL

DISASSEMBLY

1) Remove differential carrier as previously outlined, then mount carrier assembly in a suitable holding fixture with ring gear facing upward. Mount a dial indicator to carrier housing and check ring gear runout for reference at time of reassembly. Also make a gear tooth contact pattern check. Refer to Rear Axle Gear Tooth Patterns in this section.

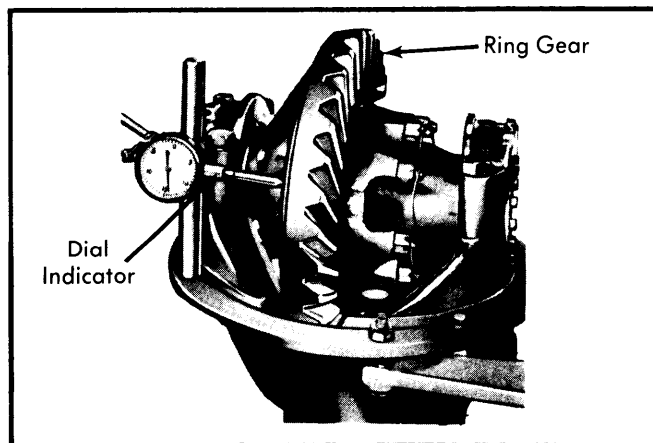

Fig. 3 Checking Ring Gear Backface Runout

2) Punch mark differential bearing caps and adjusters for reference at time of reassembly. Remove adjuster lock plates. Loosen bearing cap nuts and back off adjusters using suitable spanner (T72J-4067). Remove nuts, bearing caps and adjusters, keeping each bearing cap with its own adjuster.

NOTE — Left adjuster has left hand threads.

3) Lift out differential assembly keeping each bearing outer race with its own bearing. To remove differential bearings, use a suitable puller (T70P-4221). Remove bolts and locks retaining ring gear to case, then remove ring gear. Drive out differential pinion shaft lock pin and remove pinion shaft and thrust block. Rotate pinion gears 90 degrees and remove them. Lift out differential side gears along with their thrust washers.

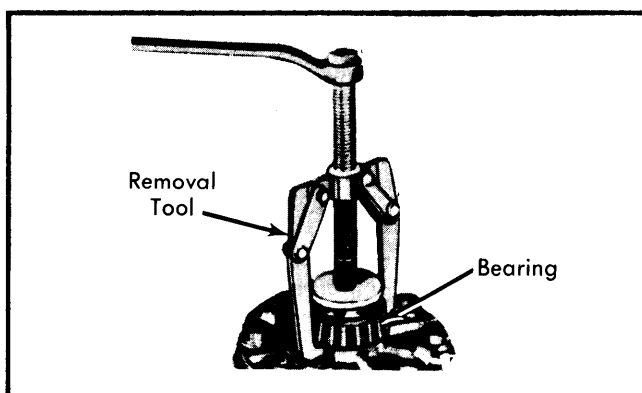

Fig. 4 Removing Differential Bearings

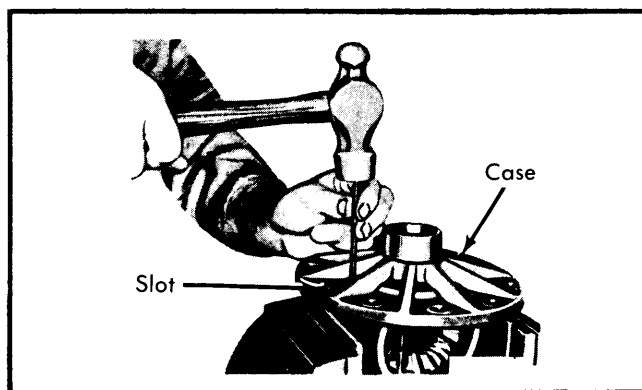

Fig. 5 Removing Pinion Shaft Lock Pin

CAUTION — If required, use soft headed mallet to tap pinion gear from case and guide pinion out to avoid damage to gear teeth.

4) Hold pinion gear companion flange and remove nut, then flange. Remove drive pinion and rear bearing. Remove collapsible spacer, oil seal and front bearing. Remove pinion bearing races from carrier using a drift in the slots provided. Remove bearing from pinion gear using suitable tool (T72J-4630) and remove pinion gear shim.

REASSEMBLY & ADJUSTMENT

Case Assembly — 1) If original ring and pinion gear set is being installed, use original shim between bearing and pinion head. If a new gear set is being installed, determine the size of shim to use in the following manner: Drive pinions may be stamped either "+ 1,2,3" or "- 1,2,3", or they may be unmarked. Compare marks on tapered ends of old and new

COURIER (Cont.)

gears. Subtract the two numbers. A plus remainder means to install a **thinner** shim than the original. A minus remainder means to install a **thicker** shim than the original. If the number is the same on both gears or if both gears are unmarked, use the original shim.

NOTE — Shims are available in thicknesses from .120" to .135" (3.048 mm to 3.429 mm) in increments of .001" (.025 mm).

2) Using suitable driver (T72J-4616-A) install pinion gear bearing races. Install selected shim on pinion gear then install bearing on pinion using suitable tool and a press. Install pinion gear and bearing in carrier followed by the collapsible spacer, front bearing, oil seal and companion flange nut.

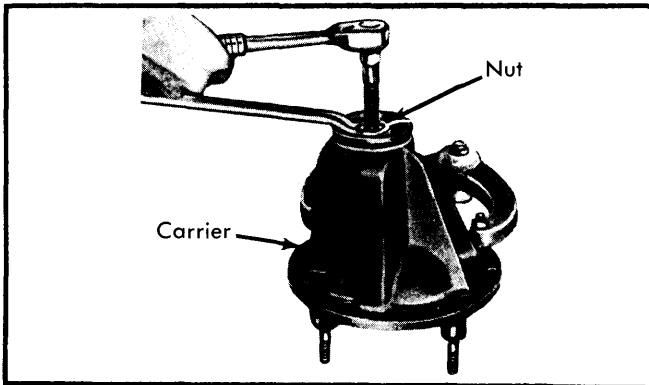

Fig. 6 Installing Drive Pinion Bearing Races

3) Using an inch pound torque wrench on companion flange nut, rotate pinion gear and note drag of oil seal. Remove inch pound torque wrench and start tightening nut. As nut is tightened, keep checking rotating torque with inch pound torque wrench. Preload is correct when nut is tightened to 145 ft. lbs. (20 mkg) minimum, and rotating torque is 11.3-15.6 INCH lbs. (13-18 cmkg) plus the oil seal drag.

NOTE — If preload is exceeded, install new collapsible spacer and repeat procedure. Do not back-off nut to obtain preload.

Differential Assembly — Reverse disassembly procedure noting the following checks and adjustments.

Side-to-Pinion Gear Backlash — After installing side and pinion gears, insert pinion shaft, without thrust block, into its proper position. Check side-to-pinion gear backlash. If backlash exceeds .008" (.20 mm), refer to table and install appropriate side gear thrust washers to obtain the correct backlash. Remove pinion shaft, then reinstall it with the thrust block.

Side Gear Thrust Washers	
I.D. Mark	Thickness
6063" (1.6 mm)
7067" (1.7 mm)
8071" (1.8 mm)

Ring-to-Drive Pinion Gear Backlash — After differential is completely assembled and installed in carrier, snug bearing cap nuts. Turn adjusters, using spanner, until bearings are properly seated and end play is eliminated with a slight amount of ring-to-drive pinion gear backlash. Slightly tighten one bearing cap nut on each side. Mount dial indicator to carrier flange with indicator plunger set at a right angle to

ring gear teeth. Check ring-to-drive pinion gear backlash at four or five points around ring gear. Turn both adjusters equally to obtain specified backlash. Proceed by setting differential bearing preload.

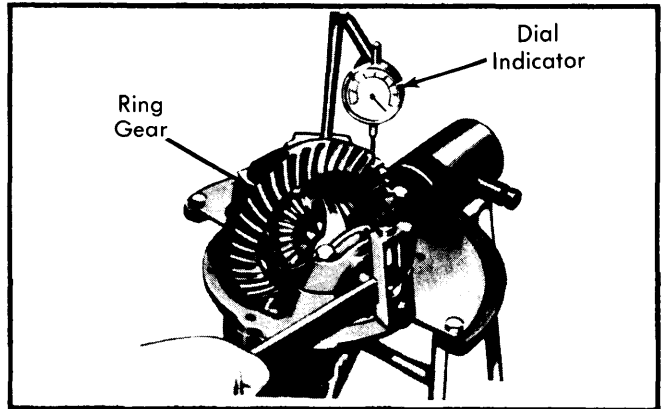

Fig. 7 Checking Ring-to-Pinion Gear Backlash

Differential Bearing Preload — Taking care not to disturb ring-to-drive pinion gear backlash, set preload using a dial indicator as shown in illustration. After setting preload, tighten bearing cap nuts and complete assembly procedure.

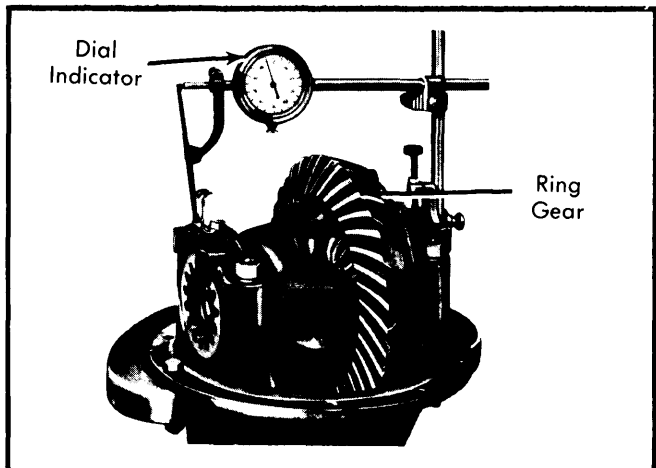

Fig. 8 Checking Differential Bearing Preload

AXLE ASSEMBLY SPECIFICATIONS

Application	Specification
Axle Shaft End Play [Ⓛ]002-.004" (.05-.10 mm)
Ring-to-Pinion Gear Backlash..	.0075-.0083" (.19-.21 mm)
Ring Gear Backface Runout (Max.)003" (.08 mm)
Differential Bearing Preload0045" (.11 mm)

[Ⓛ] — If both shafts were removed, end play of first shaft installed should be .026-.033" (.65-.82 mm).

TIGHTENING SPECIFICATIONS

Application	Ft. Lbs. (mkg)
Differential Bearing Cap Nuts	40.5-49.5 (5.6-6.8)
Carrier-to-Axle Housing Nuts	11.5-17.0 (1.6-2.35)
Axle Shaft Bearing Retainer Bolts	12-16 (1.7-2.2)
Ring Gear-to-Case Bolts	39.5-47.0 (5.4-6.5)
Companion Flange Nut	145-250 (20-34.5)