

## TOYOTA LAND CRUISER

FJ40 Series  
FJ55 Series

### DESCRIPTION

Clutch is dry, single plate, coil spring type. Clutch actuation is hydraulic, using a master cylinder mounted at pedal bracket on firewall and a slave cylinder attached to the engine mounting rear bracket. A prelubricated clutch release bearing is also used.

### REMOVAL & INSTALLATION

#### CLUTCH ASSEMBLY

**Removal** – 1) Remove protective cover under transmission, and disconnect front and rear drive shafts from transfer case. Drain lubricant from transmission and transfer case. Disconnect parking brake cable from link lever. On FJ40 Series, drain fuel tank.

2) On FJ40 Series only, remove front seats, seat frames and console. Separate rear heater line clamp from tunnel. Remove fuel tank cover and fuel tank. On all series, remove shift lever boot and shift lever. Remove transmission cover.

3) Disconnect all electrical wires and vacuum lines from transfer case and transmission. Support transmission/transfer case assembly and remove mounting bolts.

4) Disconnect clutch fork return spring and remove slave cylinder, but do not disconnect hydraulic line unless necessary. Remove release bearing retaining clips, and release bearing with collar. Remove clutch lever assembly.

5) Mark pressure plate and flywheel for reassembly reference. Loosen clutch attaching bolts one turn at a time until spring pressure is released, then remove bolts and clutch assembly

**Installation** – To install, reverse removal procedure and note the following: Use suitable aligning tool to center disc on flywheel. Tighten clutch attaching bolts alternately and evenly. After reinstallation, adjust clutch fork free play and bleed hydraulic system if necessary.

#### CLUTCH MASTER CYLINDER

**Removal** – Remove clevis pin connecting master cylinder push rod to clutch pedal. Disconnect hydraulic line from cylinder body and plug opening. Remove cylinder attaching bolts at firewall and remove master cylinder.

**CAUTION** – Do not allow fluid to spill on painted surfaces.

**Installation** – To install, reverse removal procedure, adjust pedal height and clutch pedal free play, and bleed hydraulic system. Check hydraulic system for leaks.

#### CLUTCH SLAVE CYLINDER

**Removal** – Plug master cylinder reservoir cap. Disconnect clutch return spring from hanger. Disconnect flexible hose from metal line and remove clip. Remove slave cylinder retaining bolts and remove slave cylinder.

**Installation** – To install, reverse removal procedure, adjust clutch fork free play and bleed hydraulic system.

#### CLUTCH RELEASE BEARING

**Removal & Installation** – With clutch assembly removed, remove release bearing from hub with suitable bearing remover/installer (0931500021). To install bearing, lubricate with multi-purpose grease and seat bearing with the remover/installer.

#### PILOT BEARING

**Removal & Installation** – With clutch assembly removed, check pilot bearing in end of crankshaft for roughness or noise during rotation. If defective, remove using a suitable puller (0930355011). To install, lubricate bearing with multi-purpose grease and insert into crankshaft using suitable driver (0930447010).

### OVERHAUL

#### CLUTCH MASTER CYLINDER

**Disassembly** – Remove reservoir cap, drain fluid, and remove float. Remove reservoir and rubber boot from cylinder body. Remove snap ring, push rod, piston stop plate and boot. Remove piston and return spring from cylinder, then remove cylinder cup from piston. Clamp cylinder cap in a vise and, using a pipe wrench on cylinder body, remove body from cap. Remove cylinder cup spacer from cylinder.

**Cleaning & Inspection** – Wash all parts in clean brake fluid and inspect for wear or damage. If master cylinder bore-to-piston clearance exceeds .006" (.15 mm), replace defective part. Replace piston cups during overhaul.

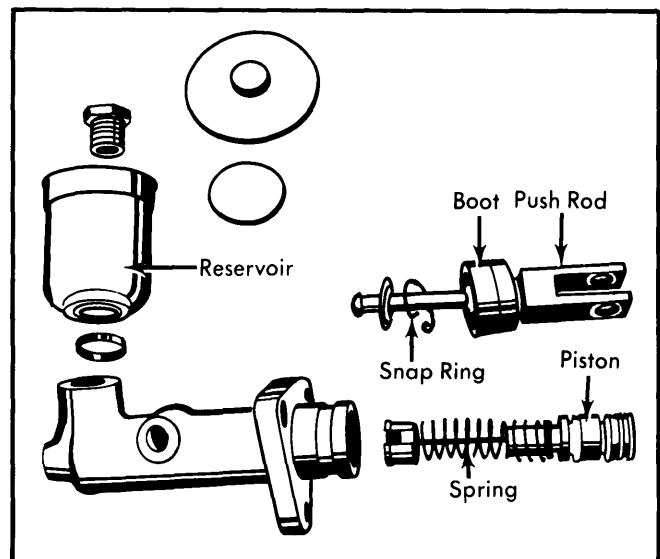

Fig. 1 Exploded View of Clutch Master Cylinder

**Reassembly** – Soak all parts in clean brake fluid before reassembly. Install piston stop plate, push rod, boot and snap ring into body.

## TOYOTA LAND CRUISER (Cont.)

2) Install a new cylinder cup onto piston, and insert piston into cylinder through front of bore. Install cup spacer and cylinder cup into cylinder bore. Install return spring with spring seat into cylinder and onto piston, then install cylinder cap with a new gasket.

3) Install reservoir onto master cylinder, install bolt and washer and tighten securely. Install float into fluid reservoir, and install reservoir cap.

### CLUTCH SLAVE CYLINDER

**Disassembly** — Remove push rod assembly and rubber boot from cylinder body. Withdraw cylinder piston and cup seal. Loosen and remove bleeder screw.

**Cleaning & Inspection** — Wash all parts in clean brake fluid and inspect for wear or damage. If slave cylinder bore-to-piston clearance exceeds .006" (.15 mm), replace defective part. Replace piston cups during overhaul.

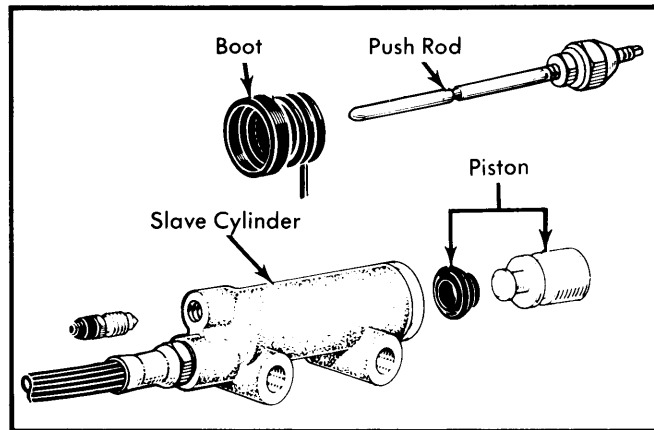

Fig. 2 Exploded View of Clutch Slave Cylinder

**Reassembly** — Soak all parts in clean brake fluid before reassembly. Reverse disassembly procedure and install boot with protruded part down.

### ADJUSTMENT

#### PEDAL HEIGHT

Pedal height is measured from floor (asphalt sheet) to top of pedal pad. To adjust, loosen lock nut and push rod. Rotate stop bolt until pedal height is as specified in chart.

Application	Pedal Height	Height
FJ40 Series		
With Power Brake Unit .....	8.47"	(215 mm)
Without Power Brake Unit .....	7.80"	(198 mm)
FJ55 Series		
With Power Brake Unit .....	7.28"	(185 mm)
Without Power Brake Unit .....	6.77"	(172 mm)

#### PEDAL FREE PLAY

Clutch pedal free play is that distance of free movement before master cylinder push rod contacts piston. To adjust, loosen lock nut and turn push rod to obtain .02-.12" (.5-3.0 mm) free play. Tighten lock nut.

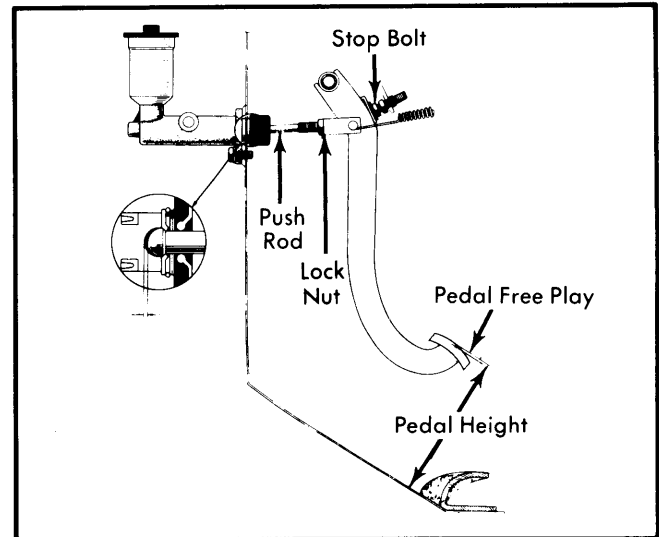

Fig. 3 Pedal Height Measuring and Adjustment Points

#### CLUTCH FORK FREE PLAY

To adjust clutch fork free play, loosen lock nut at slave cylinder and turn push rod tip while holding push rod nut with suitable wrench. Free play should be .12-.16" (3-4 mm). Tighten lock nut and check clutch pedal free play.

#### HYDRAULIC SYSTEM BLEEDING

- 1) Connect a flexible tube to slave cylinder bleeder screw, and place opposite end in a container partially filled with brake fluid.
- 2) Pump clutch pedal several times. With pedal depressed, loosen bleeder screw one-third to one-half turn and allow air to bleed out. Tighten bleeder screw.
- 3) Continue operation until air bubbles are no longer seen in fluid being discharged into container. Tighten bleeder screw securely and install cap. Check fluid level in master cylinder reservoir, and check system for leaks.

### TIGHTENING SPECIFICATIONS

Application	Ft. Lbs. (mkg)
Engine-to-Clutch Housing .....	36-58 (5.0-8.0)
Pressure Plate-to-Flywheel .....	11-16 (1.5-2.2)
Reservoir .....	15-22 (2.0-3.0)