

AUDI FOX

Fox

DESCRIPTION

Clutch is single plate dry disc type, using a diaphragm type pressure plate and a pre-lubricated clutch release bearing. Clutch is cable actuated.

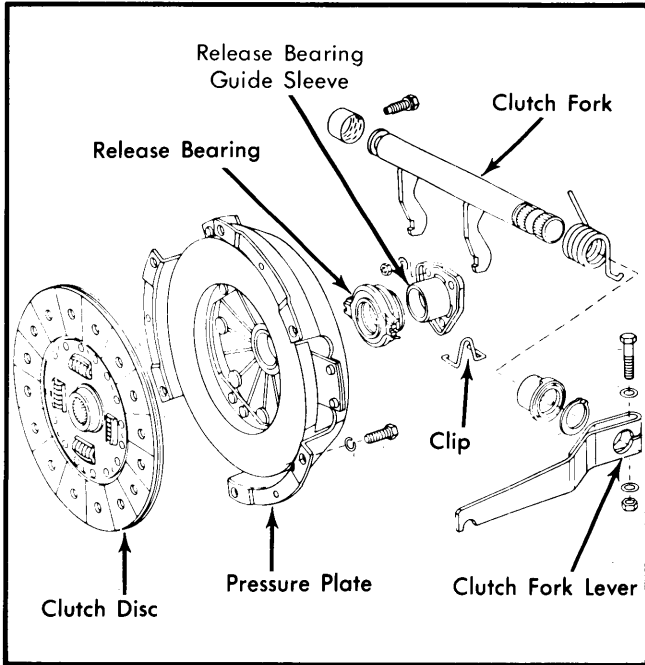

Fig. 1 Exploded View of Clutch Assembly

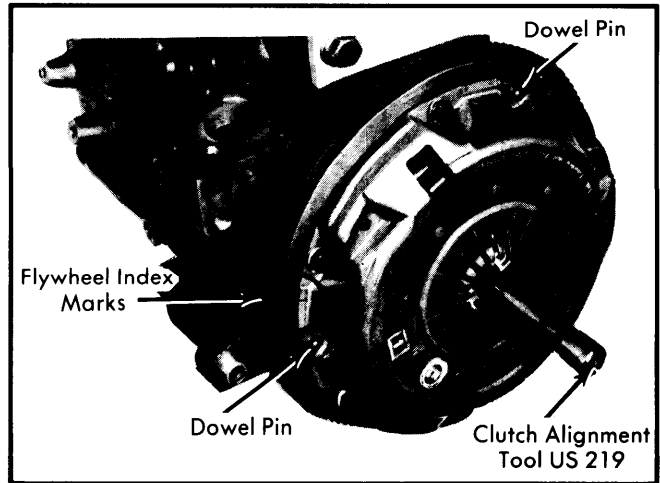

Fig. 2 Aligning Clutch Assembly Reference Marks for Reinstallation

REMOVAL & INSTALLATION

CLUTCH ASSEMBLY

Removal — 1) Disconnect negative battery cable. Disconnect exhaust header pipe at manifold and bracket on transmission.

2) Remove bolt mounting shift assembly coupling to rear of transmission shifting shaft and separate assemblies. Unhook clutch cable at release lever. Disconnect speedometer.

3) Disconnect axle drive shafts at inner drive flanges. Remove starter. Take out front clutch housing cover plate. Remove transmission-to-engine mounting bolts.

4) Suitably support transmission with jack. Remove transmission rear mounts and brackets. Pry transmission away from engine and slide it out of vehicle.

5) Install holding tool (10-201) to flywheel and index (mark) pressure plate and flywheel. Loosen pressure plate bolts $\frac{1}{4}$ turn at a time in a diagonal pattern. Slide pressure plate off flywheel dowels and separate clutch disc.

Installation — To install, reverse removal procedure and note: Use clutch alignment tool to fit pressure plate and clutch. Make sure alignment marks are observed.

CLUTCH RELEASE BEARING

- 1) With transmission separated from engine, remove spring clips securing release bearing to clutch fork. Bearing is pre-lubricated; do not wash in any cleaning solution.
- 2) Rotate bearing and check for roughness or noise, replace as necessary. Apply Molykote paste to bearing contact points on clutch fork. To install, reverse removal procedure.

PILOT BEARING

Lock flywheel to prevent rotation. Install suitable remover (10-202) and remove pilot bearing. Install bearing with suitable installer (VW207C) and seat bearing until distance from flywheel recess to bushing edge is $\frac{1}{16}$ " (1.5 mm). Lubricate bearing.

ADJUSTMENT

CLUTCH PEDAL FREE PLAY

To obtain correct free play between clutch release bearing and clutch, clutch pedal free play must be correct. Free play can be adjusted by loosening and adjusting both counternuts at clutch cable to obtain .590" (15 mm) free play at pedal.

TIGHTENING SPECIFICATIONS

Application	Ft. Lbs. (mkg)
Clutch Assembly-to-Flywheel.....	18 (2.5)
Transmission-to-Engine	40 (5.5)
Clutch Lever-to-Transmission.....	12-18 (1.7-2.5)
Drive Shaft-to-Transmission	25.5 (3.5)