

240 SERIES 4 CYLINDER

ENGINE CODING

ENGINE IDENTIFICATION

Engine identification number is located on camshaft timing belt cover. Last 3 digits identify engine.

Engine Identification Numbers		
Application	Man. Trans.	Auto. Trans.
B21F Engines		
Federal	498780	498781
Calif.	498782	498783

ENGINE, CYLINDER HEAD & MANIFOLD

ENGINE

- 1) Disconnect rubber boot and lock ring at base of gearshift lever (manual transmission). Remove battery. Disconnect windshield washer hose and engine compartment lamp. Remove hood.
- 2) Remove cap from expansion tank. Open radiator drain cock and drain coolant. Disconnect lower radiator hose at radiator, crankcase ventilation hose at cylinder head, and upper radiator hose at engine. Detach expansion tank hoses from radiator. Disconnect oil cooler pipes for automatic transmission at radiator. Remove fan shroud screws, disconnect radiator, and lift radiator and fan shroud from car.
- 3) Remove air cleaner and hose assembly. Loosen tensioner nut and remove belt from air pump. Disconnect hoses at pump and remove pump and bracket assembly. Remove vacuum pump after disconnecting hoses, including hose to brake power cylinder. Remove tensioner bar bolts, drive belt and power steering pump.
- 4) If equipped with air conditioning, remove crankshaft pulley and A/C drive belt. Reinstall pulley loosely. Disconnect and remove compressor and bracket.
- 5) Mark and disconnect four vacuum hoses at engine and two carbon filter hoses. Remove wire or connector from distributor, high tension lead from coil, and starter motor cables and clutch cable clamp from starter.
- 6) Detach wiring harness from voltage regulator. Disconnect throttle cable at pulley and A/C wire at solenoid on intake manifold.
- 7) Remove fuel cap to relieve pressure, and remove fuel hoses from filter and return pipe. Remove guard plate for ballast resistor, and disconnect two wire connectors from intake manifold micro switch, four in wiring harness, and two at ballast resistor.
- 8) Disconnect heater hoses at firewall and drain oil from engine. Remove exhaust pipe flange nuts and gasket. Remove front engine mounting bolts and front exhaust pipe mounting

bracket. Disconnect gearshift control rod (automatic transmission) or clutch cable (manual transmission).

9) Disconnect speedometer cable, propeller shaft U-joint, and gearshift selector from control rod. If manual transmission has overdrive, disconnect wire to gearshift selector. Using a wooden block, place jack under transmission. Remove transmission support member.

10) Attach lifting yoke assembly (5035) to three engine lifting eyes, and adjust lifting beam (2810) to its rearmost position. Hoist slightly to release front engine mount dowels. Check for wires or hoses, and disconnect as necessary. Adjust lifting beam to forward position and lift engine from car.

INTAKE & EXHAUST MANIFOLDS

Removal – 1) Disconnect battery ground cable, then remove air bellows from CI unit to intake manifold. Disconnect PCV hoses at intake manifold and flame arrester. Disconnect vacuum pump hose at intake manifold. Disconnect diverter valve hoses. Disconnect air pump with tensioner and position to one side.

2) Disconnect the following fuel lines: control pressure regulator (one hose), cold start injector (one hose), distributor pipe to engine (two hoses) front fuel filter to engine (two hoses), and injector hoses (four hoses). Disconnect wiring at control pressure regulator, cold start injector, and auxiliary air valve.

3) Remove air injection pipe. Disconnect throttle cable from intake manifold. Disconnect charcoal canister hoses and EGR valve hose from intake manifold. Remove intake manifold brace, attaching nuts, and intake manifold. Disconnect transmission fill pipe from flywheel housing (automatic transmissions only). Remove attaching nuts and exhaust manifold.

Installation – To install, reverse removal procedure and use new manifold gaskets. Tighten nuts and bolts to specifications.

CYLINDER HEAD

Removal – 1) Drain cooling system at radiator and cylinder block. Disconnect battery ground cable. Disconnect upper radiator hose at engine. Disconnect air bellows between CI unit and air cleaner. Remove PCV hoses from intake manifold and oil trap on block. Disconnect vacuum pump hose at intake manifold.

2) Disconnect diverter valve hoses. Remove air pump and bracket. Disconnect the following fuel lines: control pressure regulator (one hose), cold start injector (one hose), distributor pipe to engine (two hoses), front fuel filter to engine (two hoses), and injector hoses (four hoses).

240 SERIES 4 CYLINDER (Cont.)

3) Disconnect wires at following components: control pressure regulator, cold start injector, auxiliary air valve, and temperature sender. Disconnect throttle cable from intake manifold. Disconnect charcoal canister hoses and EGR valve hose from intake manifold. Disconnect transmission fill pipe from transmission housing (automatic transmissions only).

4) Remove water pipe rear clamp from manifold. Remove exhaust manifold to exhaust pipe attaching nuts. Remove intake manifold brace. Disconnect spark plug cables at plugs, then disconnect upper water hose at firewall. Remove valve cover and cylinder head bolts. Lift cylinder head from engine.

Installation - 1) Install new head gasket with "TOP" mark upward. Be sure all contact surfaces are clean. Position cylinder head over gasket.

2) Dip head bolts and washers in engine oil before installation. Install and torque, in two steps, to specifications shown in table, and according to sequence shown in Fig. 1.

3) Adjust valves to .014-.016" (.35-.40 mm) with engine cold.

NOTE - See *Valve Clearance Adjustment* for procedure. Reverse remainder of removal procedure, and then make final valve adjustment after running engine for 10 minutes. Adjust to .016-.018" (.40-.45 mm). Retorque cylinder head bolts.

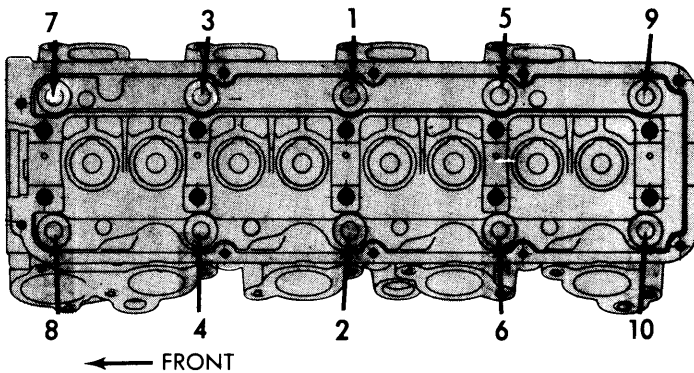

Fig. 1 Cylinder Head Tightening Sequence

Cylinder Head Tightening Specifications

Sequence	Ft.Lbs (mkg)
Step One	44 (6.0)
Step Two	①76-83 (10.5-11.5)

① - Run engine for 10 minutes until hot, allow engine to cool 30 minutes, and retorque.

CAMSHAFT

Removal - 1) Remove valve cover and gasket. Check and note markings on camshaft bearing caps. Remove center bearing cap and install holder tool (5021) to hold camshaft in place while removing remaining bearing caps.

2) Remove timing belt cover and slacken drive belt tensioner. Pull off drive belt and remove camshaft sprocket. Remove remaining bearing caps and take out front camshaft oil seal. Release screw on holder tool and lift out camshaft.

Installation - Ensure that dowel for sprocket is UP (12 o'clock position) and lubricate all bearing and friction surfaces. To complete installation, reverse removal procedure. See *INSTALLING DRIVE BELT*.

INSTALLING DRIVE BELT

1) Install belt tensioner if previously removed. Align notch in crankshaft belt guide with timing mark on front cover. Rotate intermediate shaft so timing mark on sprocket aligns with mark on belt guard. Align marks on camshaft belt guide with timing mark on valve cover.

2) New drive belts have yellow markings. Two lines should fit toward crankshaft marks and next mark toward intermediate shaft mark. Place belt over crankshaft sprocket first, then intermediate shaft. Stretch belt on tension side and fit over camshaft sprocket. Slide back of belt inside tension roller.

3) Loosen nut on belt tensioner to permit spring tension to act against drive belt. Recheck timing marks for proper location



Fig. 2 Timing Marks for Crankshaft, Intermediate Shaft and Camshaft

240 SERIES 4 CYLINDER (Cont.)

and torque nut on tensioner to 37 ft. lbs. Attach pulley to front hub on crankshaft.

VALVES

VALVE ARRANGEMENT

E-I-E-I-E-I-E-I — Front to Rear.

VALVE GUIDE SERVICING

Removal & Installation — Heat cylinder head to 140° F (60° C) and press old guides out with drift (2818). To install, use intake guide drift (5027) and exhaust guide drift (5028) to press in new guides. Press in until drift contacts cylinder head to give proper height above cylinder head. Installed height for intake guide is .610"±.004" (15.5±.1 mm) and .709"±.004" (18.0±.1 mm) for exhaust guide.

NOTE — Ensure that replacement guide is same size as old guide. At least 2000 lbs. force should be required to press in new guide; if not, head must be fitted with oversize guide.

Installation — With cylinder head heated, use drift 9995027-1 or equivalent)) to press in intake valve guide. Use drift 9995028-9 for exhaust valve guide. Press guide down until drift touches cylinder head. This establishes correct location. Force required to press in guide should be at least 2023 lbs. If force used does not reach this figure, guide seat must be reamed to nearest oversize.

VALVE SPRINGS

Removal & Installation — With cylinder head removed, compress valve springs using suitable valve spring compression tool, and remove valve retainers. Disassemble valve spring components and place valves in order in suitable valve rack. To install, place valves in position, fit valve guide seal, valve spring, upper washer and retainer.

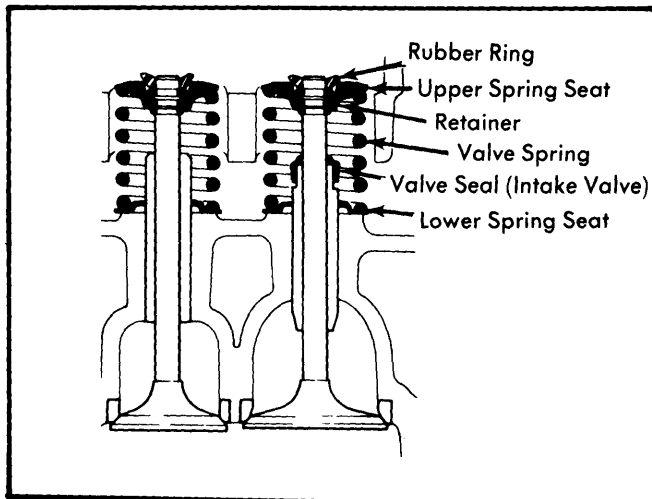

Fig. 3 Valve and Guide Assembly

VALVE SPRING INSTALLED HEIGHT

Valve spring ends must be square. Installed height of valve spring cannot exceed specifications. Measure spring height from base of spring pad on cylinder head to underside of spring retainer.

VALVE CLEARANCE ADJUSTMENT

1) Valve clearance is adjusted with engine off, and may be done either warm or cold. Remove valve cover. Turn crankshaft center bolt until camshaft is in position for firing No. 1 cylinder. Both cam lobes should point up at equally large angles. Pulley timing mark should be on 0°.

2) Using feeler gauge, check valve clearance of No. 1 cylinder, measuring between camshaft lobe and discs. Intake and exhaust valves should have same clearances:

Valve Clearances

When Checking	In. (mm)
Cold engine012-.018" (.30-.45 mm)

When Setting	In. (mm)
Cold Engine014-.016" (.35-.40 mm)
Hot Engine016-.018" (.40-.45 mm)

3) If clearance is incorrect, line up notches in valve depressors, so they are at right angles to engine center line. Install valve adjustment tool (5022) and turn handle downward until depressor groove is just above edge of cylinder head. Remove adjusting disc with special pliers (5026).

4) Using micrometer, measure thickness of disc. Then determine proper thickness required of new disc to bring clearance within specifications. For example: Measure existing clearance and subtract correct clearance. Difference should be added to thickness of old disc to determine thickness of new disc required. Discs are available in thicknesses ranging from 3.30 to 4.50 mm in increments of .05 mm.

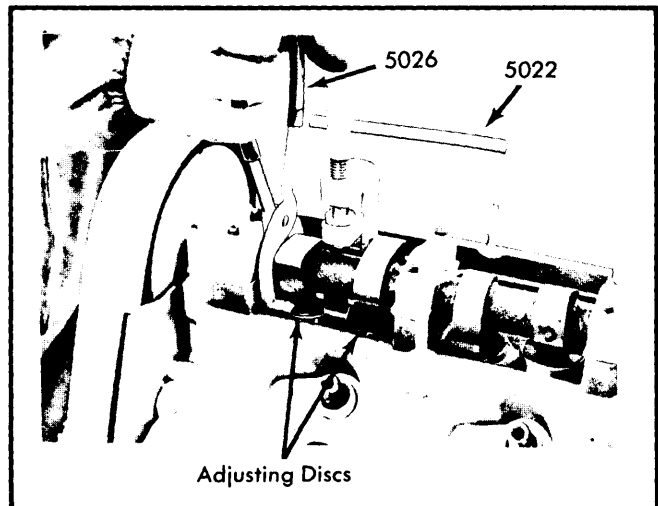

Fig. 4 Removing Valve Adjusting Discs

240 SERIES 4 CYLINDER (Cont.)

5) Discs should be oiled and installed with marks down. Remove valve adjustment tool (5022), rotate crankshaft to correct firing position for No. 3 cylinder and repeat procedure. Then adjust valve clearance for No. 4 and No. 2 cylinders. When all four cylinders have been adjusted, turn camshaft a few turns and recheck valve clearance at all cylinders.

6) Position gasket on cylinder head and install valve cover.

PISTONS, PINS & RINGS

OIL PAN

Removal — Position lifting tools (5006, 5033 & 5115) as shown in Fig. 4. Disconnect A/C compressor (if equipped). Remove bolts from left engine mount. Lift engine slightly and drain oil. Remove splash guard, left engine mount, and brace. Remove bolts from oil pan and tap to loosen.

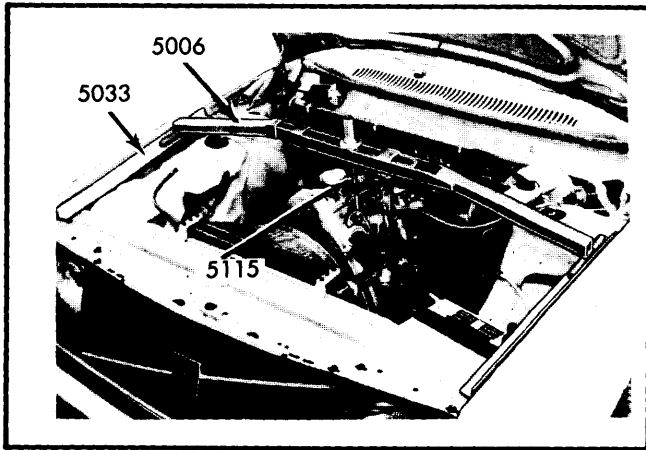

Fig. 5 Removing Oil Pan

Installation — Place new gasket on oil pan. Turn and lift into position. Install bolts, brace, left engine mount, and splash guard. Lower engine and install bolts in left engine mount. Remove tools and connect A/C compressor. Fill engine with oil.

PISTON & ROD ASSEMBLY

Removal — Remove cylinder head, oil pan and oil pump. Be sure connecting rods and caps are properly marked, so they may be reinstalled in original location. Remove carbon ridge from cylinder bores. Remove rod cap, and using wooden hammer handle, push piston out top of cylinder bore. Reinstall rod cap on piston and rod from which removed.

Installation — 1) Remove rod cap from connecting rod. Secure piston pin with retaining rings. Be sure "TOP" mark on rings is facing top of piston and end gaps are 120 degrees from each other and rings are properly installed. Install bearings in connecting rods and caps. Lubricate cylinder bores, pistons and bearings.

2) Using piston ring compressor (5031), insert rod and piston into bore, with mark on top of piston and on connecting rod toward front of engine.

3) Using wooden hammer handle, tap lightly on top of piston. Align marks and torque end caps to 43 ft. lbs. Install oil pump, oil pan and cylinder head.

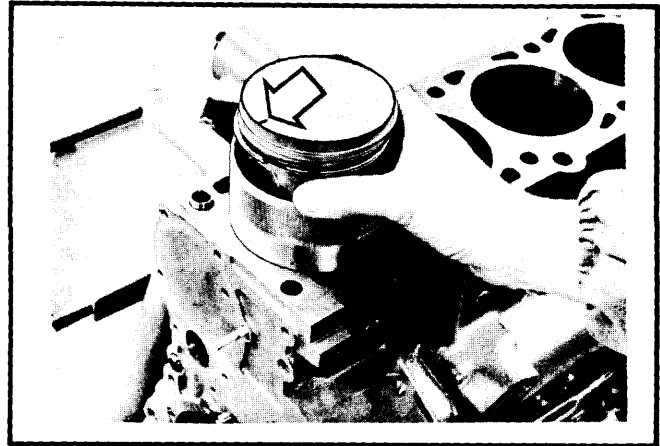

Fig. 6 Installation of Piston in Cylinder Block

FITTING PISTONS

Measure piston diameter at right angle to piston pin bore and .25" (7 mm) from lower edge. Measure cylinder bore at several positions. If difference exceeds clearance specifications, oversize pistons are available.

PISTON PINS

Piston pins are available in .002" (.05 mm) oversize from standard diameter. If replacement oversize pins are needed, piston pin hole should be reamed out to correct measurement using suitable reaming tool. Use reamer fitted with pilot guide, take only small cuts at a time. Pin fit is correct when pin can be pushed through connecting rod hole by hand, with only light resistance.

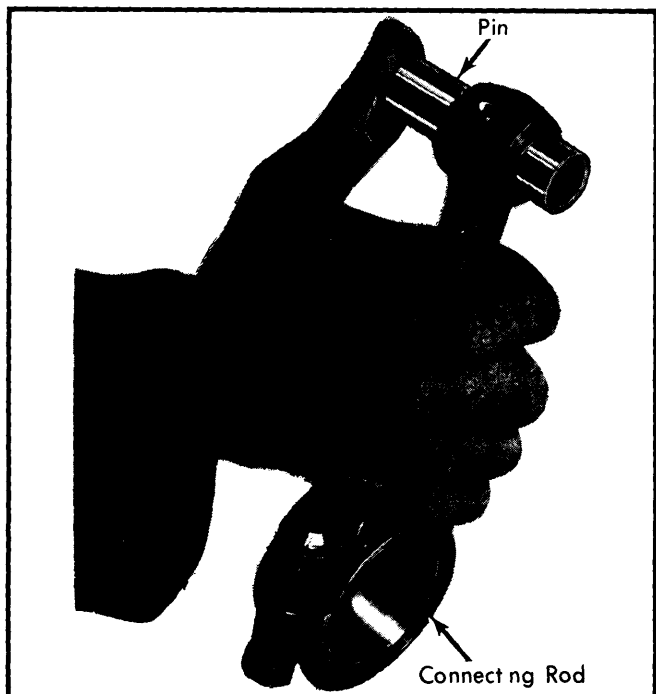

Fig. 7 Thumb Pressure Piston Fit

240 SERIES 4 CYLINDER (Cont.)

CRANKSHAFT MAIN & CONNECTING ROD BEARINGS

MAIN & CONNECTING ROD BEARINGS

Removal & Installation – 1) Remove oil pan and related parts. See *Oil Pan Removal*. Identify and mark connecting rod caps and main bearing caps to ensure correct replacement.

2) Remove connecting rod caps and push pistons towards top of cylinders. Remove main bearing caps (one at a time) and thoroughly clean all bearing surfaces.

3) Measure all journals, using a micrometer. Out-of-roundness on connecting rod bearings should not exceed .003" (.07 mm) and on main bearings, it should not exceed .002" (.05 mm). If values obtained are close to, or in excess of wear limits, crankshaft must be reground to next suitable undersize.

4) If all journals check out to standard size, refit with replacement bearings. Reinstall main bearing caps, refit connecting rods to crankshaft and tighten all nuts and bolts to specifications. Reassemble engine in reverse order of removal.

REAR MAIN BEARING OIL SEAL

Removal & Installation – 1) Remove transmission, clutch, and flywheel from engine. Remove two bolts from oil pan (into rear flange). Slacken two bolts on each side of flange, and remove flange. Use a suitable drift (2817) to remove oil seal.

2) Clean flange area thoroughly and inspect seal mating surface of crankshaft. Install new seal to flange using drift (2817). **NOTE** – If a new crankshaft has been installed, screw center bolt of tool in fully and install seal to its outer position in flange. If crankshaft has not been replaced, install seal with center bolt of tool screwed out a couple of turns.

3) Oil new seal and install flange with new gasket to cylinder block. Install attaching bolts and tighten. Install oil pan attaching bolts and tighten. Install flywheel, clutch, and transmission.

ENGINE FRONT COVER OIL SEAL

Removal – 1) Remove fan shroud, fan belt and fan pulley. Remove water pump pulley and camshaft drive belt cover. Remove crankshaft hub, sprocket and belt guide. Remove sprocket from intermediate shaft. Detach wiring harness across front of engine. Remove two oil pan bolts from base of front cover and loosen two on each side of them. Remove drive belt guard plate and front cover.

2) Using suitable tool (5025) press out intermediate shaft seal from front cover. Using similar tool (5024) press out crankshaft seal. Use same tools to install new seals.

Installation – 1) Using new gasket, install front cover. Install oil pan, drive belt guard plate, and wiring harness.

2) Using tool (5024), install crankshaft seal. Using similar tool (5025), install intermediate shaft seal in front cover. **NOTE** – Oil seals prior to installation. Install inner belt guide on camshaft (collar facing away from belt). Install camshaft

sprocket, aligning notch with dowel on camshaft. Install outer belt guide, washer and center bolt. Use suitable tool (5034) to hold sprocket and torque to 37 ft. lbs.

3) Install sprocket on intermediate shaft, aligning notch with dowel on shaft. Use tool (5034) to hold shaft while tightening center bolt to 37 ft. lbs.

4) Install belt guide and sprocket on crankshaft. Install front hub and torque center bolt to 122 ft. lbs. Install drive belt and complete installation of previously removed parts.

ENGINE OILING

Crankcase Capacity – 4 qts. including filter.

Oil Filter – Full-flow canister, disposable type.

Normal Oil Pressure – 35-85 psi @2000 RPM with engine hot.

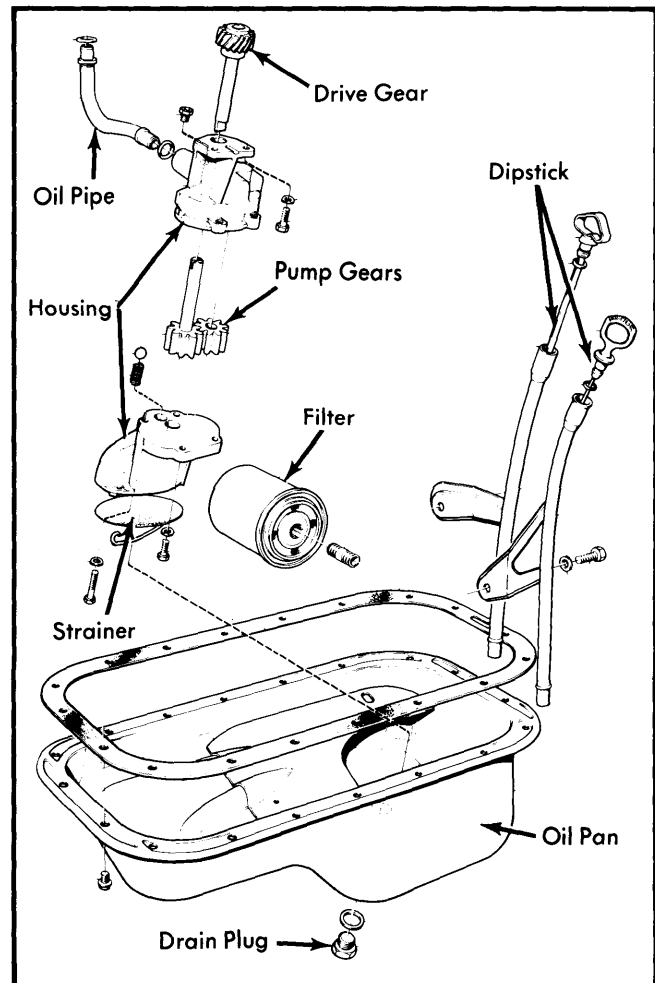

Fig. 8 Oiling System Components

ENGINE OILING SYSTEM

Engine utilizes a force-feed lubricating system. Oil circulates through oil pump to oil filter on outside of engine block

240 SERIES 4 CYLINDER (Cont.)

assembly. From filter, oil is forced to drilled gallery in center of block, where it moves under pressure to main bearings. Main bearings are drilled to permit lubricant to pass on to connecting rod and camshaft bearings.

Oil from camshaft bearings is used to lubricate discs, valves, and cylinder head assembly. Cylinder walls and rings are lubricated by the splash from connecting rods. Excess oil from all areas returns to sump through drain holes in block assembly.

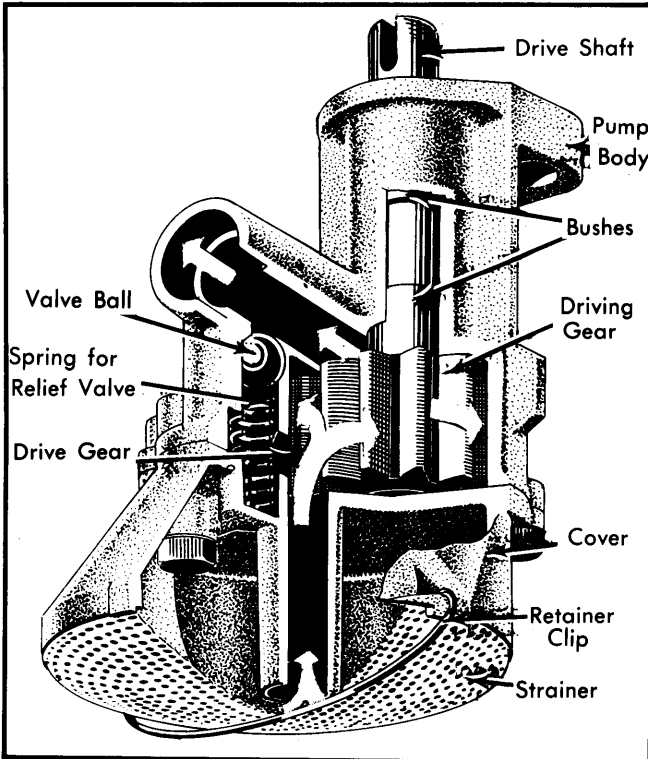

Fig. 9 Cutaway & Operational View of Oil Pump Assembly

OIL PUMP

1) Remove oil pan and related parts. See *Oil Pan Removal*. Pull oil pump out of engine, disassemble and clean all parts thoroughly. Check all parts for excessive wear or signs of fatigue.

2) Measure backlash (clearance) between pump gears. It should be .006-.014" (.15-.35 mm). Also measure end play of gears. Allowable end play is .0008-.0048" (.02-.12 mm). If any parts show excessive wear or play, replace necessary components. Drive shaft and gear are matched set and must be replaced as an assembly.

3) Reinstall oil pump, making sure that sealing rings on oil delivery pipe are securely in place. Be sure oil pump properly engages pump drive shaft. Replace oil pan and related components.

ENGINE COOLING

WATER PUMP

Removal & Installation - 1) Remove expansion tank cap, open engine block drain cock, and disconnect lower radiator hose at radiator. Remove fan shroud and fan. Loosen alternator and air pump and remove drive belts.

2) Remove water pump pulley, timing gear cover, and lower radiator hose. Remove retaining bolt and slide coolant pipe rearward. Remove pump.

3) Clean all surfaces. Place new sealing ring on coolant pipe. Install new gasket when mounting pump. Install other components previously removed. Fill with coolant.

Thermostat - Standard wax-type (marked 87°) opens at 189° F (87° C); fully open at 207° F (97° C).

Cooling System Capacity - All models, 10 quarts.

ENGINE SPECIFICATIONS

GENERAL SPECIFICATIONS										
Year	Displ.		Carburetor	HP at RPM	Torque (Ft. Lbs. at RPM)	Compr. Ratio	Bore		Stroke	
	cu. ins.	cc					in.	mm	in.	mm
1979 B21F	130.0	2130	F.I.	107@5250	117@2500 [Ⓢ]	9.3:1	3.623	92	3.150	80

[Ⓢ] - Calif. 114@2500.

VALVES

Engine & Valve	Head Diam. In. (mm)	Face Angle	Seat Angle	Seat Width In. (mm)	Stem Diameter In. (mm)	Stem Clearance In. (mm)	Valve Lift In. (mm)
B21F Intake	1.732 (44)	45.5°	44.75°	.068-.092 (1.7-2.3)	.3134-.3138 (7.96-7.97)	.0012-.0024 (.030-.060)	.44 (11.2)
Exhaust	1.278 (35)	45.5°	44.75°	.068-.092 (1.7-2.3)	.3122-.3126 (7.93-7.94)	.0024-.0035 (.060-.090)	.44 (11.2)

Volvo Engines

240 SERIES 4 CYLINDER (Cont.)

ENGINE SPECIFICATIONS (Cont.)

PISTONS, PINS, RINGS						
Engine	PISTONS	PINS		RINGS		
	Clearance In. (mm)	Piston Fit In. (mm)	Rod Fit In. (mm)	Rings	End Gap In. (mm)	Side Clearance In. (mm)
B21F	.0004-.0012 (.010-.030)	Push Fit	Push Fit	2 Comp.	.0138-.0217 (.35-.55)	.0016-.0028 (.040-.072)
				Oil	.010-.016 (.25-.40)	.0012-.0024 (.030-.062)

CRANKSHAFT MAIN & CONNECTING ROD BEARINGS							
Engine	MAIN BEARINGS				CONNECTING ROD BEARINGS		
	Journal Diam. In. (mm)	Clearance In. (mm)	Thrust Bearing	Crankshaft End Play In. (mm)	Journal Diam. In. (mm)	Clearance In. (mm)	Side Play In. (mm)
B21F	2.4981-2.4986 (63.451-63.464)	.0011-.0033 (.028-.083)0015-.0058 (.037-.147)	2.1255-2.1260 (53.987-54.000)	.0009-.0028 (.024-.070)	.006-.014 (.15-.35)

VALVE SPRINGS			
Engine	Free Length In. (mm)	PRESSURE Lbs. @ In. (kg @ mm)	
		Valve Closed	Valve Open
B21F	1.77 (45)	63-72@1.50 (29-33@38)	160-178@1.06 (73-81@27)

CAMSHAFT			
Engine	Journal Diam. In. (mm)	Clearance In. (mm)	Lobe Lift In. (mm)
B21F	1.1437-1.1445 (29.050-29.070)	.0012-.0028 (.030-.071)

TIGHTENING SPECIFICATIONS

Application	Ft. Lbs (mkg)
Cylinder Head Bolts	
Step One	44 (6.0)
Step Two	Ⓣ76-83 (10.5-11.5)
Main Bearing Caps	85-91 (11.8-12.6)
Connecting Rod Caps	43-48 (6.0-6.6)
Camshaft Bearing Caps	13-16 (1.8-2.2)
Exhaust & Intake Manifold Bolts	15 (2.0)
Flywheel Bolts	47-54 (6.5-7.5)
Engine Mount Bolts	15 (2.0)
Spark Plugs	25-29 (3.5-4.0)
Sprockets	
Camshaft	37 (5.1)
Intermediate Shaft	37 (5.1)
Crankshaft	122 (16.9)
Fan Bolt	33 (4.6)
Drive Belt Tensioner Nut	37 (5.1)
Oil Pan Bolts	8 (1.1)

Ⓣ Run engine for 10 minutes, until hot, allow engine to cool 30 minutes, and retorque.