

911 SC & TURBO 6 CYLINDER

ENGINE CODING

ENGINE IDENTIFICATION

Engine identification number is die stamped on blower fan support near oil temperature sensor. Second digit of number identifies engines as follows:

Application	Engine Code
911 SC	
Federal	2
California	5
Turbo	8

ENGINE & CYLINDER HEADS

ENGINE

1) Place vehicle on jack stands. Disconnect negative battery cable. Remove air cleaner. Loosen engine block vent hose at engine and plug vent cover hole. If equipped with air conditioning, detach compressor at console but leave hoses attached.

NOTE — Air conditioning system is under pressure, DO NOT disconnect hoses until pressure is released.

2) Remove relay plate cover and disconnect the engine wires at; relay plate, adapter plug, relay plate socket, and ignition control unit. Remove fuel hoses at filter and return line. Disconnect accelerator linkage.

3) Remove rear center tunnel cover in passenger compartment. Remove rubber boot in tunnel by pulling forward over the selector rod. Loosen shift rod coupling and pull coupling off of transmission inner shift rod.

4) Disconnect speedometer sensor wires in tunnel. Remove rubber plug with wire plug. Drain crankcase and plug hoses

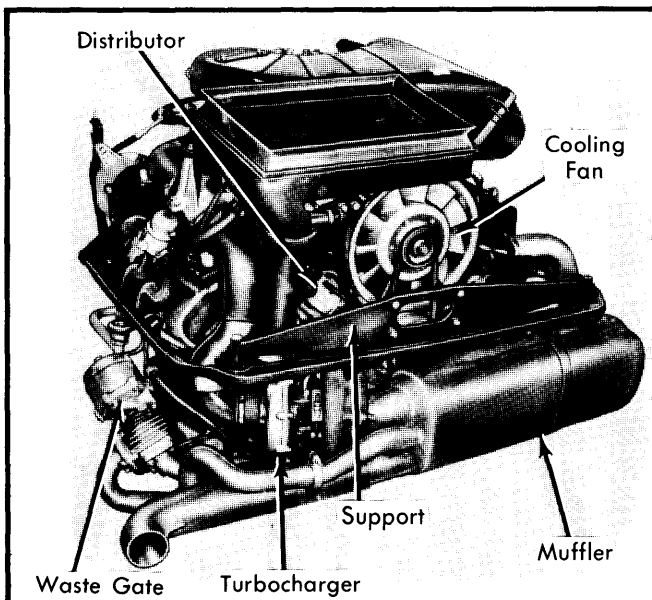

Fig. 1 View of Porsche 6 Cylinder Engine (Turbo Shown)

on engine and oil tank. Remove heater hoses at exchangers. Remove rear stabilizer.

5) Disconnect ground strap at body and battery wires at starter. Disconnect accelerator linkage from pedal and clutch cable from transmission. Loosen drive shaft flange socket head screws at transmission.

CAUTION — Be careful when jacking assembly upward not to damage the secondary air injection pipes.

6) Place a suitable jack under engine/transmission assembly and apply a little upward pressure to relieve tension on motor mounts. Remove transmission and engine mount bolts. Lower engine/transmission assembly out of vehicle.

CAUTION — Do not move vehicle unless drive shafts are suspended horizontally, to prevent damage to dust covers.

Installation — Reverse removal procedure and note the following: Do not clamp heater hoses, slide them onto the exchangers just before the engine/transmission assembly is in final installation position.

CYLINDER HEADS

Removal — 1) With fuel injection system removed, take off distributor cap and spark plug wires. Remove cooling air ducts, cover shrouds, ducts connecting air blower outlets and heat exchanger inlets with cover shrouds.

2) Remove rear engine mount (transverse leaf spring) from holder. Remove fuel pump and hoses, exhaust pipes with engine mounting bracket, blower pulley and drive belt. Loosen both screws of band strap which attaches alternator to blower housing and pull housing rearward. Disconnect alternator cables and remove blower housing with alternator.

3) Remove heat exchanger using suitable wrenches (P 205 & P 217). Disconnect camshaft oil lines between crankcase and chain housing covers. Remove covers. Remove chain tensioner, pivot lever and chain sprocket as an assembly.

4) Remove camshaft sprocket nuts using suitable tools (P 202 & P 203). Withdraw sprocket dowel pin with tool (P 212). Use a screwdriver to lift spring retainers from groove and remove chain guides. Remove camshaft sprockets and flanges. Pry Woodruff keys from camshafts.

NOTE — Each cylinder has a separate head. If camshaft housing is removed, any single head may be removed. If camshaft housing is left attached to cylinder heads, cylinder heads and camshaft housing may be removed as an assembly.

5) To remove a single head, rotate camshaft to take load off of rocker arm shaft to be removed. Loosen and remove rocker arm shafts and remove camshaft housing. With suitable tool (P 119), remove cylinder head nuts and lift off cylinder head.

NOTE — Mark cylinder heads, cylinders and camshaft housings for reassembly in original positions.

6) To remove all 3 cylinder heads and camshaft housing as an assembly, evenly loosen and unscrew cylinder head nuts with suitable tool (P 119).

911 SC & TURBO 6 CYLINDER (Cont.)

Installation — 1) Place cylinder head gaskets on cylinders with perforated side of steel insert facing cylinder. Install cylinder heads and oil return tubes at same time. Coat oil return tubes with engine oil for easier installation. Lightly tighten cylinder head nuts.

NOTE — Split (2 piece) oil return pipes may be installed without removing and disassembling the engine. If using this type, all "O" rings and seals must be lightly oiled and pipe telescoped. Extend pipe until end seals are seated and place retaining ring in its groove. Short pipe must be installed in crankshaft housing.

2) Install cool air shrouds and attach with clamps. Thinly coat camshaft housing gasket with gasket compound. Slide camshaft housing onto mounting studs. Tighten camshaft housing nuts down a few turns to ensure gasket seal. Install Allen screws in proper location and tighten camshaft housing in a crosswise pattern.

NOTE — Camshaft housings are interchangeable, but camshafts are not. Camshafts must be positioned on their proper side. See Fig. 5.

3) Tighten cylinder head nuts in a crosswise pattern, checking that camshaft does not bind in housing. If camshaft binds, loosen cylinder head nuts and tighten in a different sequence. With cylinder head nuts tight, camshaft must be free to rotate.

4) Install rocker arms and shafts so that grooves in shafts are recessed approximately .060" (1.52 mm) into bores. See Fig. 2. Tighten Allen bolts to 13 ft. lbs. (1.8 mkg) using suitable tools (P 210 & P 211).

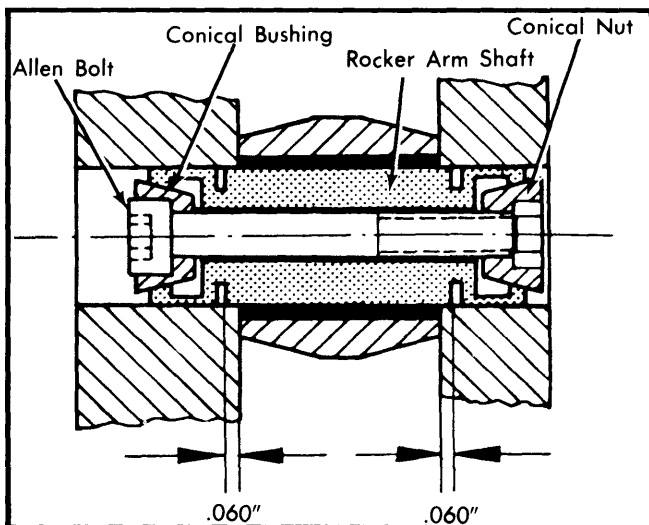

Fig. 2 Cross Sectional View of Rocker Arm Shaft Assembly

5) Install gasket, "O" ring, sealing flange, thrust plate, spacer, Woodruff key and camshaft sprocket flange as shown in Fig. 3. No provision is made to adjust camshaft end play, if sealing flange is worn, replace it.

6) Install camshaft sprockets and check chain alignment. See Fig. 11. Install heat exchanger, then chain tensioner. Slide chain guides on mounting studs. Lift retaining spring with screwdriver and slide chain guide into place. Install chain ten-

sion pivot lever and sprocket. Ensure that oil holes in pivot stud face upward.

7) Fill and bleed chain tensioners. Depress and install tensioners. Left tensioner may be positioned in only far enough to let camshaft nut be installed after valve timing. See *Valve Timing*. Install chain housing covers and camshaft oil lines. To complete installation, reverse removal procedures.

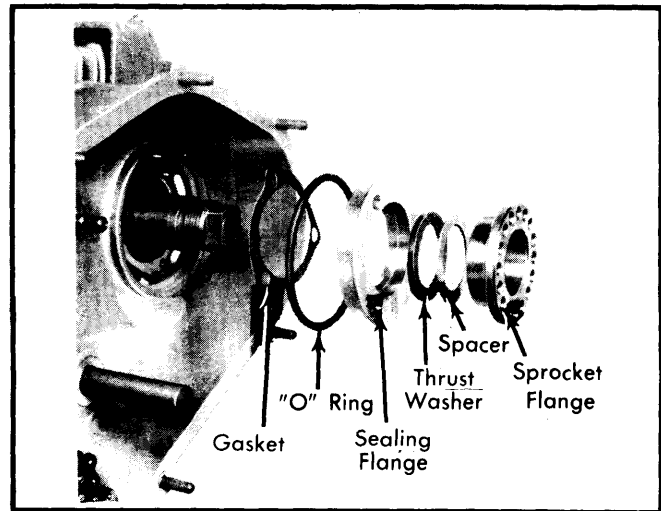

Fig. 3 Assembling Components to Install Camshaft Sprocket Flange and Sprocket

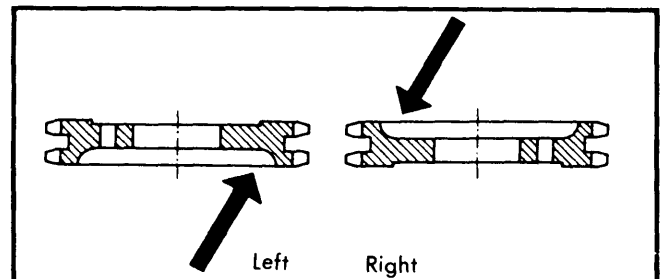

Fig. 4 Camshaft Sprocket Position (Viewed from Blower End of Engine)

CAMSHAFTS

CAMSHAFTS

Removal — 1) With engine out of vehicle, remove rocker covers and rocker arm assemblies. Remove muffler, oil hose from crankcase to chain housing cover, chain tensioner and chain tensioner sprocket.

2) On 911 models, remove belt pulley from left camshaft. Remove bearing and chain housing covers. Remove ball bearing from camshaft with a puller.

3) Unscrew nuts attaching camshaft sprocket with suitable tools (P 202 & P 203). Remove dowel pin from camshaft sprocket with tool (P 212). Pull sprocket and sprocket flange from camshaft. Remove 3 attaching screws and sealing flange with "O" ring, and withdraw camshaft rearward. See Fig. 3.

NOTE — Camshafts are not symmetrical and must be replaced on side they were removed from during disassembly. Camshaft housings for 911 and Turbo are identical, however Turbo camshafts use 4 bearings instead of 3.

911 SC & TURBO 6 CYLINDER (Cont.)

CAMSHAFT END THRUST

Measure camshaft end play with a dial indicator. If play is excessive, replace aluminum thrust washer located behind camshaft sprocket flange.

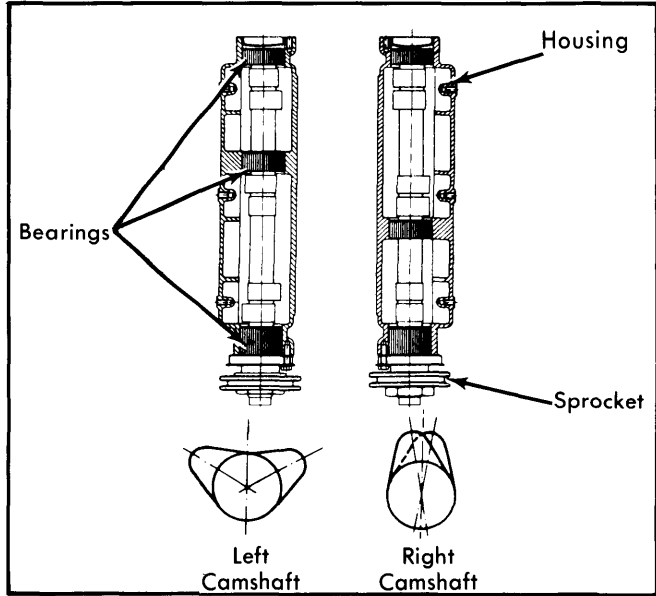

Fig. 5 Camshaft and Housing Viewed from Blower End of Engine (911 Shown)

TIMING CHAIN

Remove timing chain housing covers. Remove chain tensioner and chain tensioner sprocket. Remove timing chains. Install in reverse order of removal, ensuring that valve timing and chain alignment are as specified. See Figs. 6 and 7.

VALVE TIMING

1) Rotate crankshaft until mark "Z 1" on crankshaft pulley aligns with mark on crankcase. Use suitable tool (P 202) to rotate camshaft until dot on end of shaft is on top of camshaft vertical centerline. See Fig. 7. Find hole in camshaft sprocket which exactly lines up with camshaft flange and insert dowel pin. Install lock washer and nut.

CAUTION — Use care when rotating crankshaft or camshafts so that valve and piston do not collide. If resistance is felt, back off a little and rotate camshaft until you are free to continue.

2) Adjust cylinder No. 1 intake valve clearance to .040" (1 mm). Install a dial indicator with pressure foot resting squarely on valve spring collar. Preload indicator to .4" (10 mm) to provide for valve movement. Depress chain tensioner with screwdriver on side to be measured and block it with a piece of metal.

3) Rotate crankshaft 360° until "Z 1" (TDC) mark is aligned with mark on crankcase. Read dial indicator and compare with measurement given in *Intake Valve Lift Table*.

4) If correct valve opening measurement is not achieved, loosen camshaft nut, remove dowel pin and rotate camshaft until valve is open correct amount. Locate holes which align exactly and install dowel pin. Make sure crankshaft remains on TDC. Rotate crankshaft 2 complete revolutions and recheck valve lift. Repeat timing procedure if necessary. Repeat procedure on No. 4 cylinder for other side of engine.

Intake Valve Lift

Application	In. (mm)
911 SC & Turbo035-.423" (.9-1.1)

VALVES

VALVE ARRANGEMENT

All upper valves are intake.

All lower valves are exhaust.

VALVE GUIDE SERVICING

1) In order to avoid spreading the end of the valve guide when removing it, mill the guide down to the head on the camshaft side. A .433" (11 mm) drill bit may be used if milling tool not available. Drive valve guide out into combustion chamber.

2) Using a hole gauge, measure bore in cylinder head. Turn oversize guide down in a lathe so that O.D. gives an interference fit of .0024-.0035" (.060-.090 mm).

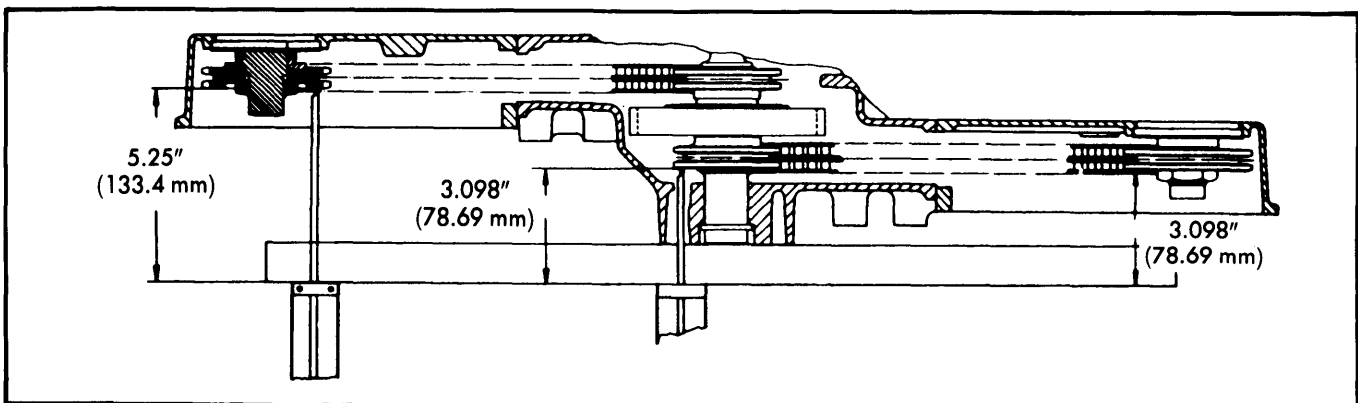

Fig. 6 Top View Showing Timing Chain Alignment

911 SC & TURBO 6 CYLINDER (Cont.)

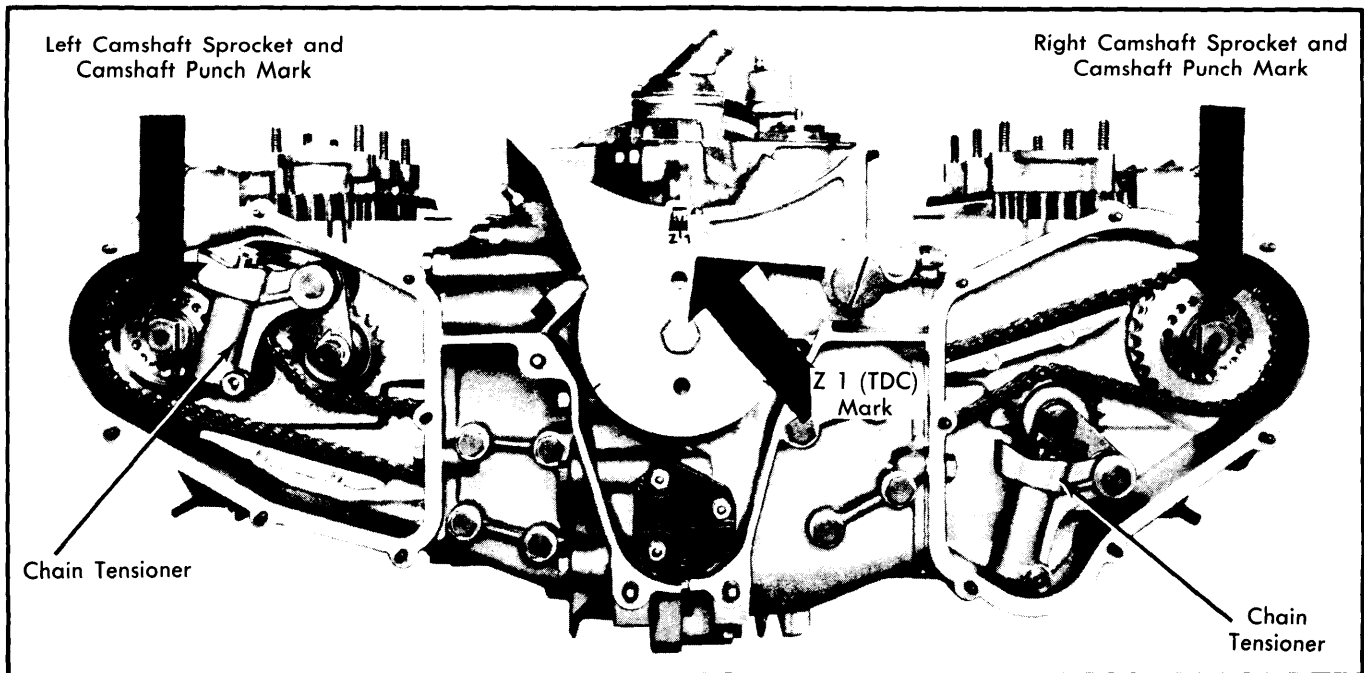

Fig. 7 View of Engine from Blower End (Rear of Car) Showing Valve Timing Marks

3) Press valve guide into head from camshaft side until a measurement of $.5196''$ (13.2 mm) is reached. (See Fig. 5). Use suitable grease as a lubricant when pressing in valve guides. Bore or ream valve guide I.D. to $.3543-.3549''$ (8.99-9.01 mm).

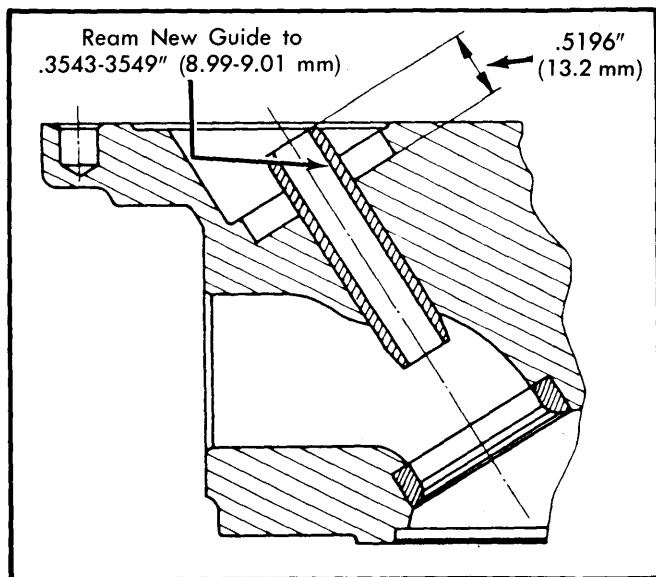

Fig. 8 Cross Sectional View of Valve Guide for Replacement

VALVE STEM OIL SEALS

Removal & Installation — Using a suitable spring compressor, remove valve keepers and take off valve springs with collar. Remove valve stem oil seal from end of valve guide. Install new seal over stem, using caution to avoid damage to seal as it passes over keeper grooves. Force seal over end of valve guide evenly and install remaining components in reverse order of removal.

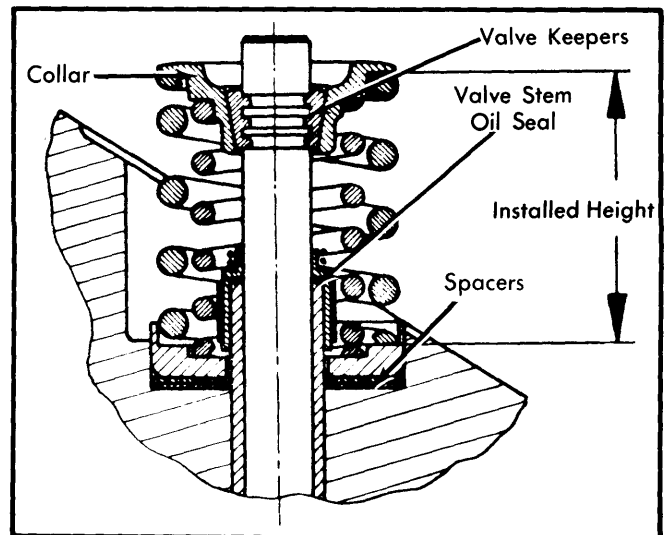

Fig. 9 Measurement of Valve Spring Installed Height

VALVE SPRING SERVICING

Remove valve springs as previously described and check for wear or fatigue. Replace as necessary and install with closely wound coils next to cylinder head. Check installed height with special tool (P 10) and add or remove spacers under the valve spring to attain specified installed height.

ROCKER ARMS

Using an Allen wrench, loosen rocker arm shaft bolt. Slide rocker shaft out of cylinder head and remove arm. Check rocker arm shaft and bushing for wear and replace as required. Install rocker arm shaft with Allen bolt facing either No. 2 or No. 5 cylinder. Center shaft in housing and tighten Allen bolt. See Fig. 2.

911 SC & TURBO 6 CYLINDER (Cont.)

Rocker Arm Specifications (In.)

Application	Diameter	Wear Limit
Rocker Arm Bushing7090-.70947106
Rocker Arm Shaft7080-.70847074
Rocker Arm Width	1.015-1.019	1.011
Housing Width	1.023-1.029	1.033

VALVE CLEARANCE ADJUSTMENT

1) Valve clearance should be set to .004" (.10 mm) with engine cold. If valves or seats have been reground, set clearances to .010" (.25 mm), run engine for one-half hour, then reset valves to original cold clearance.

2) Adjust valves in firing order sequence: 1,6,2,4,3 and 5. Rotate to TDC of firing stroke on No. 1 cylinder and adjust clearance. Rotate crankshaft 120° for each cylinder to be adjusted until complete.

NOTE — Cylinders are numbered from pulley end on left side, 1, 2, and 3, with 4, 5 and 6 on right side, 6 at flywheel end.

PISTONS, PINS & RINGS

OIL PAN

Remove nuts attaching oil pan (strainer cover plate) and remove strainer plate gaskets and strainer. Clean and inspect strainer and cover plate. Using new gaskets, replace strainer and cover plate. Ensure that oil strainer hole slides over pickup tube.

PISTON ASSEMBLY

Mark piston and cylinder for proper assembly location. Remove cylinders and take out piston pin circlip. Heat piston to approximately 176°F (80°C) and press out pin. Clean and inspect piston, rings and pin for each cylinder. Replace parts as necessary.

NOTE — See measurement procedures in *Fitting Pistons*.

FITTING PISTONS

The Turbo Carrera model uses a light alloy forged and lead coated piston. Piston crown is nearly flat and is marked with a symbol indicating flywheel direction. Pistons may only be installed one way due to .051" (1.5 mm) offset of pin from center.

The 911 SC piston has a depressed dome shape, and this depression must face the exhaust valve when installed. Pistons must be of same weight class and cylinders of same size in order to prevent unbalance of the engine.

1) Measure cylinder for wear and out-of-round. Cylinders and pistons are marked according to size. "0" indicates standard, while "1" or "2" indicates first or second oversize. Measure cylinder diameter 1.18" (30 mm) below top edge of cylinder.

2) Take one measurement in line with thrust face and another at 90° to this measurement. Cylinder is worn if diameter measurement is more than .004" (0.1 mm) beyond diameter specification. If difference in the two measurements is more than .0016" (.04 mm), then cylinder has exceeded its ovality limit.

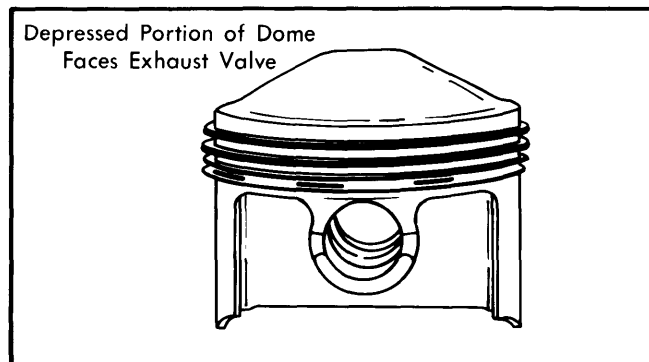

Fig. 10 911 SC Model Type Piston Head Shape

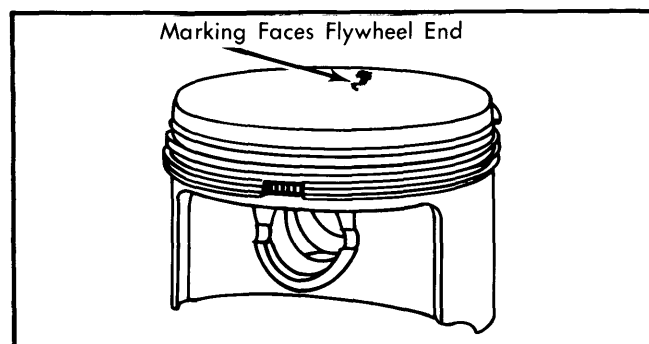

Fig. 11 Turbo Engine Piston Shape

3) Position piston rings in bottom of cylinder and measure ring gap. Check side clearance in piston ring grooves. Install rings on piston with marking "TOP" facing upward.

CRANKSHAFT MAIN & CONNECTING ROD BEARINGS

MAIN BEARING SERVICE

1) Separate crankcase halves. Lift out crankshaft and connecting rods. Place crankshaft on a suitable stand and remove connecting rods. Inspect crankshaft and connecting rods for wear, damage or out-of-true. Crankshaft main journals 1 through 7 and all connecting rod journals have the same diameter. Replace bearings or fit undersize bearings as required.

NOTE — Connecting rod bolts are stretch bolts and should never be reused. Replace connecting rod bolts whenever rods are disassembled.

2) Main bearing No. 8 is a special bearing with an external "O" ring and an internal oil seal. A steel dowel pressed in the crankcase is used to locate No. 8 bearing and prevent it from turning. Use care when installing bearing so that dowel engages hole and not groove in bearing.

911 SC & TURBO 6 CYLINDER (Cont.)

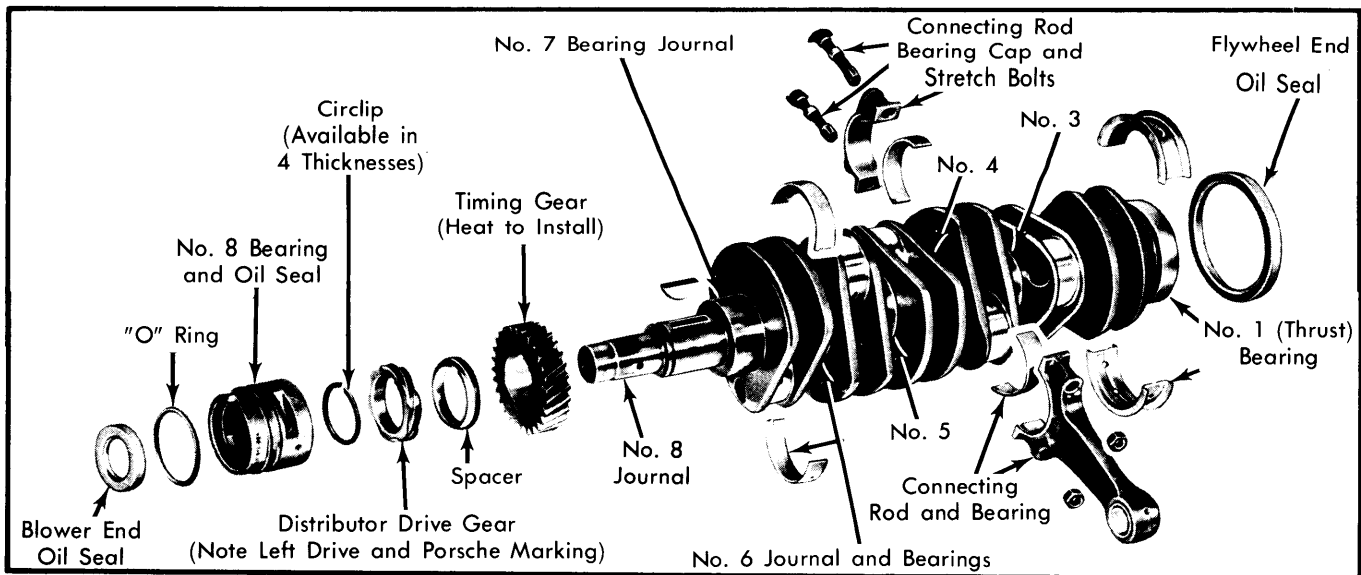

Fig. 12 Crankshaft Assembly with Component Locations

THRUST BEARING ALIGNMENT

Check end play at No. 1 main bearing. Width of No. 1 bearing is 1.1024-1.1044" (28.0-28.05 mm). Maximum wear limit is .011" (.28 mm) beyond specifications. Replace main bearing or crankshaft if excessive wear is present.

MAIN BEARING OIL SEALS (BLOWER END)

Remove belt pulley. Using a screwdriver, pry out old seal. Coat new seal with oil and press in place with suitable tool (P 216).

NOTE — Distributor drive gear now turns distributor counter-clockwise and is marked with a Porsche emblem. Old style gear (clockwise drive) is marked with VW emblem.

MAIN BEARING OIL SEAL SERVICE (FLYWHEEL END)

Remove flywheel. Displace oil seal with a chisel or drift and pry out with screwdriver. Coat outer seal edges with sealing compound and press into crankcase with driver (P 215) until seal is flush with face of crankcase.

INTERMEDIATE SHAFT BEARING SERVICE

With crankcase halves separated, lift out intermediate shaft and bearings. Inspect shaft and bearings for wear or damage and replace as necessary. Undersize bearings are NOT available.

ENGINE OILING

Oil Capacity — Total system capacity for both 911 SC and Turbo Carrera is 13.7 quarts. Oil change requires 10.6 quarts. Check oil level with dipstick while engine is idling at operating temperature.

Oil Filter — Disposable spin-on type.

Normal Oil Pressure — 911SC and Turbo should have 65 psi (4.6 kg/cm²) oil pressure at 5000 RPM with an oil temperature of 165°F (80°C).

Pressure Relief and Safety Valves — Identically constructed coil spring operated valves. Safety valve is set to operate at a higher pressure than relief valve.

ENGINE OILING SYSTEM

Lubrication is dry sump type. Two independent oil pumps provide for pressure and suction in system. Pressure pump takes oil from an externally mounted oil tank and forces oil to individual oil passages for all main bearings. From main bearings, a drilled passage in crankshaft carries oil to connecting rod bearings. Another passage leads to front bearing of intermediate shaft. A passage in intermediate shaft takes oil to rear bearing of shaft.

Camshaft oiling is accomplished by external oil lines leading to camshaft housings. Camshaft housings contain aluminum tubes with holes; three holes of .12" (3.0 mm) diameter carry oil to lubricate camshaft. Six holes of .04" (1.0 mm) diameter splash oil on camshaft lobes. Remaining three holes allow oil to splash against intake valve cover in such a manner that it will drip on rocker arms and valve stems.

Suction pump takes oil from engine sump through a strainer and forces it through oil filter to oil tank. Oil collected in lower part of camshaft housing is returned to crankcase by oil return pipes. Suction pump then returns oil to oil tank. A tube in oil tank carries oil to base of oil tank and filter. The turbo charger is lubricated from a branch off of oil pressure indicator or oil temperature indicator.

Oil pressure regulation is controlled by means of four separate valves. A thermostatically controlled valve directs oil directly to engine when temperature is below 176°F. When temperature is above 176°F, oil flows through oil cooler and then to main bearings. A pressure relief and safety valve located in right crankcase half opens if oil pressure rises above 76.9-99.6 psi and oil is passed directly into crankcase. A safety valve is mounted in left crankcase half immediately after oil pump. It operates in event of a defective pressure relief valve to prevent damage to oil cooler or oil lines. As a safety measure, by-pass valves are built into filter base and filter body. If oil pressure

Porsche Engines

911 SC & TURBO 6 CYLINDER (Cont.)

exceeds 28.4 psi, oil by-passes oil filter and flows directly into oil tank.

OIL PUMP

Oil pump may be removed when crankcase halves are separated. No repair of pump is possible, replace if defective.

ENGINE COOLING

Cooling is accomplished by means of a blower, consisting of an impeller and blower housing. Center of blower housing

holds support for alternator. Impeller and belt pulley are attached to alternator shaft. Blower delivers air required for cooling engine, oil cooler, alternator as well as fresh air for heating system. Cooling air flows through upper molded plastic air guides to cylinders and heads. Baffle plates provide uniform distribution of air. A duct incorporated into upper air guide leads air flow directly to oil cooler. Ducting for air delivery to heat exchangers is on both sides of blower housing. Adjustment of blower drive belt is done by adding or removing spacers between impeller housing and pulley half. This will cause belt to ride higher or lower on pulley, thereby loosening or tightening drive belt.

ENGINE SPECIFICATIONS

GENERAL SPECIFICATIONS										
Year	Displ.		Carburetor	HP at RPM	Torque (Ft. Lbs. at RPM)	Compr. Ratio	Bore		Stroke	
	cu. ins.	cc					in.	mm	in.	mm
1979 911 SC	182.7	2944	Fuel Inj.	172@5500	180@4200	8.5:1	3.74	95	2.77	70.4
Turbo	201.3	3299	Fuel Inj.	261@5500	291@4000	7.0:1	3.82	97	2.93	74.4

VALVES							
Engine & Valve	Head Diam. In. (mm)	Face Angle	Seat Angle	Seat Width In. (mm)	Stem Diameter In. (mm)	Stem Clearance In. (mm)	Valve Lift In. (mm)
2944 cc Intake	45°	45°
Exhaust	45°	45°
3299 cc Intake	45°	45°
Exhaust	45°	45°

CRANKSHAFT MAIN & CONNECTING ROD BEARINGS							
Engine	MAIN BEARINGS				CONNECTING ROD BEARINGS		
	Journal Diam. In. (mm)	Clearance In. (mm)	Thrust Bearing	Crankshaft End Play In. (mm)	Journal Diam. In. (mm)	Clearance In. (mm)	Side Play In. (mm)
2994 cc Jrnls 1-7	2.362 (60)	.0003-.0028 (.008-.07)	No. 1	.0043-.0076 (.11-.19)	2.085 (53)	.0011-.0034 (.028-.086)
Jrnl 8	1.220 (31)	.004 (.10)					
3299 cc Jrnls 1-7	2.362 (60)	.0003-.0028 (.008-.07)	No. 1	.0043-.0076 (.11-.19)	2.165 (55)	.0011-.0034 (.028-.086)
Jrnl 8	1.220 (31)	.004 (.10)					

Porsche Engines

911 SC & TURBO 6 CYLINDER (Cont.)

ENGINE SPECIFICATIONS (Cont.)

PISTONS, PINS, RINGS						
Engine	PISTONS	PINS		RINGS		
	Clearance In. (mm)	Piston Fit In. (mm)	Rod Fit In. (mm)	Rings	End Gap In. (mm)	Side Clearance In. (mm)
2944 cc & 3299 cc	.001-.002 (.025-.052)	Press Fit	.0007-.0015 (.018-.038)	No. 1	.004-.008 (.10-.20)	.003-.004 (.07-.10)
				No. 2	.004-.008 (.10-.20)	.001-.003 (.04-.07)
				Oil	.006-.012 (.15-.30)	.0008-.002 (.02-.05)

① — Limit .006" (.15 mm).

VALVE SPRINGS			
Engine	Free Length In. (mm)	PRESSURE ① Lbs. @ In. (kg @ mm)	
		Valve Closed	Valve Open
2994 cc	Intake	1.358 (34.5)
	Exhaust	1.358 (34.5)
3299 cc	Intake	1.319 (33.5)
	Exhaust	1.319 (33.5)

① — Measurement given is spring height; no pressure specification is provided. See *Valve Spring Servicing*.

VALVE TIMING				
Engine	INTAKE		EXHAUST	
	Open (BTDC)	Close (ABDC)	Open (BBDC)	Close (ATDC)
2994 cc	1°	53°	43°	3°
3299 cc	3°	37°	29°	3°

TIGHTENING SPECIFICATIONS	
Application	Ft. Lbs. (mkg)
Crankcase Joining Bolts	25 (3.5)
Camshaft Housing	18 (2.5)
Main Bearing Caps	25 (3.5)
Flywheel (9 Bolt)	65 (90)
Connecting Rod Caps	36 (5.0)
Cylinder Head	22 (3.3)
Crankshaft Pulley	58 (8.0)
Camshaft Nut	101 (14)
Rocker Arm Shafts	13 (1.8)