

## 604 V6

## ENGINE CODING

## ENGINE IDENTIFICATION

Engine serial number is stamped on 2 plates fastened to the left side of engine block in front of oil filter. The first plate is stamped with the engine type (151.9). Second is stamped with engine serial number. Last two letters of serial number are decoded as follows:

Application	Transmission	Engine Code
151.9 Engine .....	Manual .....	ZM
151.9 Engine .....	Automatic .....	ZA

## ENGINE &amp; CYLINDER HEADS

## ENGINE

**Removal** – 1) Remove hood, carburetor air cleaner and ducting. Drain automatic transmission (if equipped) and cooling system. Disconnect and remove battery.

2) Disconnect electrical leads to air conditioning system and electric fan. Disconnect radiator hoses, heater hoses, and on automatic transmission vehicles only, coolant hoses. On all

vehicles, remove fan shroud and radiator. Remove air conditioning condenser and compressor mounting bolts and swing these units clear to the right side.

**NOTE** – Do NOT disconnect any air conditioning system hoses or pressure connections.

3) Disconnect rear heater hose, fuel lines, vacuum lines, throttle linkage and electrical connections. Remove upper bolts from clutch housing or torque converter. On automatic transmission models, remove filler pipe. Remove front exhaust pipe connections and engine mounting bolts.

**NOTE** – After removing automatic transmission filler pipe, retighten upper lifting bracket bolt.

4) Remove muffler and exhaust pipe brackets and heat deflector. Remove starter mounting bolts and clutch housing or converter cover plates. Remove power steering mounting bolts but do NOT disconnect lines. With suitable sling (8.0135) and hoist, lift engine until transmission touches tunnel, then lower about  $\frac{3}{8}$ " (10 mm). Remove steering pump and hang to one side.

5) Fit propeller shaft tube support between muffler and body and tighten to support tube slightly. Remove steering coupling clamp bolt and replace rear steering rack bolts with slightly longer bolts. Remove front crossmember securing bolts and loosen rear bolts about 1" (30 mm) to lower crossmember.

6) On automatic transmission models, disconnect starter ring gear flange plate from torque converter. On all models, remove two lower housing securing bolts. Remove engine towards front. Use caution to avoid damaging power steering and automatic transmission cooling tubes. On automatic transmission models, hold torque converter in position.

**Installation** – To install, reverse removal procedure and note: Ensure clearance between steering wheel and column casing is  $\frac{5}{64}$ " (2 mm) and throttle controls are adjusted.

## CYLINDER HEADS

**NOTE** – Cylinder head removal maybe performed with engine in vehicle.

**Removal** – 1) Drain cooling system and remove engine hood. Remove air cleaner and ducts. Remove battery. Remove intake manifold and plug intake ports in cylinder heads. Remove insulating plate and hose connecting water pump to cylinder heads. Remove hose connecting heads.

2) To remove left head, lower the cross member and remove fuel pump. Loosen positive battery lead and remove ground cable. To remove right head, remove distributor, coil and filler well for automatic transmission (if equipped). For either head, loosen front muffler mounting and remove exhaust pipe clamp under manifold. For left head, remove bolt from flexible steering coupler, then lower crossmember by  $\frac{1}{8}$ " (3 mm).

3) Remove rocker arm cover and camshaft rear cover plate. Remove camshaft sprocket bolt access plug and position sprocket with drive stud or timing mark at top. Lock crankshaft in this position and loosen camshaft sprocket bolt. Place

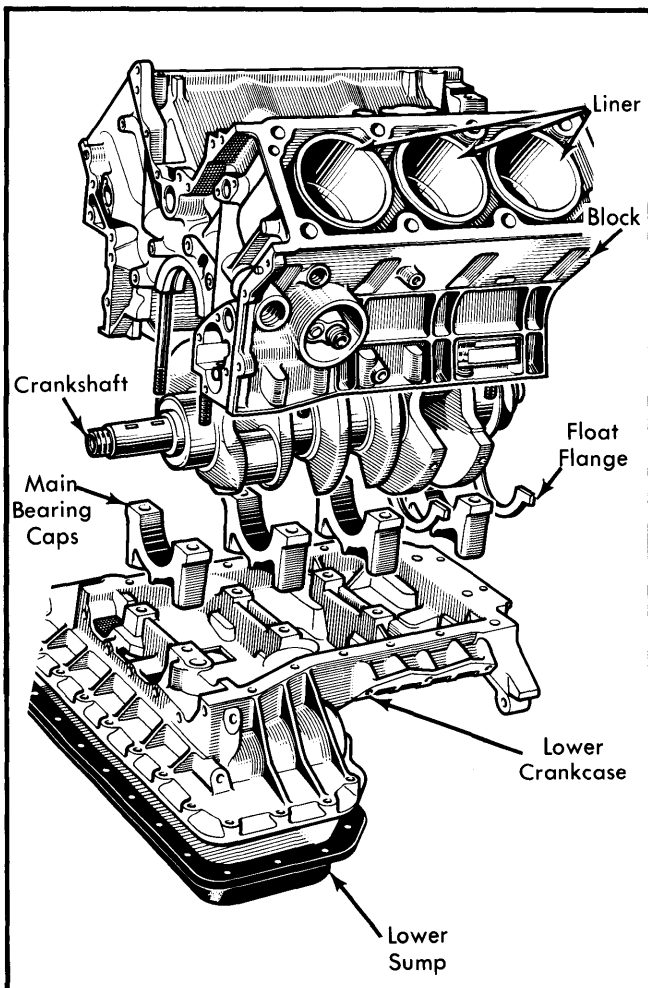
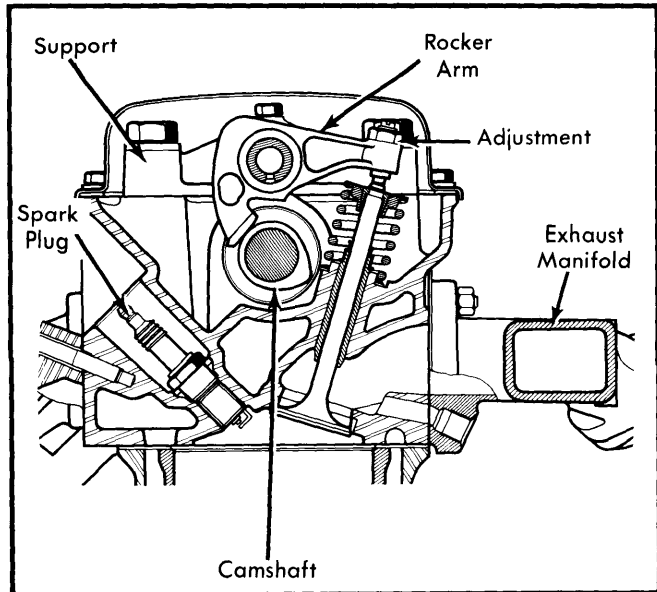


Fig. 1 Exploded View of Peugeot V6 Engine

## 604 V6 (Cont.)

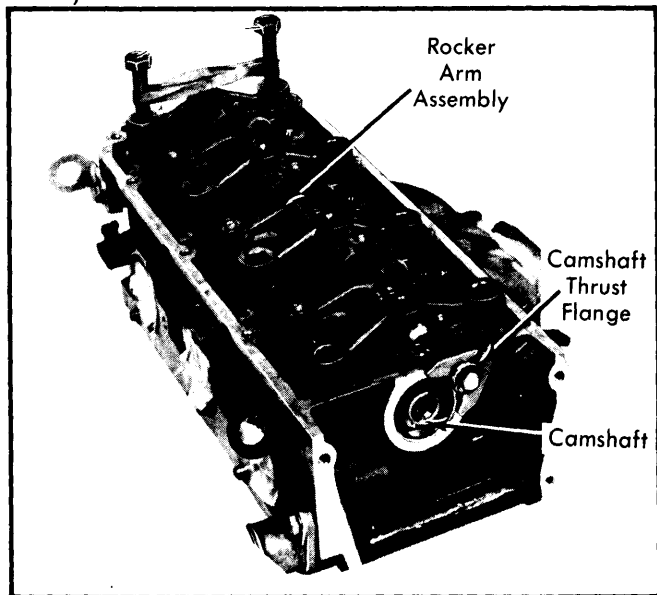
camshaft sprocket support (8.0134 M) on front of timing gear casing and tighten mounting bolts finger tight. Attach sprocket to support through one of the holes in the sprocket web by means of bolt and nut tightened to no more than 11 ft. lbs. (1.5 mkg).



**Fig. 2 Sectional View of Cylinder Head**

4) Remove all 8 cylinder head bolts. On left head, brake booster prevents full removal of 2 rearmost bolts. Lift these as far as possible and fasten together with a rubber band. Loosen camshaft thrust flange retaining bolt and slide it along elongated hole until free. On each head, remove 4 bolts securing timing gear casing. Remove heads by inserting 2 "L" shaped rods into cylinder head bolt holes and jiggling until free. Lift off cylinder head/rocker arm assembly.

**NOTE** — Timing chain tension must not be released. If accidentally released, timing cover must be removed in order to reposition chain tensioner. Retaining bars should be installed to prevent cylinder liner movement.



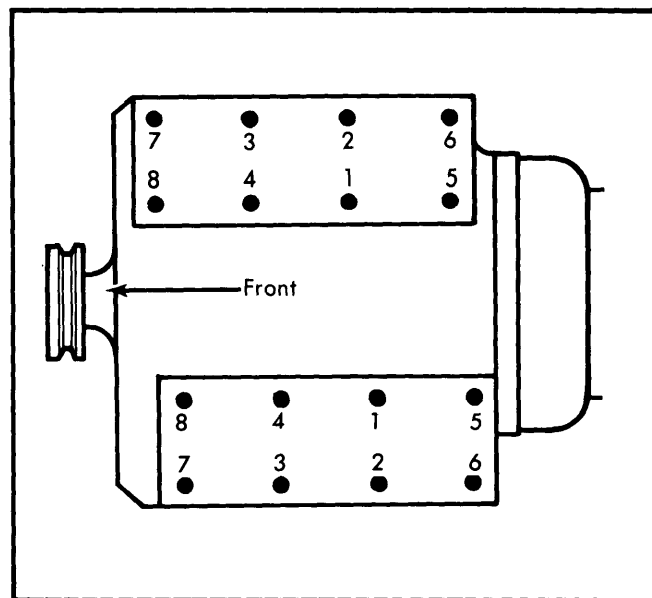
**Fig. 3 Left Cylinder Head with Rear Bolts**

**Installation** — 1) Insert a pin punch in each of the holes under the locating dowels and insert new dowels. Remove liner retaining bars and fit a new head gasket (dry) on block. Place cylinder head/rocker arm assembly into position carefully and hand tighten 4 timing gear case bolts. The 2 rearmost bolts must be installed prior to positioning assembly on block.

2) Carefully align keyways and insert camshaft into sprocket. Raise rocker arms and turn sprocket bolt until camshaft has entered sprocket fully, then tighten lightly. Install but do not tighten oiled cylinder head bolts in position. Remove camshaft sprocket support. Install camshaft thrust flange into camshaft flange and tighten bolts.

3) Hold crankshaft and tighten camshaft sprocket bolt. Initially tighten cylinder head bolts in order shown to 43 ft. lbs. (6 mkg), then loosen individually and retighten 14 ft. lbs. (2 mkg). Tighten each bolt in sequence an additional 90° (¼ turn) to final position. Tighten timing gear case bolts.

**NOTE** — Due to the position of the brake servo, the two rear bolts on the left head (inserted in head prior to installation) will require special attention. If in doubt about proper tension on any bolt, it must be fully loosened and the tightening procedures repeated.



**Fig. 4 Cylinder Head Tightening Sequence**

4) Tighten access plug, gear case and rear bearing cover plate bolts. Rotate crankshaft to bring No. 5 (center, right bank) piston to Top Dead Center and align notch in crankshaft pulley under "10" mark on timing plate. With vacuum advance diaphragm to rear and unmarked rotor arm to front of engine, install distributor. Align rotor arm marks and distributor body at 4 o'clock position. Snug securing clamp. See Fig. 5.

## 604 V6 (Cont.)

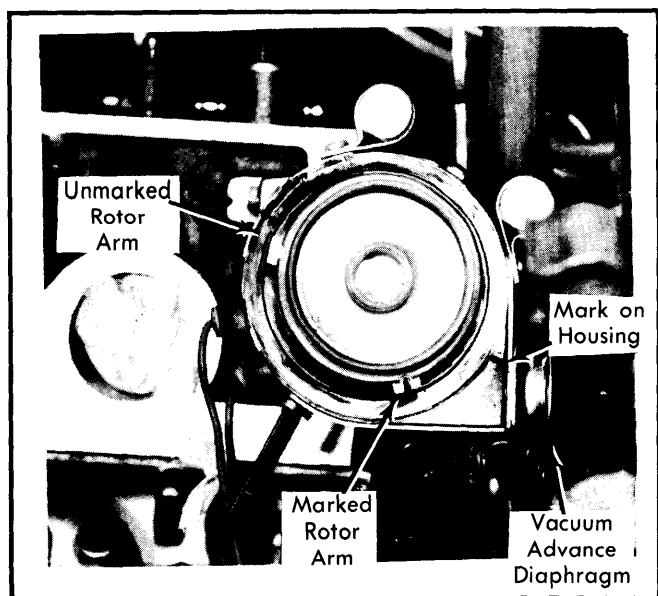


Fig. 5 Installing Distributor

## CAMSHAFT

## TIMING GEAR COVER

**NOTE** — Timing gear and cover repair work may be accomplished with engine installed or removed from vehicle.

**Removal** — 1) Rotate crankshaft so that notch in pulley is absolutely in line with the 10° mark on timing plate and lock flywheel in place with clamping tool. Drain engine oil and cooling system. Disconnect battery and all hose connections to radiator.

2) Remove and set aside the following: Air filter and ducting, radiator and struts, fan and casing, drive belts, power steering pump and support, crankshaft pulley, rocker arm covers, timing gear cover bolts and timing cover. Oil pump, chain tensioners and timing gears are now accessible.

**Installation** — To install, reverse removal procedure and note the following: Gasket faces and gaskets must be clean and dry. Timing plate 10° mark must be directly in line with pulley notch. Adhere to all torque specifications.

## CHAINS &amp; SPROCKETS

**Removal** — With timing case cover off, plug ports to crankcase unless crankcase is to be removed. Remove oil pump sprockets, drive chain, spacer, key and oil pump. Release chain tensioners. Mark position of camshaft drive chains if they are to be reused. Remove right camshaft sprocket and chain first, then left side. Remove chain tensioners and drive sprocket.

**Installation** — 1) Reinstall filters in front of block. Lock chain tensioner plungers in retracted position, then install tensioners. Install tensioner strips and fixed pads.

2) With keyway at top of crankshaft, insert key and install sprocket with position mark visible from outside. Turn crankshaft so that keyway is aligned to left cylinder bank and camshaft centerline. Place chain over left camshaft sprocket

with mark on sprocket between marks on chain. Fit chain over drive sprocket with mark on link in line with position mark on sprocket.

3) Rotate crankshaft clockwise to bring mark on drive sprocket in line with bottom oil pump mounting hole. Align marks on chain and sprockets as in Step 2) and tighten camshaft bolts. Unlock tensioners and allow to extend without assisting their movement. Tighten in position.

4) Fit spacer, key and oil pump drive sprocket on crankshaft. Install oil pump, sprocket and chain. Install cover as in TIMING GEAR COVER section.

## CAMSHAFT AND ROCKER ARM ASSEMBLIES

**Camshaft** — Remove thrust flange from front of head and rear bearing cover plate. Camshaft is removed and installed from rear of head. Left camshaft has fuel pump drive cam and right camshaft has distributor drive pinion.

**Rocker Arms** — Mark rocker arms for left or right head. Disassemble, keeping parts in same order as removed. Replace parts as necessary and reassemble in reverse order of disassembly.

## TIMING PLATE ADJUSTMENT

With intake manifold removed, rotate engine so that number 1 piston is approaching TDC on the firing stroke. Remove hex head plug near front of left bank of engine. Insert gauge rod to rest against crankshaft counterbalance weight. Turn crankshaft SLOWLY until rod enters slot and locks crankshaft. Check that notch in pulley is aligned with "0" on timing plate. If not, readjust plate and tighten in position.

## VALVES

## VALVE ARRANGEMENT

**Intake Valves** — Inboard side of heads.

**Exhaust Valves** — Outboard side of heads.

Valves are removed and refitted in the usual way using conventional tools.

**NOTE** — Cylinders are numbered from left bank flywheel end 1, 2 and 3; right bank 4, 5 and 6.

**NOTE** — Left and right rocker arm assemblies are identical, however, circlip end is at front of left head and to rear on right head. Flat end of boss on support must face toward circlip.

## VALVE CLEARANCE ADJUSTMENT

1) Engine must be cold. Rotate crankshaft so that number 1 cylinder is at TDC on firing stroke (rotor mark lined up with mark on distributor; notch on pulley under "0" on timing plate). Adjust number 1, 2 and 4 intake; number 1, 3 and 6 exhaust clearance.

2) Rotate crankshaft one full revolution so that mark on rotor arm is 180° from mark on distributor housing and notch in pulley is again under "0" mark on timing plate. Adjust number 3, 5 and 6 intake; number 2, 4 and 5 exhaust clearance.

## 604 V6 (Cont.)

### Valve Clearance Adjustment

Valve	In. (mm)
Intake .....	.004 (.10)
Exhaust .....	.010 (.25)

### PISTONS, PINS & RINGS

#### PISTON & ROD ASSEMBLY

**NOTE** — To accomplish further engine repairs, engine must be removed from car and placed on suitable stand.

1) Remove cylinder heads, sump and lower crank case. Mark positions of components to ensure proper placement for reassembly. Remove connecting rod cap nuts and bearing caps. Slide protective tubing over rod bolts and remove piston and liner assembly individually.

**NOTE** — Piston/rod assemblies must be kept with their respective liners. If piston is removed from rod, it will be necessary to install both a new liner and a new piston.

2) Match piston and liner. Mount piston and rod assembly with bearing end in soft jawed vise. Arrow on piston top should point away from installer so that when liner is installed, arrow will be in 12 o'clock and notches on liner will be in 3 o'clock positions. Lubricate piston/ring assembly and apply suitable ring compressor. Push liner down over piston assembly without turning until ring compressor is free.

3) Slide protective tubing over connecting rod bolts, then insert piston/liner assemblies in block starting with number one. Finger tighten connecting rod nuts until all assemblies are installed, then tighten to specifications. See *Fitting Cylinder Liners*.

#### FITTING CYLINDER LINERS

1) Prior to fitting or installing liners, block and liners must be absolutely clean to assure proper fit. Liners will have one, two or three machined marks on top of outboard edge corresponding to "A", "B" or "C" marked on top of piston. For final assembly, liners must project above cylinder block gasket face by .006-.009" (.16-.23 mm).

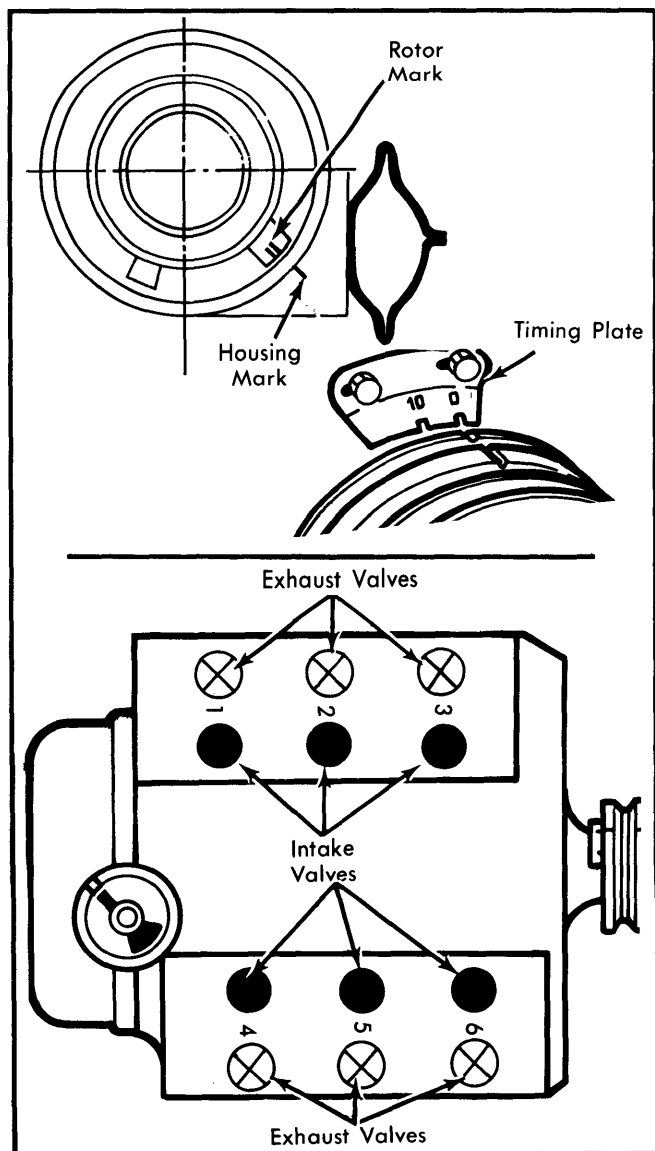
**NOTE** — Liner/piston assemblies must all be of the same category (I-A, II-B or III-C) when installed in any given engine. Do not attempt to install liners with different markings in the same engine.

2) Place liner in position without its seal and place measuring plate (8.0132) over liner with smooth side up. Place dial indicator in support on plate and take a reading at four points around top of liner. Difference should not exceed .0008" (.02 mm).

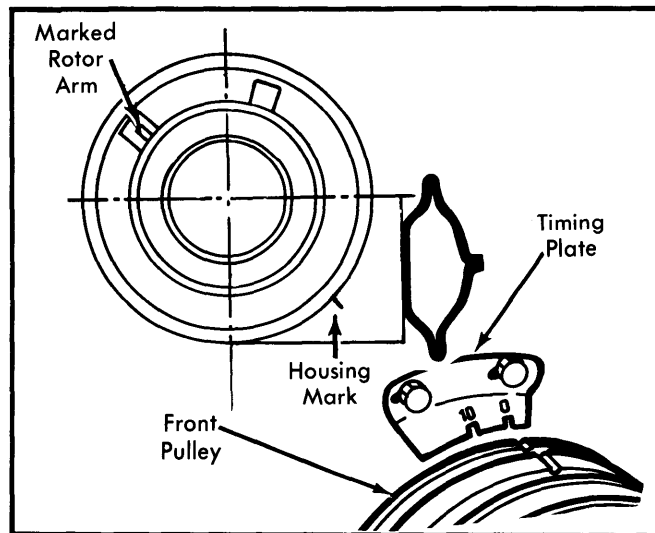
3) Measure liner projection through the three elongated holes in plate by placing plunger against block. Difference should not exceed .002" (.05 mm). To determine lower liner seal thickness, subtract largest of readings from .0091" (.23 mm).

#### Example:

First reading .....	.0039" (.10 mm)
Second reading .....	.0032" (.08 mm)
Third reading .....	.0035" (.09 mm)

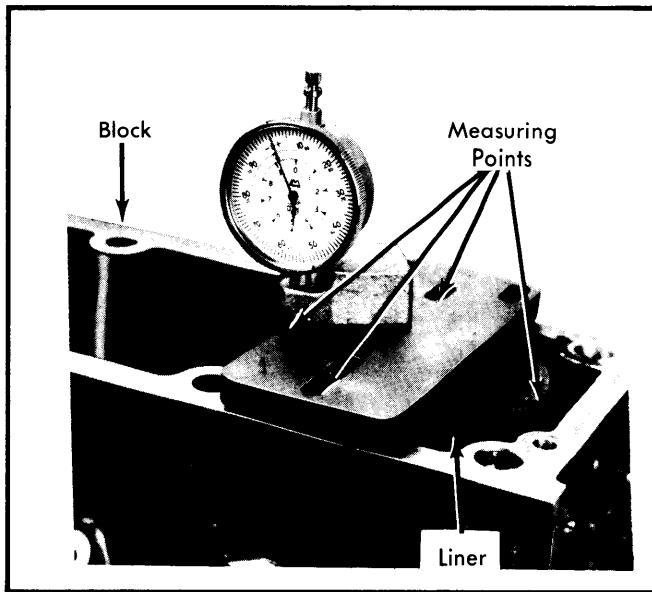


**Fig. 6 First Adjusting Position for Setting Valves**



**Fig. 7 Second Adjusting Position for Setting Valves**

## 604 V6 (Cont.)

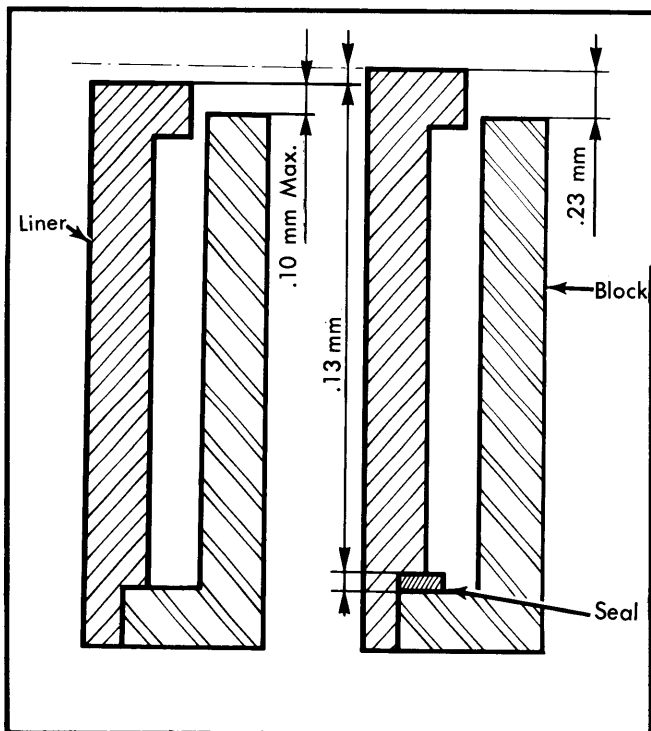


**Fig. 8 Measuring Liner Projection**

Subtract largest reading .0039" (.10 mm) from .0091" (.23 mm). Result .0052" (.13 mm) indicates thickness of lower liner seal.

### Liner Seal Thickness

Tab Color	Thickness - In. (mm)
Blue .....	.0034 (.087)
White .....	.0040 (.102)
Red .....	.0048 (.122)
Yellow .....	.0057 (.147)



**Fig. 9 Cylinder Liner and Seal Specifications**

4) Fit identical seals to liners with color tab marking toward top. Place liners in block so that tabs are visible and not trapped under adjacent liner. Repeat measurement as outlined in steps 2) and 3) with seal installed while holding plate down to flatten out seal. Check that height differences do not exceed .0016" (.04 mm).

**NOTE** - It is possible to adjust height differences on new liners by rotating them.

5) In case liner or liners project too far, select thinner seal and repeat measurement. Mark the order and positions of liners on top of liner and edge of block. Match piston and rod assemblies with liners and proceed as in *Piston & Rod Assembly*.

### PISTON PIN REPLACEMENT

1) Remove old wrist pin with drift (8.0134) and press. Discard old piston and inspect rod for overheating or galling. In order to satisfactorily assemble piston, pin and rod, wrist pin end of rod must be heated on hot plate.

**NOTE** - In order to properly install wrist pins, special tool sets 8.0134 and 8.0139 are required. The success of the operation depends on the speed with which it is carried out.

2) Arrange left (1, 2 & 3) rods with pistons and matched wrist pins for assembly. Install pistons with arrow head and DT mark upward in special tool and fit connecting rod thrust washer (F4) with number 1-2-3 up on tool. Place wrist pin on drift and tighten cone end finger tight. Immerse cone and pin in oil, then place rod inside piston to locate pin and washer.

3) With pin, drift and cone inserted in piston and rod, adjust support with thrust washer under center of large end of rod and tighten support. Remove drift and rod, then heat pin end of rods until resin core solder will melt on them. Collar end of rods must point downward on washer, then insert pin by hand until cone contacts base. Wait ten seconds and repeat for other rods.

4) Turn support washer over so that figure 4-5-6 is up, then arrange RIGHT side rods with collar pointing UPWARD. Repeat procedures used in Steps 2) & 3). Mark all assemblies for installation with felt tip pen.

**NOTE** - Pistons and pins are marked for wrist pin size. See following table:

Mark on Piston	Wrist Pin Color
① .....	Blue
② .....	White
③ .....	Red

### CRANKSHAFT MAIN & CONNECTING ROD BEARINGS

#### MAIN BEARINGS

1) Remove crankshaft and measure main bearing shells. Measure journals for size and maximum run out of .0012" (.03 mm). Clean out all oil passages, keyways and screw threads on crankshaft. Oil bearing shells and place in block with oil holes lined up with passages in block. Shells with groove go in block while those without are placed in bearing caps.

## 604 V6 (Cont.)

2) Place copper-plated faces of lower end float flanges against shoulders on crankshaft rear bearing area. Fit both front and rear bearing caps so that raised boss is on timing gear side.

3) Place spacers (part of tool set 8.0134) on front and rear bearing caps and tighten nuts to 22 ft. lbs. (3 mkg). Loosen nuts and check crankshaft end play with dial indicator. Play should be .003-.011" (.07-.27 mm). If not within specifications, replace float flanges. Float flanges are available in the following sizes: .0905", .0945", .0965" and .0985" (2.3, 2.4, 2.45 and 2.5 mm).

4) Use same procedures to fit connecting rod bearings as for main bearings. See PISTON & ROD ASSEMBLY.

### FITTING LOWER CRANKCASE

Remove main bearing spacers from caps. Assure that boss on main bearing caps is on timing gear (front) side. Locating sleeve and new "O" ring must be in position on oil pump. Coat joint face of block with sealing compound and install lower crankcase, all fastenings finger tight. Tighten all main bearing caps to 22 ft. lbs. (3 mkg) in order illustrated. Further angle tighten caps 1/4 turn (90°) in order shown. Tighten lower crankcase peripheral bolts to 13 ft. lbs. (1.75 mkg). Install anti-emulsion plate, strainer and sump with new cork gasket.

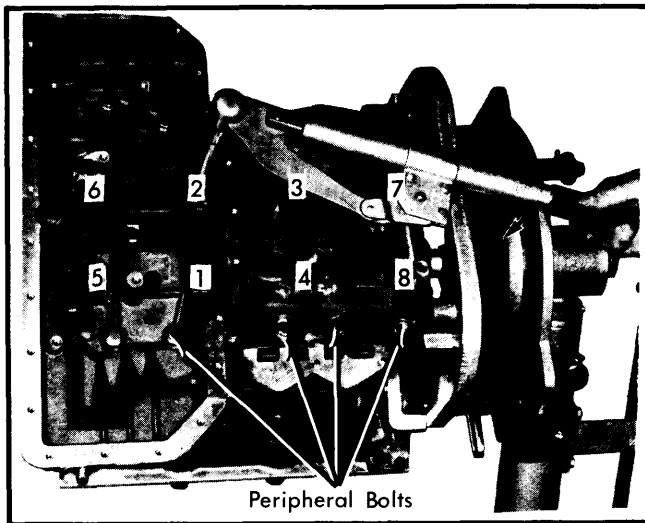


Fig. 10 Main Bearing Tightening Sequence

## ENGINE OILING

### ENGINE OILING SYSTEM

Positive displacement gear type pump is located at lower left side of engine under timing case cover. Pump is chain-driven from crankshaft. Oil is picked up through a screen and tube in lower sump, filtered through a 10 to 15 micron type filter and pressure fed through the oil gallery and passages to main and connecting rod bearings.

**NOTE** — A 5 to 8 micron filter with red inscriptions is fitted to new or service exchange engines. It is also furnished with piston and liner sets. This filter must be replaced with a Purflux LS 410 (10-15 micron) at the 1,000 mile (1500 km) inspection.

**Crankcase Capacity** — 6.3 qts.

**Normal Oil Pressure** — 29 psi (2 kg/cm<sup>2</sup>) @900 RPM; 64-81 psi (4.5-5.7 kg/cm<sup>2</sup>) @4,000 RPM.

## ENGINE COOLING

### ENGINE COOLING SYSTEM

Pressurized system uses viscous drive type fan. An additional electric fan is used on vehicles equipped with automatic transmission.

**Cooling System Capacity** — 11 qts.

### WATER PUMP

1) Remove intake manifold as in CYLINDER HEADS and disconnect hoses at pump. Remove water pump-alternator drive belt and water pump securing bolts. Remove bolts securing water casings to block and remove water pump-casing assembly.

2) Install new "O" rings using sealing compound at water casing connections. Reinstall water pump and casing, then continue assembly in reverse order of disassembly.

## ENGINE SPECIFICATIONS

GENERAL SPECIFICATIONS										
Year	Displ.		Carburetor	HP at RPM	Torque (Ft. Lbs. at RPM)	Compr. Ratio	Bore		Stroke	
	cu. ins.	cc					in.	mm	in.	mm
1979	174	2849	①	133@5250	163@3000	8.2:1	3.59	91	2.87	73

① — Solex 34 TBIA Single-barrel Primary; Solex 35 CEEI Two-barrel Secondary.

# Peugeot Engines

## 604 GASOLINE V6 (Cont.)

VALVES							
Engine & Valve	Head Diam. In. (mm)	Face Angle	Seat Angle	Seat Width In. (mm)	Stem Diameter In. (mm)	Stem Clearance In. (mm)	Valve Lift In. (mm)
2849 cc Intake	1.73 (44)	30°	30°	.....	.315 (8)	.....	.....
Exhaust	1.46 (37)	45°	45°	.....	.315 (8)	.....	.....

CRANKSHAFT MAIN & CONNECTING ROD BEARINGS							
Engine	MAIN BEARINGS				CONNECTING ROD BEARINGS		
	Journal Diam. In. (mm)	Clearance In. (mm)	Thrust Bearing	Crankshaft End Play In. (mm)	Journal Diam. In. (mm)	Clearance In. (mm)	Side Play In. (mm)
2849 cc	2.7576-2.7583 (70.043-70.062)	.....	Rear	.0028-.0106 (.07-.27)	2.0589 (52.296)	.....	.....

TIGHTENING SPECIFICATIONS	
Application	Ft. Lbs. (mkg)
Cylinder Head .....	See Text
Main Bearing Caps .....	See Text
Connecting Rod Nuts .....	34 (4.75)
Crankcase Peripheral Bolts .....	13 (1.75)
Lower Sump .....	9 (1.3)
Baffle Plate & Strainer .....	9 (1.3)
Flywheel Bolts .....	33 (4.5)
Camshaft Thrust Flange .....	9 (1.3)
Exhaust Manifold Nuts .....	13 (1.75)
Intake Manifold Bolts .....	9 (1.3)
Oil Pump Mounting Bolts .....	9 (1.3)
Oil Pump Sprocket Bolts .....	5 (.6)
Timing Cover Bolts .....	9 (1.3)
Crankshaft Pulley .....	123 (17)
Water Pump Mounting Bolts .....	13 (1.75)
Water Casing Bolts .....	9 (1.3)
Bell Housing Bolts .....	29 (4)