

504 DIESEL 4 CYLINDER

ENGINE CODING

ENGINE IDENTIFICATION

Engine number is stamped on left side of engine block just below cylinder head. XD 2 engine numbers are 3500000-4400000.

ENGINE & CYLINDER HEAD

ENGINE

Removal — 1) Remove hood, battery and battery tray. Remove radiator expansion tank, air filter and intake pipe on vacuum pump. Disconnect upper and lower radiator hoses and upper and lower radiator mountings. Disconnect fan wiring and remove fan and radiator.

2) Disconnect injector pump controls, fuel inlet and fuel outlet lines. Remove heater hose return line. Disconnect starter, oil pressure switch, pre-heat circuit and thermistor wiring. Remove starter.

3) Disconnect alternator wiring and air conditioner hose from cylinder head. Disconnect exhaust pipe at manifold and remove right engine support nut. From left side of engine, disconnect clutch housing sealing plates, upper clutch housing-to-block bolt and left engine support nut.

4) Disconnect exhaust pipe support bracket from transmission. Remove right clutch housing cover plate. Install suitable engine lifting device and raise engine until transmission contacts tunnel. Support transmission.

5) Remove two lower clutch housing-to-block bolts. Carefully move engine forward to clear transmission shaft and lift up to remove from vehicle.

Installation — To install, reverse removal procedure and note: Coat splines of main shaft with Molykote 321 (or equivalent). Install and tighten all clutch housing-to-block bolts before removing transmission support.

CYLINDER HEAD

CAUTION — Cylinder head bolts must not be loosened while engine is warm.

Removal — 1) Drain cooling system. Remove air filter, hose to expansion tank and upper radiator hose. Remove vacuum hose, vacuum pump and belt, idler puller, and water pump belt.

2) Disconnect air conditioner line, and rocker shaft oil line union (located over center intake manifold port). Disconnect exhaust pipe at manifold. Disconnect injector feed lines and remove return lines. Disconnect pre-heat electrical connections at cylinder head.

CAUTION — Do not lose washer (seal) at oil inlet-to-cylinder head connection.

3) Remove rocker arm cover and rocker arm assembly. Remove push rods, taking care not to disturb tappets, and set aside in original order for proper installation.

4) Remove one bolt at each end of cylinder head and replace with suitable guide stands. Remove injection holders and injectors. Remove remaining head bolts and remove cylinder head.

Installation — 1) Measure amount of piston protrusion and select appropriate gasket. Install new dry gasket with large crimped side facing cylinder block. Place cylinder head over guides and install bolts. Note that 8 short bolts are installed on injector side, 7 medium length bolts on manifold side and 6 long bolts in center. Special ground connecting bolt may be installed in No. 19 position.

2) Tighten cylinder head bolts in first step to 33 ft. lbs. (4.5 mkg) in sequence shown in illustration. In second step, tighten in sequence to 47 ft. lbs. (6.5 mkg). Second step must be done one bolt at a time in sequence, loosening $\frac{1}{4}$ turn and retightening to 47 ft. lbs. (6.5 mkg). Install injector holders (with new seals), injector shields and washers. Install push rods in original position and install rocker arm assembly. See *Rocker Arm Assembly* in this article.

NOTE — Do not forget washer (seal) at oil inlet-to-cylinder head connection.

3) Adjust valves to .010" (.25 mm) for intake and .014" (.35 mm) for exhaust. See *Valve Clearance Adjustment*. After 600 miles, adjust valves to standard clearances.

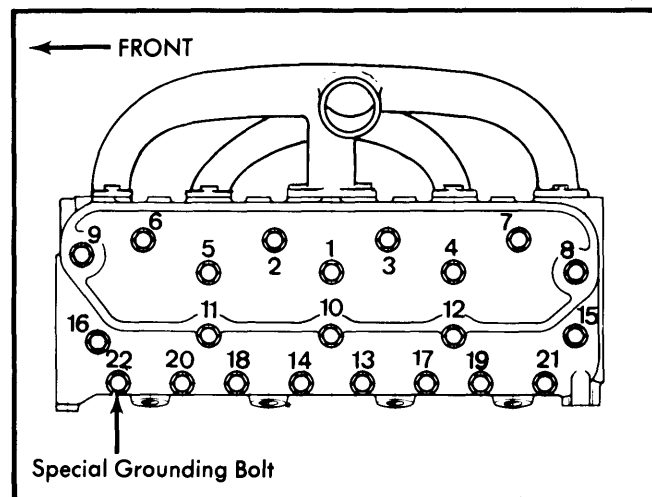

Fig. 1 Cylinder Head Bolt Tightening Sequence

NOTE — Cylinder head bolts MUST be retightened after 30 miles and again after 600 miles. Engine must be allowed to cool for 6 hours before retightening bolts. To retighten bolts, loosen bolts in sequence $\frac{1}{4}$ turn, then retighten to 47 ft. lbs. (6.5 mkg). Operation must be performed 2 times.

VALVES

VALVE ARRANGEMENT

I-E-I-I-I-E-I (Front to Rear).

NOTE — Cylinders and valves are numbered with number one at flywheel end.

Peugeot Engines

504 DIESEL 4 CYLINDER (Cont.)

VALVE DEPTH

After cylinder head has been resurfaced or valve seats ground or replaced, depth of valve face beneath cylinder head surface must be checked. Measure depth with dial gauge. Depth must be .030-.045" (.75-1.15 mm). If too shallow, regrind valve seats. If too deep, replace valves and/or valve seats.

ROCKER ARM ASSEMBLY

1) To remove rocker arm assembly, remove rocker arm cover and remove rocker shaft support bolts. Lift rocker arm assembly noting oil line union sealing washer.

2) To disassemble rocker arm assembly, remove end shaft supports and remove rocker arms, supports, springs and washers. Remove locating screw on lubrication fitting, then remove shaft.

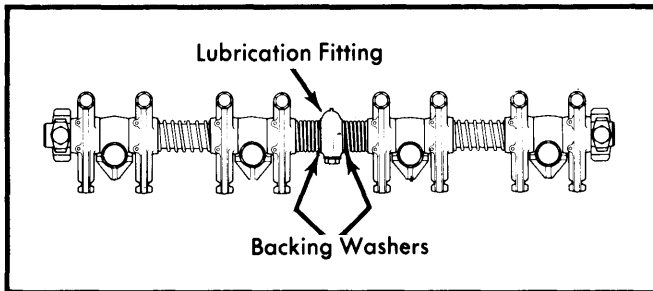

Fig. 2 Assembled View of Rocker Arm Assembly with Oil Holes Detailed

3) Check shaft diameter at areas where rocker arms contact shaft. Minimum diameter of shaft is .746" (18.95 mm). Replace shaft and/or rocker arms if excessive wear or scoring is evident.

4) To assemble rocker arm assembly, slide rocker shaft into lubrication fitting noting that oil holes in shaft are on same side as screw hole in fitting. Line up screw hole in shaft with threaded hole in fitting and install locating screw and copper washer.

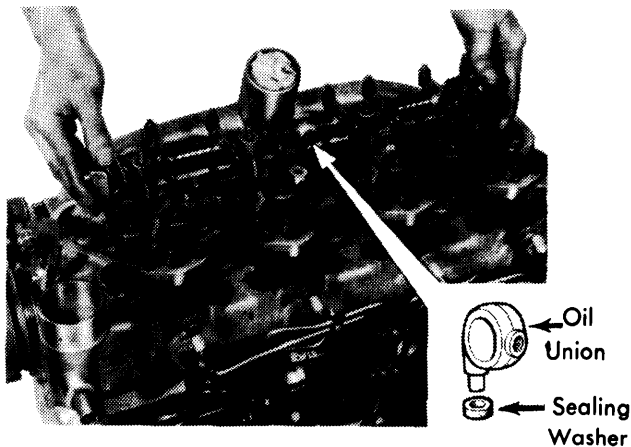

Fig. 3 Installing Rocker Arm Assembly to Cylinder Head

5) Lubricate rocker shaft and install washers, springs, rocker arms and rocker supports. Install shims .004" (.10 mm) thick between outer rocker arms and end supports, then install oil union washer (seal).

6) Install rocker shaft assembly on cylinder head and tighten shaft support bolts. After all bolts are tightened, remove shims and check that all rocker arms operate smoothly.

VALVE CLEARANCE ADJUSTMENT

NOTE — Engine must be allowed to cool at least six hours before adjusting valves.

Rotate engine until exhaust valve number one is fully opened, then adjust intake valve number three and exhaust number four. Rotate engine one half turn until next number valve is fully opened and adjust corresponding valves. See table. Continue until all valves have been adjusted.

Valve Adjustment Sequence

Valve Open	Adjust Valves
E 1.....	I 3 & E 4
E 3.....	I 4 & E 2
E 4.....	I 2 & E 1
E 2.....	I 1 & E 3

Valve Clearance Adjustment

Application ①	Intake In. (mm)	Exhaust In. (mm)
New Head Gasket010 (.25)	.014 (.35)
Stand. Adjust.006-.008 (.15-.20)	.010-.012 (.25-.30)

① — Adjust valves to standard adjustment 600 miles after installing new head gasket and retightening cylinder head bolts.

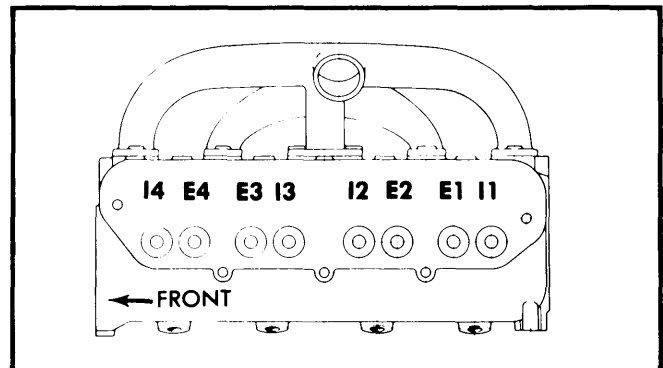

Fig. 4 View of Intake and Exhaust Valve Arrangement

COMBUSTION (SWIRL) CHAMBERS

Removal — Remove cylinder head from vehicle and remove injectors, injector studs, rocker arms, rocker arm mounting studs, manifolds and glow plugs. Using suitable drift (see illustration) carefully drive swirl chambers down and out of cylinder head. Tap drift LIGHTLY so as not to damage inner face of chamber.

504 DIESEL 4 CYLINDER (Cont.)

CAUTION — If the swirl chamber twists and/or sticks in its bore, turn head over, tap chamber back into place with soft mallet, and start over again.

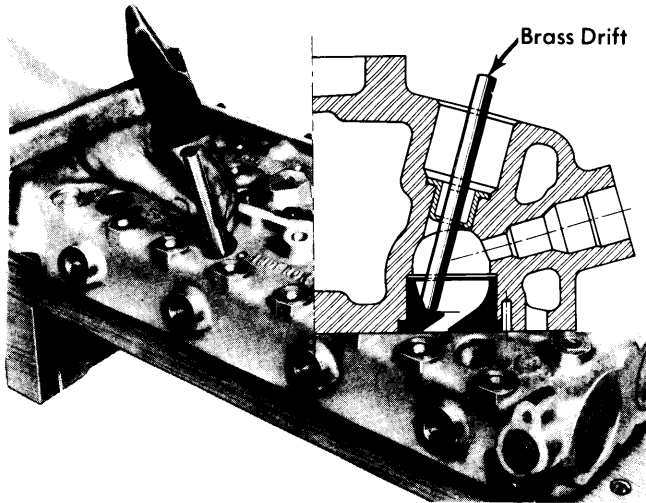

Fig. 5 Removing Combustion Chamber with Hammer and Drift

Inspection — 1) Inspect swirl chambers for distortion and cracks. Small cracks around the gas outlet are acceptable and do not effect engine operation. Replace all doubtful chambers. Measure thickness of shoulder and overall height of chamber.

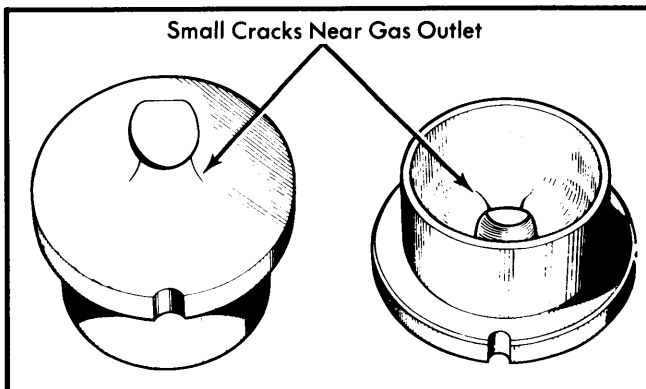

Fig. 6 View Showing Acceptable Cracks in Combustion Chamber

2) Place suitable truing punch (0.0139) over chamber bore in cylinder head, making sure dowel pin in punch is correctly located in head. Tap truing punch to make sure shoulder surface of bore is parallel with cylinder head. Slightly chamfer the edges of the chamber bore.

3) Measure depth of bore and depth to shoulder. Swirl chamber should protrude from cylinder head surface .000-.001" (.00-.03 mm) and clearance from swirl chamber to bottom of chamber bore should be .004-.020" (.10-.50 mm). To adjust clearances, chamber may be machined on shoulder surface and on bottom surface. Never machine face of chamber.

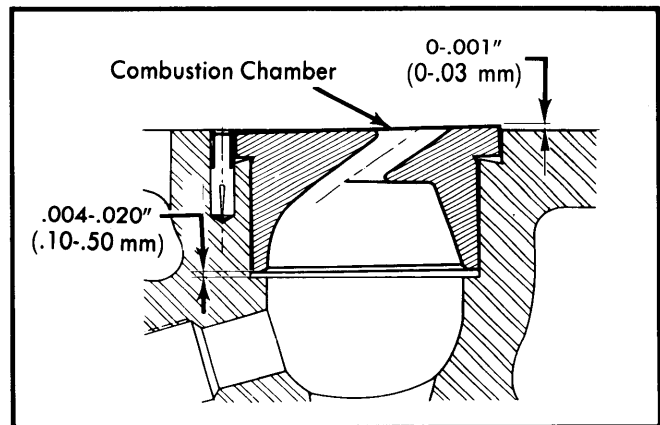

Fig. 7 Cross-Sectional View Showing Combustion Chamber Clearance and Protrusion

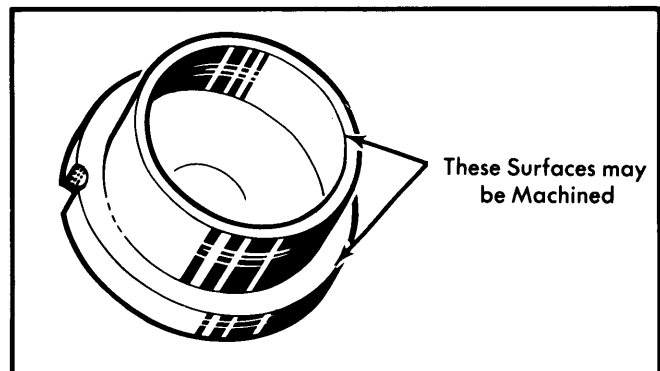

Fig. 8 Combustion (Swirl) Chamber with Detail of Machinable Surfaces

Installation — 1) Insert new wedge pins into the cylinder head and using chamfered drift, drive pins .028" (.7 mm) below cylinder head surface. Carefully insert the swirl chambers in the original bores and lightly tap into place with soft mallet.

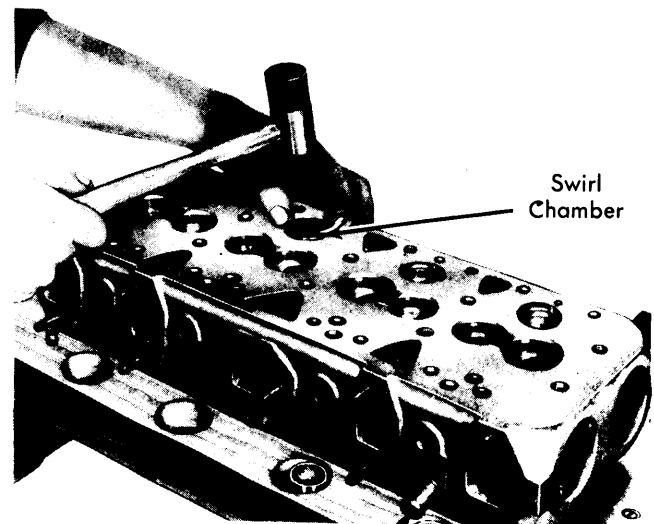

Fig. 9 Installing Combustion (Swirl) Chambers

504 DIESEL 4 CYLINDER (Cont.)

2) Check for tight fit. If chamber is loose, chamber recess must be bored for oversize chamber. Using a dial gauge, check protrusion and parallelism with the cylinder head. Protrusion must be .000-.001" (.00-.03 mm) and difference between any two points must not exceed .001" (.03 mm).

PISTONS, PINS & RINGS

PISTON, LINER & ROD ASSEMBLY

1) Remove engine from vehicle and drain oil. Remove oil pan, oil pump and cylinder head. Mark connecting rods for replacement in original location and remove connecting rod caps.

2) Push pistons up through top of cylinder block and replace connecting rod caps so they do not become mixed. Remove piston pin circlip and remove piston pin.

NOTE — *Pistons, pins and rings are matched at factory and must not be intermixed.*

3) Clean new piston assemblies with trichlorethylene. Do not remove piston rings to clean pistons. Make sure all protective coating has been removed from ring grooves. Blow with compressed air and check that piston rings move freely in grooves.

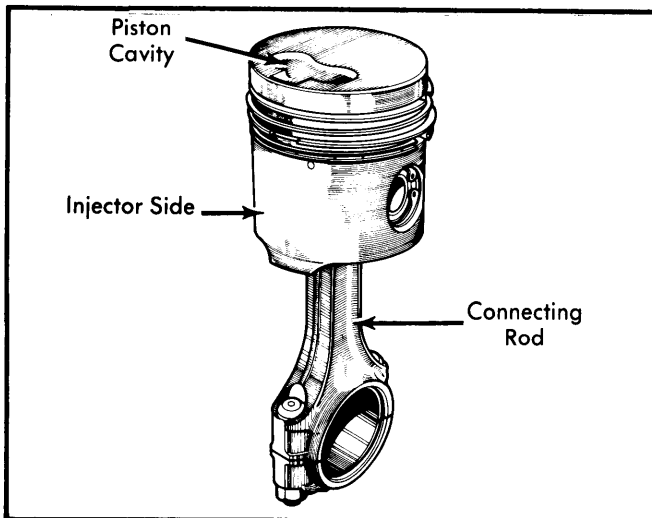

Fig. 10 Assembled View of Piston and Connecting Rod

4) Check fit of piston pin in connecting rod small end bushing. Ream bushing if too tight and replace bushing if too loose. Remove circlip from piston and partially remove piston pin. Position piston and rod so cavity on piston and reference marks on rod are on same side. Lubricate pin and install in piston. Replace circlip.

5) Lubricate pistons and bearings. Using suitable ring compressor, install each piston in its respective cylinder bore with cavity in piston facing injector side of engine. Install new rod cap nuts and bolts.

NOTE — *Standard-size pistons have an "A" or "B" stamped on top surface. Match pistons to cylinder bores, which have an "A" or "B" stamped on side of cylinder block adjacent to each bore. See Fig. 11. Oversize pistons are stamped with either a "C" or "D", depending upon size class.*

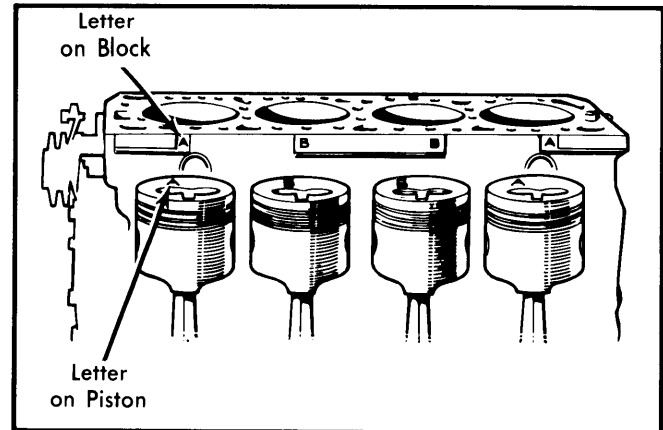

Fig. 11 Matching Pistons to Cylinder Bores

CRANKSHAFT MAIN & CONNECTING ROD BEARINGS

MAIN BEARINGS

Bearing caps are installed with the reference mark on injector side. Main bearing cap number two (as numbered from flywheel end) and number four are nearly identical. Bearing cap number two can be identified by letter after the part number.

THRUST BEARING ALIGNMENT

Thrust washers are located on both sides of center main bearing. Measure end play and replace washers as required. Thrust washers are available in standard thickness .091-.092" (2.30-2.33 mm) and oversize .098-.100" (2.50-2.53 mm). Install washers with oil grooves toward crankshaft.

REAR MAIN BEARING OIL SEAL

1) Crankshaft must be removed to replace oil seal. Work seal packing manually into cylinder block and into bearing cap grooves. Place seal forming mandrel (8.0110) onto packing and form packing into groove by tapping mandrel with a hammer.

2) Make sure packing is correctly seated in its groove without being crushed (see illustration). Cut seal packing clean flush with mating surface and follow same procedure for bearing cap.

3) Place side seals in grooves of bearing cap and hold seals into place with suitable shim tool (8.0110 CZ & 8.0110 BZ). Lubricate shims and bring into place in cylinder block, tapping down with hammer handle. Install and tighten bearing cap bolts and check that bearing cap has seated properly. Trim side seals with knife so that they protrude .002" (.05 mm) above lower crankcase mating surface.

504 DIESEL 4 CYLINDER (Cont.)

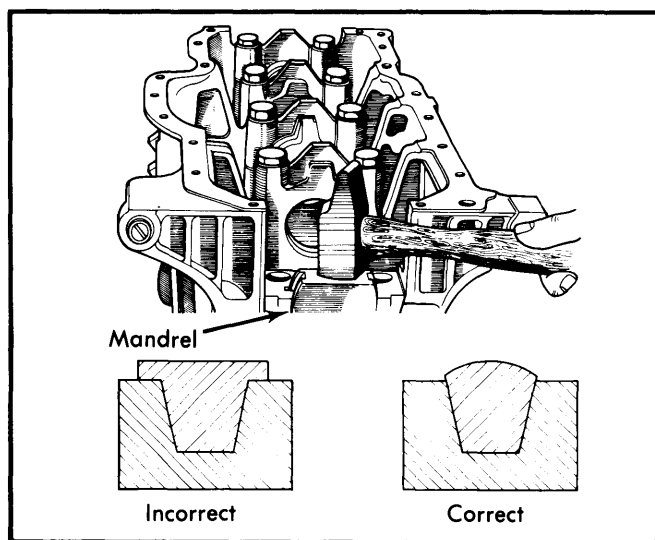

Fig. 12 Using a Mandrel and Mallet to Install Upper Rear Main Oil Seal

CAMSHAFT

TIMING CHAIN

Removal — With engine removed, remove oil pan and front engine cover. Remove plug from timing chain tensioner and release chain tensioner by inserting 3 mm Allen wrench, turning clockwise. Loosen idler gear fastening nut and move idler gear to slack position by turning eccentric. Remove bolts from injection pump gear and remove gear and timing chain.

Installation — 1) Check end play of injection pump support bearing. End play should be .002-.037" (.06-.94 mm). If engine front plate has been removed, lock countersunk screw with two punch marks. Position crankshaft gear timing mark down and camshaft gear mark at 11 o'clock position. See Fig. 13.

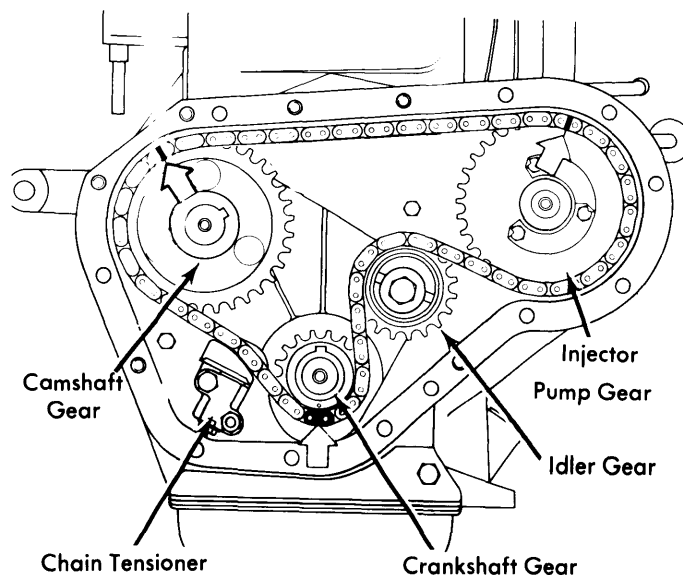

Fig. 13 Timing Chain Installed to Illustrate Timing Mark Alignments

2) Install chain on injection pump gear aligning line on link with mark on gear. Install chain with pump gear onto camshaft and crankshaft sprockets, taking care to align copper link on chain with timing mark on crankshaft gear and link marked with line aligned with the line on camshaft gear. Install locating dowel in injection pump gear.

NOTE — Crankshaft timing gears are available in 3 types. If any component part of timing gear has been replaced, crankshaft timing gear must be replaced with a 3-dot gear. ONLY gears with 1 or 3 reference dots can be used for repair.

3) Adjust the idler gear eccentric by rotating eccentric counterclockwise until clearance between tensioner head and body is .020-.040" (.50-1.00 mm). Tighten idler gear fastening nut, then adjust tensioner by turning Allen wrench to right until tensioner head is pushing on chain. Install and lock tensioner plug.

CAMSHAFT

Removal — With timing chain removed, remove camshaft thrust plate bolts, gaining access through holes in camshaft gear. Carefully pull camshaft from cylinder block.

Installation — If gear was removed from camshaft, heat camshaft gear in well heated oil. Install thrust plate on camshaft, then install shaft key and press gear into place, leaving clearance of .002-.006" (.05-.15 mm) between thrust plate and gear hub. Install camshaft in block and tighten thrust plate bolts. Check camshaft end play, a specification of .002-.006" (.05-.015 mm) should be obtained.

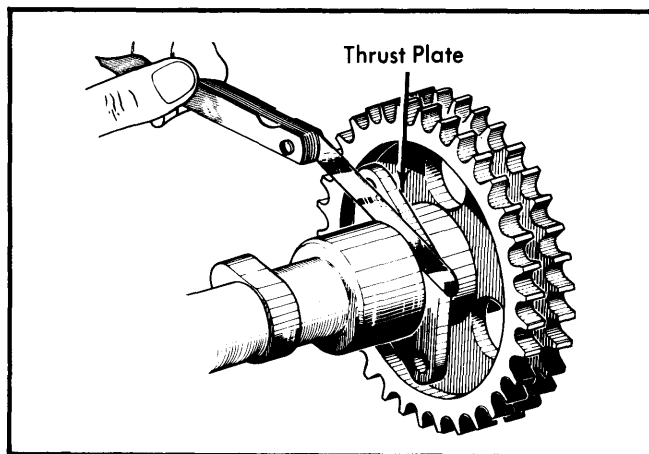

Fig. 14 Measuring Camshaft Thrust Plate Clearance

VALVE TIMING

1) With all valve components assembled and cylinder head installed, remove injectors or glow plugs to relieve compression. Adjust valves to correct clearance. See Valve Clearance Adjustment.

Peugeot Engines

504 DIESEL 4 CYLINDER (Cont.)

2) Place a .016" (.40 mm) feeler gauge between rocker arm and intake valve stem of each cylinder in succession. Rotate engine by hand to determine if there is contact between valve and piston at beginning of intake valve opening. If contact is felt, replace crankshaft timing gear with a gear having one timing reference mark.

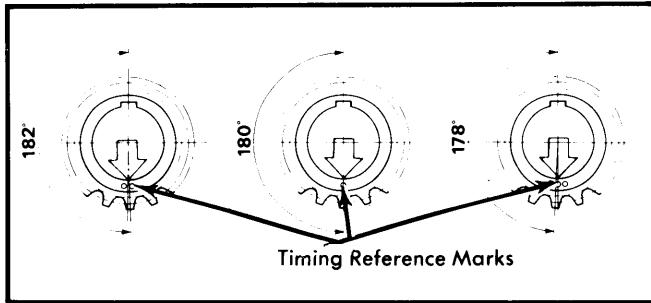

Fig. 15 Crankshaft Timing Gears Available

ENGINE OILING

- Crankcase Capacity** — 5.29 qt.
- Oil Filter** — Full flow cartridge type.
- Pressure Regulator Valve** — Located in oil pump.
- Normal Oil Pressure** — Minimum at idle, 22 psi (1.6 kg/cm²); at 4000 RPM, 42-58 psi (3-4.1 kg/cm²).

ENGINE OILING SYSTEM

A high output, gear type oil pump, driven by camshaft, is mounted in oil pan.

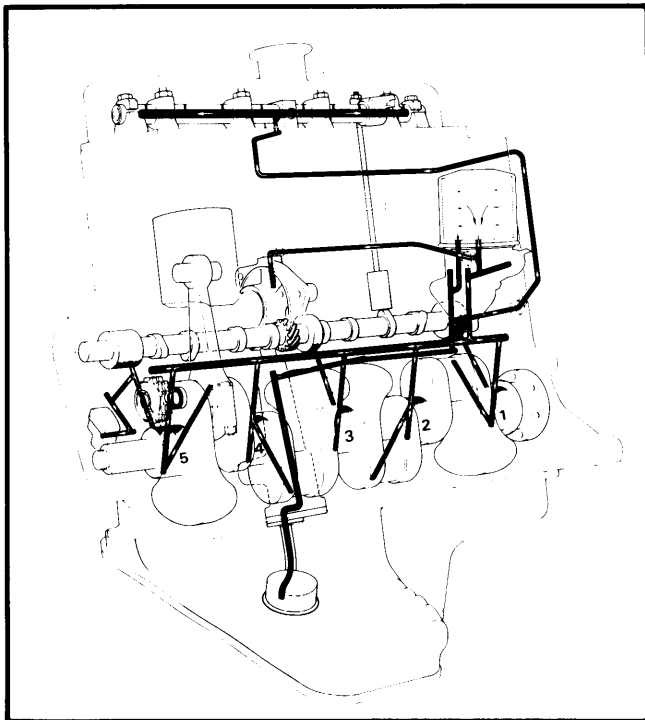

Fig. 16 Sectional View of Diesel Engine Oiling Circuit

OIL PUMP

Whenever the oil pump or oil feed tube has been removed or repositioned, oil feed tube must be adjusted. With oil pump installed, bottom of oil feed tube must extend 3.03" (77 mm) below cylinder block mating surface. After adjusting, oil feed tube, install strainer ensuring thrust washer is under spring tension.

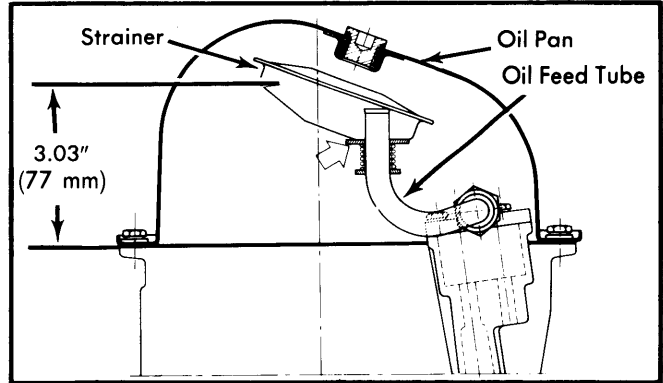

Fig. 17 Oil Pump Feed Tube Installation (Pan Inverted)

ENGINE COOLING

- Thermostat** — Begins opening at 162°F (72°C), fully open at 184°F (84°C).
- Cooling System Capacity** — 10.57 qt.

WATER PUMP

- 1) Remove radiator, top hose, and fan belt. Disconnect heater hose from pump and the self-disengaging fan brush holder. Remove water pump.
- 2) To install, reverse removal procedures, noting the following: clean contact surfaces before installing new gasket.

SELF-DISENGAGING FAN

Driven by water pump shaft and controlled by a thermal contact-breaker. Fan engages at 178-182°F (81-83°C) and disengages at 151-158°F (66.5-70°C).

TIGHTENING SPECIFICATIONS

Application	Ft. Lbs. (mkg)
Cylinder Head	See Text
Clutch Housing-to-Block	43 (6.0)
Rocker Arm Supports	
End Supports.....	14 (2.0)
Center Supports.....	36 (5.0)
Connecting Rod Caps	42 (6.0)
Main Bearing Caps.....	72 (10)
Timing Chain Idler Gear	36 (5.0)
Crankshaft Pulley	130-195 (18-27)
Flywheel Bolts	47 (6.5)
Glow Plugs	33 (4.5)
Manifolds	11 (1.5)
Injector Flanges	11 (1.5)

Peugeot Engines

5-213

504 DIESEL 4 CYLINDER (Cont.)

ENGINE SPECIFICATIONS

GENERAL SPECIFICATIONS										
Year	Displ.		Carburetor	HP at RPM	Torque (Ft. Lbs. at RPM)	Compr. Ratio	Bore		Stroke	
	cu. ins.	cc					in.	mm	in.	mm
1979	140.6	2304	Fuel Inj.	71@4500	99@2500	22.5:1	3.700	94	3.267	83

VALVES							
Engine & Valve	Head Diam. In. (mm)	Face Angle	Seat Angle	Seat Width In. (mm)	Stem Diameter In. (mm)	Stem Clearance In. (mm)	Valve Lift In. (mm)
2304 cc Intake	1.594 (40.5)	30°	30°3336-.3344 (8.473-8.495)	.0018 (.047)	.243 (6.173)
Exhaust	1.319 (33.5)	45°	45°3328-.3337 (8.453-8.475)	.0026 (.067)	.243 (6.173)

PISTONS, PINS, RINGS						
Engine	PISTONS	PINS		RINGS		
	Clearance In. (mm)	Piston Fit In. (mm)	Rod Fit In. (mm)	Rings	End Gap In. (mm)	Side Clearance In. (mm)
2304 cc	.005-.006 (.13-.16)	Press Fit	No. 1 No. 2 Oil	.014-.024 (.35-.60) .014-.024 (.35-.60) .006-.012 (.16-.30)

CRANKSHAFT MAIN & CONNECTING ROD BEARINGS							
Engine	MAIN BEARINGS				CONNECTING ROD BEARINGS		
	Journal Diam. In. (mm)	Clearance In. (mm)	Thrust Bearing	Crankshaft End Play In. (mm)	Journal Diam. In. (mm)	Clearance In. (mm)	Side Play In. (mm)
2304 cc	2.1651-2.1661 (54.994-55.021)	.002-.004 (.05-.10)	Center	.003-.011 (.08-.29)	1.9678-1.9689 (49.984-50.011)	.002-.004 (.05-.10)

VALVE SPRINGS			
Engine	Free Length In. (mm)	PRESSURE Lbs. @ In. (kg @ mm)	
		Valve Closed	Valve Open
2304 cc	1.614 (41.0)	16.75 @ (7.6 @)	34.8 @ (15.8 @)

VALVE TIMING				
Engine	INTAKE		EXHAUST	
	Open (BTDC)	Close (ABDC)	Open (BBDC)	Close (ATDC)
2304 cc	40°	28°	43°	1°