

MGB 4 CYLINDER

ENGINE CODING

ENGINE IDENTIFICATION

Engine identification and serial number are stamped on a plate secured to right side of engine just below spark plugs. Engine can also be identified by the second digit of the VIN code. Second digit should be an H.

Engine Identification	
Application	Code
Federal	
Without Overdrive	18V 883
With Overdrive	18V 884
Calif.	
Without Overdrive	18V 890
With Overdrive	18V 891

NOTE — VIN number prefix for 1979 MGB is GHN5UL.

ENGINE, CYLINDER HEAD & MANIFOLDS

ENGINE

NOTE — Remove engine and transmission as an assembly.

Removal — 1) Disconnect battery. Remove hood. Drain engine oil and cooling system. Disconnect oil pressure line at block. Disconnect oil cooler lines from engine at filter. Disconnect all coolant hoses and remove radiator.

2) Disconnect alternator and distributor wires, then remove distributor cap. Place heater valve out-of-way. Disconnect pre-heater and temperature sender wires. Remove air cleaner.

3) Disconnect throttle cable and fuel inlet line at carburetor. Take off purge hose at rocker cover. Disconnect fuel evaporation canister lines. Disconnect both power brake vacuum and anti-diesel vacuum lines. Remove shifter lever.

4) Disconnect back-up lights, overdrive, and starter wiring. Remove wiring from clips. Separate clutch slave cylinder from clutch housing. Disconnect speedometer cable. Disconnect exhaust at manifold. Remove propeller shaft. Remove engine restraint rod.

5) Remove 4 bolts holding rear mounting crossmember to chassis and allow transmission to drop to fixed crossmember. Remove bolts mounting bracket (in middle of crossmember) to crossmember. Remove nuts holding rear mounts to crossmember; then remove crossmember. Take up weight of vehicle, free front motor mounts, and lift out engine/transmission assembly.

Installation — To install engine/transmission assembly, reverse removal procedure.

INTAKE & EXHAUST MANIFOLDS

Removal — 1) Drain cooling system. Remove air cleaner. Disconnect fuel evaporation hose at carburetor. Disconnect heater line from bottom radiator hose. Disconnect wire from pre-heater.

2) Remove carburetor (4 nuts) with pre-heater components. Disconnect brake unit vacuum hose, anti-diesel valve hose, and gulp valve hose. Remove gulp valve and swing out-of-way.

3) Remove hot air shroud. Separate exhaust pipe from bracket at front mount. Separate pipe at manifold. Remove manifold mounting nuts and bolts and lift off manifold assembly.

Installation — To install, reverse removal procedure and note: Attach exhaust pipe to manifold before tightening to mounting bracket.

CYLINDER HEAD

Removal — 1) Drain cooling system. Disconnect radiator hose at thermostat housing. Disconnect carburetor vent line and anti-diesel line. Remove hose secured to thermostat housing. Disconnect purge hose at rocker cover.

2) Free automatic choke water hose. Disconnect gulp valve, air pump, and check valve hoses. Remove necessary air pump bolts. Disconnect spark plug, temperature sender, and pre-heater wires.

3) Place heater valve out-of-way. Remove hose from water pump. Remove air cleaner assembly. Free hot air shroud. Slide shroud back and remove manifold.

4) Remove rocker shaft and withdraw push rods. Remove AIR manifold rail. Do not remove check valve. Remove cylinder head nuts making note of nut mounting AIR manifold. Lift off head.

Installation — To install, reverse removal procedure and note: New gasket is marked "TOP" and "FRONT". Top must face up and front must face water pump.

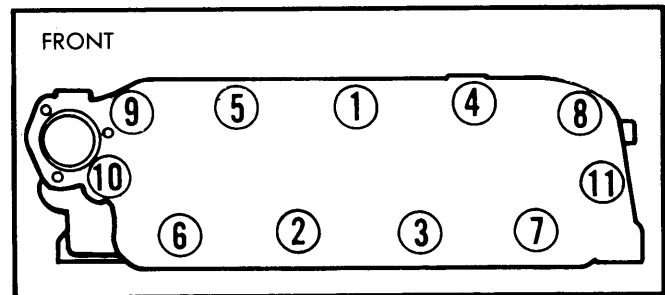

Fig. 1 MGB Cylinder Head Tightening Sequence

VALVES

VALVE ARRANGEMENT

E-I-I-E-E-I-I-E (front to rear)

VALVE GUIDE SERVICING

1) Remove cylinder head and valves. Rest cylinder head with machined face downward on a clean surface. Drive valve guide downwards into combustion chamber space with a suitable drift. When installing new guides, they must be driven in from top of cylinder head.

2) Guides must be inserted with end having largest chamfer at top. Guides should be driven into combustion chamber until exhaust valve guides are 5/8" and intake valve guides are 3/4" above machined surface of valve spring seating.

MGB 4 CYLINDER (Cont.)

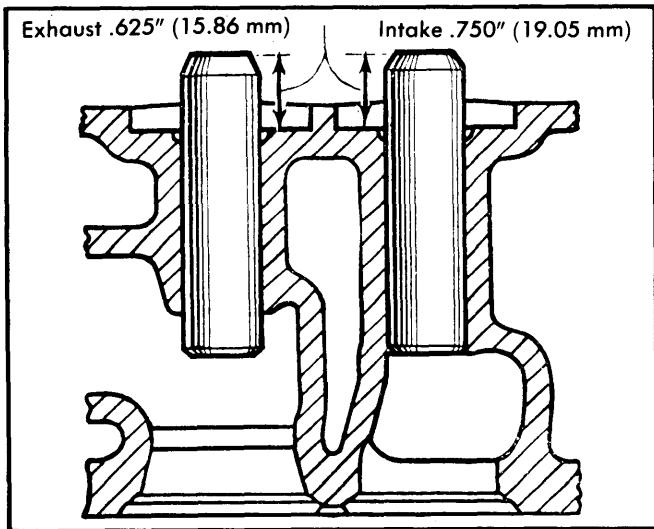

Fig. 2 Cross Sectional View of Installed Valve Guide

VALVE SPRINGS

Removal — Remove cylinder head and rocker arm assembly. Compress springs using suitable tool (18G45). Remove two valve keepers. Release valve springs and remove compressor. Take out valve spring retainer, spring, and bottom retainer. Remove "O" ring seal from groove and remove valve from guide.

Installation — Reverse removal procedure using new valve "O" ring seals. Soak rings in clean engine oil for a short time before use to ease installation.

ROCKER ARM ASSEMBLY

Removal — 1) Drain cooling system and disconnect breather pipe from rocker cover. Remove throttle cable, remove two rocker cover attaching nuts and lift off rocker cover. Take care not to damage cork gasket or lose washers or rubber seals.

2) Notice that under the right rear rocker stud nut there is a locking plate. Unscrew eight rocker shaft bracket nuts and external cylinder head nuts gradually, one turn at a time, until all load is released.

NOTE — It is important that external cylinder head nuts are loosened at same time to avoid possibility of head distortion and water entering cylinders.

3) Remove all rocker shaft bracket nuts and remove rocker assembly, complete with brackets and rockers. Remove push rods, arranging them so they may be replaced in same positions.

Disassembly 1) — Remove set screw locating rocker shaft in rear rocker mounting bracket, then remove cotter pins, flat washers and spring washers. Slide rockers, brackets, and springs off shaft. Make sure to note how components come off so they can be reassembled accurately.

2) Using suitable tool (18G226), place rocker on anvil and drive out worn bushing. Place new bushing on driver and position bushing with butt joint at top of rocker bore and oil groove in bushing at bottom of rocker bore.

3) It is necessary to drill oil holes in bushing to coincide with oilways in rocker. Holes may be drilled either before or after installation.

4) If holes are drilled after installation, remove adjuster screw and use .093" (2.36 mm) drill to extract end plug and to continue oilway through bushing.

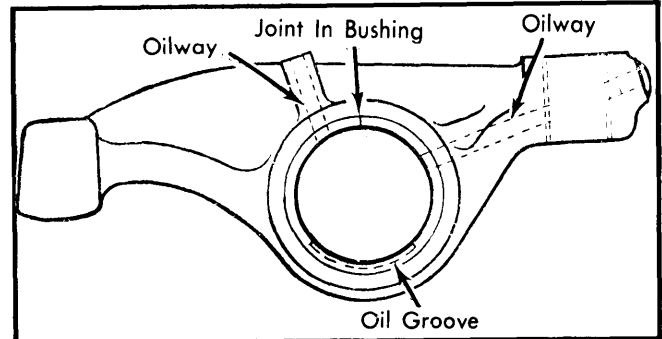

Fig. 3 Rocker Arm Bushing with Detail of Oil Holes

5) Replug end after operation using a rivet and weld rivet into position. Oil hole in top of rocker barrel must continue through the bushing with a No. 47 drill. Finally, burnish ream bushing to .6255-.6260" (15.89-15.90 mm).

Reassembly — Reverse disassembly procedure. Remember to replace rocker shaft locating screw lock plate.

Installation — To install rocker assembly on cylinder head, reverse removal procedure. Make sure cylinder head bolts are retorqued before installing rocker cover.

VALVE TAPPETS

Removal — Remove manifolds. Remove rocker shaft. Withdraw push rods and keep in order. Loosen clamp and separate hose from neck attached to tappet cover. Remove side covers and gaskets. Take out tappets keeping them in order.

Installation — To install valve tappets, reverse removal procedure and note: Tappets should seat without forcing.

VALVE CLEARANCE ADJUSTMENT

Remove valve cover and observe operation of valves. To check clearances, turn crankshaft until valves in the first column of table are fully open. Then, valves in second column may be checked and adjust to .013" (.33 mm). Set clearance with engine warm.

Valve Adjustment Sequence

Valves Open	Valves to Adjust
1	8
3	6
5	4
2	7
8	1
6	3
4	5
7	2

MGB 4 CYLINDER (Cont.)

PISTONS, PINS & RINGS

OIL PAN

1) Drain engine oil and drain coolant. Disconnect radiator hoses and remove engine front mounting bolts. Lift engine enough to gain access to front oil pan bolts.

2) Remove all oil pan bolts and remove oil pan from engine. To install, reverse removal procedure using new oil pan gasket.

PISTONS & RODS

1) Remove cylinder head and oil pan. Pistons and rods must be removed from top of cylinder block. Remove rod nuts and remove bearing caps. Release connecting rods from crankshaft.

2) Remove piston and rod assembly out top of cylinder block and reinstall bearing cap. Connecting rod bearing caps are offset. Make sure that parts are marked so reassembly will be in original position.

PISTON RINGS

1) Place rings in top of cylinder bore. Check ring gaps. Check oil ring to groove clearance. Fit oil control expander. Make sure ends of expander are butting, but not overlapping. Set gaps of rails and expander 90° to each other.

2) Fit stepped compression rings into SECOND groove with face marked "TOP" up. Fit top ring. Place ring gaps 90° to each other away from thrust side of piston.

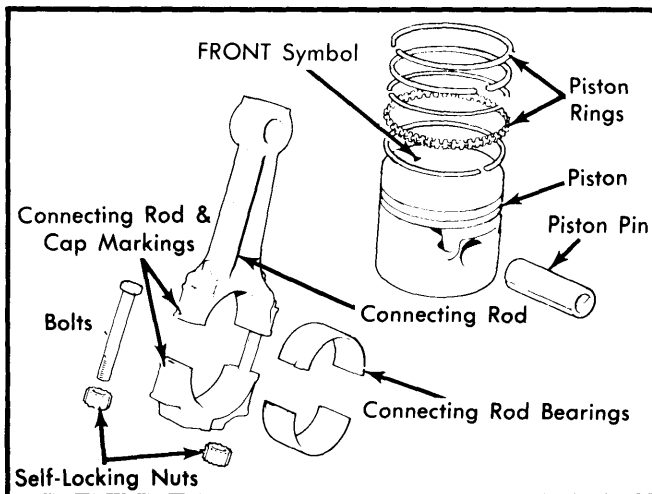

Fig. 4 Exploded View of Piston and Rod Assembly

PISTON PINS

Piston pins are press fit. Use suitable tool or press to remove or install pins.

CRANKSHAFT MAIN & CONNECTING ROD BEARINGS

CRANKSHAFT

Removal – 1) Drain cooling system. Remove engine as previously outlined. Separate transmission from engine.

2) Remove following components from engine:

- Oil pan and oil pump.
- Clutch assembly, flywheel, and transmission adaptor plate.
- Timing cover, tensioner, chain and sprockets.
- Camshaft lock plate.

3) Remove main bearing and connecting rod caps, then take out bearing halves. Remove thrust washers and lift out crankshaft.

Installation – 1) Thoroughly clean out all crankshaft oil passages. Insert top bearing halves in block. Slide crankshaft into bearings.

2) Install thrust washers at rear main bearing with oilways facing away from bearing. Make sure thrust washer tabs locate in slot in main bearing cap.

3) Install bottom bearing halves and main bearing caps. Torque cap bolts.

4) Check crankshaft end play and adjust if necessary with selective fit washers. End play should be as specified in table.

5) Install remaining components in reverse of removal procedure.

CONNECTING ROD BEARINGS

To remove bearings, bend down locking strips so that bolts may be removed. Remove connecting rod caps and extract bearings. No scraping of bearings is required as bearings are machined to give correct clearance of .001-.0027" (.03-.07 mm).

MAIN BEARINGS

1) Remove engine from car and remove flywheel and clutch, timing chain, oil pan and oil strainer. Remove rear engine mounting plate. Remove two bolts and locking plate holding front main bearing cap to engine front plate. Remove main bearing cap retaining nuts and remove caps and bearings.

2) Bearings are machined to give correct clearance of .001-.0027". When replacing bearings that have been used but are not damaged or worn, make sure that bearing and all surfaces are thoroughly cleaned. Rear main bearing cap horizontal joint surface should be lightly covered with Hylomar Jointing Compound or equivalent before cap is fitted to cylinder block. Tighten bearing cap nuts.

THRUST BEARINGS

A thrust washer is fitted on each side of center main bearing to take crankshaft end thrust. Washers each consist of two semicircular halves, one having a lug located in recess in removable half of bearing and other one being plain.

CAMSHAFT

FRONT COVER & OIL SEAL

Removal – Drain cooling system. Remove radiator. Remove alternator belt and A.I.R. pump belt. Remove fan and pulley from crankshaft. Remove front cover bolts and remove from vehicle. Pry or drive out crankshaft oil seal.

MGB 4 CYLINDER (Cont.)

Installation — Dip new oil seal in engine oil. Use installing tool 18G 134 and adapter 18G 134BD to fit seal. Be sure lip of seal is facing inward. Position oil thrower with "F" mark showing. Smear sealing compound on cover and seal. Tighten bolts evenly. Lubricate crankshaft hub and slide pulley on to crankshaft, engaging keyway. Put on new lock nut and tighten bolt.

TIMING CHAIN & TENSIONER

Removal — Remove front cover as previously outlined. Remove oil thrower. Bend back tensioner lock tabs. Remove tensioner bolts. Pry tensioner mechanism out of front plate. Slipper head (piece that rides against chain) is under spring tension. Remove all tensioner components and disassemble any that are not apart. Unlock and remove camshaft nut. Pull off camshaft and crankshaft sprockets.

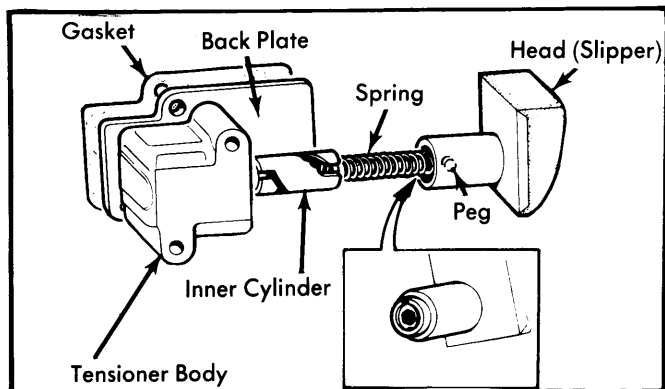

Fig. 5 Exploded View of Timing Chain Tensioner

NOTE — Use care not to lose sprocket packing washers behind crankshaft sprocket. Make sure to replace the same number of washers as removed. To determine correct thickness of washers to be used if new camshaft or crankshaft components have been installed, place straightedge across sides of crankshaft sprocket and measure gap between straightedge and crankshaft sprocket. Select and fit washers as required.

Installation — 1) When replacing timing chain and sprockets, set crankshaft keyway at TDC and camshaft keyway at 2 o'clock position. Assemble sprockets to timing chain with index marks in sprockets (if equipped) opposite each other.

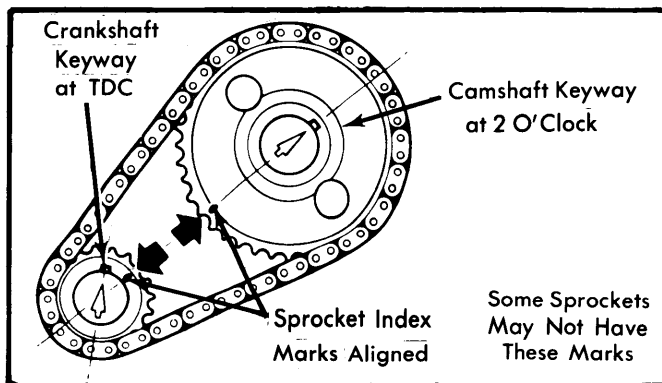

Fig. 6 Camshaft and Crankshaft Sprocket Alignment

2) Keep sprockets in this position and engage crankshaft sprocket keyway with key on crankshaft and rotate camshaft until camshaft sprocket keyway and key are aligned. Push sprockets onto shafts as far as possible and tighten with lock washer and nut.

3) Refit chain tensioner inner cylinder and spring into cylinder of slipper head. Make sure serrated seat in inner cylinder engages peg in slipper cylinder. Turn inner cylinder clockwise against tension until cover serrations in seat engage peg and retains inner cylinder in slipper cylinder. Refit tensioner with mounting bolts. Fit oil thrower with face marked "F" to front. Reverse removal procedure to install remaining components.

CAMSHAFT

Removal & Installation — 1) Disconnect battery and remove intake and exhaust manifolds (if necessary). Remove push rods and tappets. Remove timing cover, timing chain and timing sprockets.

2) Disconnect distributor vacuum line at distributor and remove 2 bolts with flat washers which hold distributor to housing. Do not loosen clamping plate bolt or ignition timing will be disturbed. Remove distributor assembly.

3) Remove oil pan, oil pump, and oil pump drive shaft. Remove 3 set screws and lock washers holding camshaft locating plate to cylinder block. Remove camshaft.

4) Before reassembly, fix camshaft thrust plate and sprocket to camshaft, then check end play. Specifications should not exceed .003-.007" (.076-.178 mm). Make measurement between retaining plate and thrust face of camshaft front journal.

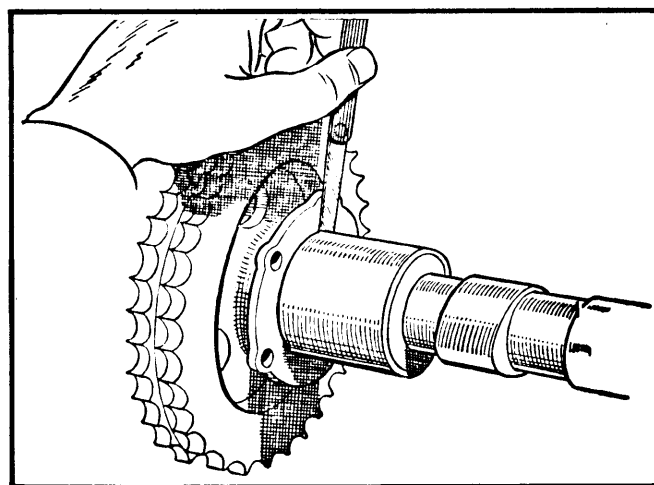

Fig. 7 Using a Feeler Gauge to Measure Camshaft End Play

CAMSHAFT BEARINGS

NOTE — Follow manufacturers instructions for proper adapter and washer use on each bearing for removal and installation.

MGB 4 CYLINDER (Cont.)

Removal — Use bearing removal/installation tool 18G 124A and adapters to remove camshaft front bearing. Remove rear bearing in same manner as front bearing, then index tool through front bearing bore to remove center bearing.

NOTE — Be sure oil holes in new bearings are aligned with lubrication ports in block. The holes must not move once they have been located.

Installation — Fit new bearings into bore in reverse order of removal. After bearings have been installed, use camshaft bearing bore tool 18G 123A to line bore new bearings.

NOTE — Cutting edge of boring tool must be kept dry and free of cuttings at all times.

VALVE TIMING

1) Set No. 1 cylinder intake valve clearance to .055" with engine cold. Turn crankshaft until valve is about to open. Indicator groove in flange of crankshaft pulley should be opposite longest pointer on indicator bracket beneath crankshaft pulley, indicating TDC.

2) After timing has been checked, valve clearance should be reset. See *Valve Clearance Adjustment*.

ENGINE OILING

Crankcase Capacity — 7¼ pints with filter change.

Oil Filter — Full flow type with disposable cartridge.

Oil Pressure — 10-25 psi (.7-1.7 kg/cm²) @idle: 50-80 psi (3.5-5.6 kg/cm²) @2000 RPM.

Oil Pump Relief Valve — Free length is 3" (76.2 mm). Installed length is 2.156" (54.77 mm).

ENGINE OILING SYSTEM

Force feed type with Hobourn-Eaton rotor type oil pump. A full-flow filter is used. An oil pressure relief valve is used to enable oil to by-pass filter if oil filter becomes blocked.

OIL PUMP

Two bolts hold on oil pump cover and 3 studs hold pump to crankcase. To remove pump, remove stud nuts and remove pump and drive shaft. To disassemble, proceed as follows:

1) Remove cover, located at base of oil pump by 2 dowels. Remove outer rotor complete with oil pump shaft. Clean all parts in kerosene and inspect for wear.

2) Rotor end play should be checked as follows: Install rotors in pump body and place straightedge across joint face of pump body. Measure clearance between top face of rotors and underside of straightedge. Clearance should not exceed .005" (.13 mm). If clearance is excessive, remove two cover locating dowels and tap the joint face of pump body.

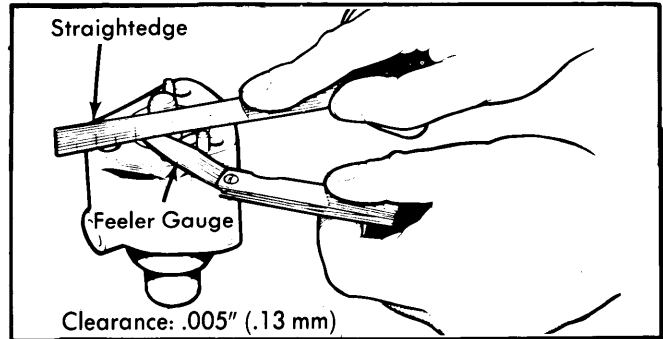

Fig. 8 Measuring Oil Pump Rotor End Play

3) Check clearance between outer rotor and rotor pocket in pump body. If clearance exceeds .010" (.25 mm), pump rotor, pump body, or complete pump assembly should be replaced.

4) Measure clearance of rotor lobes with rotors installed in pump body. If clearance exceeds .006" (.15 mm), rotors must be replaced.

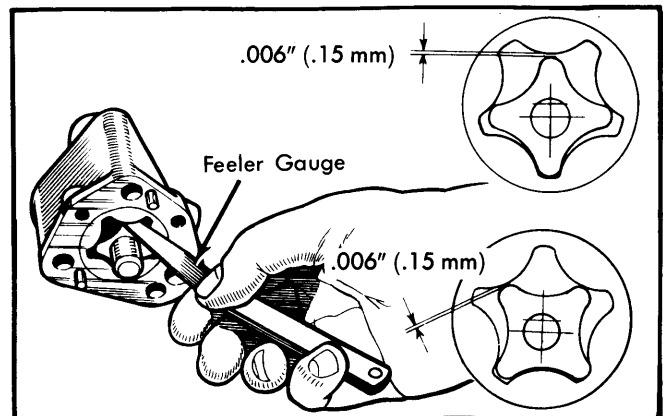

Fig. 9 Measuring Oil Pump Rotor Lobe Clearance

5) Reassemble pump and lubricate all parts with clean engine oil. Make sure outer rotor is installed in pump body with chamfered end at drive end of rotor pocket in pump body.

ENGINE COOLING

Cooling System Capacity — 7.2 quarts with heater.

Thermostat — 180°F (82°C) thermostat is standard. A 190 F (88°C) thermostat is available for use in cold climates.

Pressure Cap — Maintains pressure at 15 psi (1.05 kg/cm³).

WATER PUMP

Removal — Drain cooling system. Remove AIR pump and alternator drive belts, then pivot units out-of-way. Remove water pump bottom hose. Remove belt pulleys. Remove mounting bolts. Withdraw AIR brackets and water pump.

Installation — To install, reverse removal procedure and adjust both belts.

MGB 4 CYLINDER (Cont.)

ENGINE SPECIFICATIONS

GENERAL SPECIFICATIONS										
Year	Displ.		Carburetor	HP at RPM	Torque (Ft. Lbs. at RPM)	Compr. Ratio	Bore		Stroke	
	cu. ins.	cc					in.	mm	in.	mm
1979	110	1798	1x1-Bbl.	8.0-1	3.16	80.26	3.5	88.9

VALVES							
Engine & Valve	Head Diam. In. (mm)	Face Angle	Seat Angle	Seat Width In. (mm)	Stem Diameter In. (mm)	Stem Clearance In. (mm)	Valve Lift In. (mm)
1798 cc Int.	1.562-1.567 (39.67-39.80)	45°	45.5°3429-.3434 (8.70-8.72)	.0007-.0019 (.02-.05)	.3645 (9.25)
Exh.	1.343-1.348 (34.11-34.23)	45°	45.5°3423-.3428 (8.69-8.70)	.0013-.0025 (.03-.06)	.3645 (9.25)

PISTONS, PINS, RINGS						
Engine	PISTONS		PINS		RINGS	
	Clearance In. (mm)	Piston Fit In. (mm)	Rod Fit In. (mm)	Rings	End Gap In. (mm)	Side Clearance In. (mm)
1798 cc	① .0021-.0033 (.053-.084) ② .0006-.0012 (.015-.030)	③	Press Fit	No. 1 No. 2 Oil	.012-.022 (.30-.56) .012-.022 (.30-.56) .015-.045 (.38-1.14)	.0015-.0035 (.038-.088) .0015-.0035 (.038-.088) .0016-.0036 (.04-.09)

- ① - Top.
 ② - Bottom.
 ③ - Hand Push Fit at 60°F (15.6°C).

CRANKSHAFT MAIN & CONNECTING ROD BEARINGS							
Engine	MAIN BEARINGS				CONNECTING ROD BEARINGS		
	Journal Diam. In. (mm)	Clearance In. (mm)	Thrust Bearing	Crankshaft End Play In. (mm)	Journal Diam. In. (mm)	Clearance In. (mm)	Side Play In. (mm)
1798 cc	2.1262-2.1270 (54.01-54.02)	.001-.0027 (.03-.07)	Center	.004-.005 (.10-.13)	1.8759-1.8764 (47.64-47.66)	.001-.0027 (.03-.07)

CAMSHAFT			
Engine	Journal Diam. In. (mm)	Clearance In. (mm)	Lobe Lift In. (mm)
1798 cc Front	1.7888-1.7893 (45.42-45.44)	.001-.002 (.025-.051)	.250 (6.35)
Center	1.7288-1.7293 (43.91-43.92)		
Rear	1.6228-1.6233 (41.22-41.23)		

MG Engines

MGB 4 CYLINDER (Cont.)

ENGINE SPECIFICATIONS (Cont.)

VALVE SPRINGS			
Engine	Free Length In. (mm)	PRESSURE Lbs. @ In. (kg @ mm)	
		Valve Closed	Valve Open
1798 cc	1.92 (48.8)

VALVE TIMING				
Engine	INTAKE		EXHAUST	
	Open (BTDC)	Close (ABDC)	Open (BBDC)	Close (ATDC)
1798 cc	8°	42°	54°	18°

TIGHTENING SPECIFICATIONS	
Application	Ft. Lbs. (mkg)
Main Bearing Nuts	70 (9.7)
Flywheel Set Screws	40 (5.5)
Connecting Rod Bolts	31-35 (4.2)
Rocker Bracket Nuts	25 (3.5)
Oil Pump-to-Crankcase	14 (.8)
Oil Pan Bolts	6 (.8)
Side Covers	3-4 (.4-.5)
Timing Cover	
1/4" Screws	6 (.8)
5/16" Screws	14 (1.9)
Rear Plate	
5/16" Screws	20 (2.8)
3/8" Screws	30 (4.1)
Water Pump	17 (2.3)
Thermostat Housing	8 (1.1)
Rocker Cover Nuts	4 (.56)
Manifold Nuts	16 (2.2)
Clutch-to-Flywheel	25-30 (3.5-4.1)
Carburetor Stud Nuts	15 (2.1)
Cylinder Head	45-50 (6.2-6.9)