

CIVIC 4 CYLINDER

ENGINE CODING

ENGINE IDENTIFICATION

Engine serial number is stamped on a machined surface at rear of engine, near starter. Engine serial number is preceded by engine model number. Model number is EB3.

ENGINE & CYLINDER HEAD

ENGINE

Removal – 1) Disconnect battery ground cable. Remove hood after scribing location marks for reinstallation. Drain radiator and disconnect hoses from engine. Drain lubricant from transmission. Remove air cleaner and air intake pipe.

2) Remove fan shroud. Disconnect hoses from canister fitting being careful not to bend fittings. Disconnect fuel pump inlet line. Disconnect and place out of way the following wires, hoses or cables: Throttle and choke cable from carburetor. Clutch cable from release arm. Ignition coil wires at distributor. Back-up light wires. TCS wires. Alternator harness wires. Water temperature and oil pressure switch wires. Throttle opener hose and carburetor insulator to throttle opener vacuum hose.

3) Remove by-pass valve assembly and bracket. Disconnect heater hoses at firewall. Remove engine torque rod, starter and front wheels. Remove exhaust pipe flange nuts, then lower pipe. Disconnect both lower control arm ball joints.

4) Hold brake disc and pull left and right axle drive shafts out of differential case. Drive out gear shift 8 mm pin and disconnect rod at transmission case. Disconnect gearshift extension at engine (not at shift lever). On automatic transmission models only, disconnect shift cable at console, then disconnect cooler lines at transmission.

5) Attach an engine hoist to motor and take up slack allowing load to be lifted from mounts. With engine supported, remove two center mount bracket nuts. Remove left engine mount. Lift engine from vehicle being careful not to allow auxiliary components to bang against vehicle.

Installation – To install engine, reverse removal procedure and note the following: Use new shift rod pin. After installing drive shafts attempt to move inner joint housing in and out of differential housing. If movement is easy, drive shaft end clips should be replaced. When connecting heater hoses, upper hose goes to water pump connecting pipe.

CYLINDER HEAD

NOTE – To minimize the chances of warping cylinder head, remove head after engine has been allowed to cool.

Removal – 1) Scribe index marks on hood, then take hood off. Drain coolant from radiator. Remove air cleaner hardware. Disconnect upper radiator hose. Disconnect tubing between canister and idle cut-off valve. Disconnect throttle linkage.

2) Disconnect the following items: heater hoses at intake manifold. Temperature sensor wires. Fuel line to carburetor. Engine torque rod.

3) Remove air pump to exhaust manifold hose. Disconnect exhaust pipe at manifold. Remove valve cover. Remove upper timing belt cover. Bring No. 1 piston to TDC.

4) Loosen timing belt adjusting and pivot bolt, then remove camshaft pulley bolt and remove pulley. Take off fuel pump and take out distributor. Remove the oil pump gear holder and the pump gear and shaft. Loosen bolts evenly and lift off cylinder head.

Installation – To install cylinder head, reverse removal procedure and tighten bolts in sequence shown in Fig. 1.

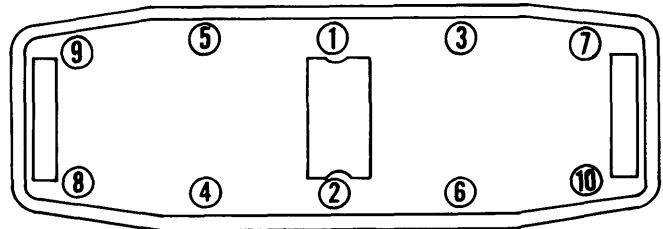

Fig. 1 Cylinder Head Tightening Sequence (Loosen in Reverse Sequence)

CAMSHAFT

TIMING BELT

1) Remove water pump drive belt, water pump pulley and crankshaft pulley. Remove upper timing belt cover from cylinder head.

2) Remove lower timing belt cover from engine block. Loosen (do not remove) timing belt adjusting and pivot bolts. Slide belt off pulleys. To install, reverse removal procedure using care not to excessively bend or twist timing belt. Do not expose belt to engine oil as this will cause belt rubber to swell. Install belt in same direction of rotation to prevent premature wear or failure.

CAMSHAFT

1) With cylinder head removed, loosen rocker shaft support bolts in a criss-cross pattern beginning with outside support. Lift rocker shaft assembly from head. Remove camshaft and right head seal or tachometer drive body (if equipped).

2) Inspect camshaft and cylinder head bearing surfaces for wear or damage. Check camshaft maximum runout of .002" (.05 mm). Measure cam lobes for no more than .0118" (0.3 mm) wear from standard dimension of 1.4477-1.4363" (36.77-36.48 mm) for intake lobes and 1.4429-1.4311" (36.65-36.35 mm) for exhaust lobes. End play of camshaft when installed in head should not exceed .0197" (.50 mm). Standard oil clearance between camshaft and head is from .0020-.0035" (.05-.09 mm).

3) Oil camshaft bearing journals. Install camshaft and seal or tachometer drive body (if equipped). Loosen rocker arm adjusting screws, and apply silicone seal to mating surfaces on end camshaft supports and cylinder head. Install rocker arm assembly and tighten support bolts in reverse of removal.

VALVE TIMING

Rotate crankshaft pulley until TDC mark is aligned with index mark on timing belt cover. Rotate camshaft pulley until

CIVIC 4 CYLINDER (Cont.)

Woodruff key is facing up and timing marks on pulley are parallel with top of cylinder head. Without disturbing pulley position, slide on timing belt. Rotate engine a quarter of a turn in the normal direction (counterclockwise when viewed from timing belt end) and tighten adjusting bolt, then pivot bolt. Do not apply pressure to timing belt; use only tension of adjusting spring.

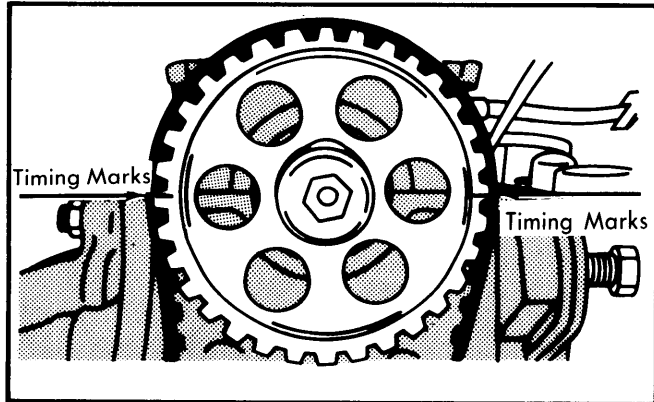

Fig. 2 Camshaft Alignment Marks in Position for Installing Camshaft Belt

VALVES

VALVE ARRANGEMENT

Front Side — All Exhaust
Rear Side — All Intake

ROCKER ARM ASSEMBLY

Removal — Loosen rocker arm shaft bolts in criss-cross pattern starting with end supports. Starting with number four cylinder support, pull out 4 mm pin and remove supports, rocker collars, rocker arms and springs. Retain components in proper order for reassembly.

Installation — When reinstalling rocker arms, place intake rocker arm shaft so that notch faces rear of vehicle and oil holes are on the bottom. Exhaust rocker arm shaft is installed with oil holes facing down and dowel pin hole on left-hand side of engine. After assembly check rocker arms for freedom of movement.

VALVE SPRINGS

Using a suitable valve spring compressor, remove valve keepers, collars and springs. Check valve springs for squareness, they should be within 2° of true. Measure free length of spring. Minimum length for inner and outer intake springs is 1.6063" (40.8 mm). Inner exhaust valve spring should be at least 1.9291" (49.0 mm), and outer spring should be at least 2.0591" (52.3 mm).

VALVE GUIDE SERVICING

Using a suitable drift, drive valve guides out top side of head. Install new guides and ream to provide proper clearance. Install new intake valve guide seals.

VALVE CLEARANCE ADJUSTMENT

1) Rotate engine until number 1 piston is at TDC on compression stroke. Check intake valves of number 1 and 2 cylinders

and exhaust valves of number 1 and 3 cylinders. Rotate crankshaft 360° and check intake valves of number 3 and 4 cylinders and exhaust valves of number 2 and 4 cylinders.

2) Loosen lock nut of valve to be adjusted. Insert a feeler gauge between rocker arm and valve stem to measure clearance. Turn adjuster until proper clearance is obtained. This procedure is performed with engine cold, and proper valve clearance is .004-.006" (.10-.16 mm).

PISTONS, PINS & RINGS

OIL PAN

1) Raise front of vehicle and support with floor stands. Attach a hoist to clutch cable bracket on transmission and raise just enough to take load off center mount.

2) Remove center beam and lower engine mount. Loosen and remove oil pan bolts in a criss-cross pattern, starting from outside bolts. Tap corners lightly with a mallet to break seal and remove oil pan.

PISTON & ROD ASSEMBLY

1) With oil pan and cylinder head removed, ream any ridge from top of cylinders. Mark piston and rod assemblies for proper reinstallation. Remove rod caps and push piston and rod assemblies out top of cylinder with a hammer handle.

2) Assemble piston and connecting rod with piston front mark and connecting rod oil jet hole on same side and facing intake manifold. Using a ring compressor, install piston and rod assemblies in proper cylinder.

FITTING PISTONS

Measure cylinder bore for wear and taper. Measure piston diameter, then determine if piston-to-cylinder clearance is within specification. If not, two different oversize pistons (and

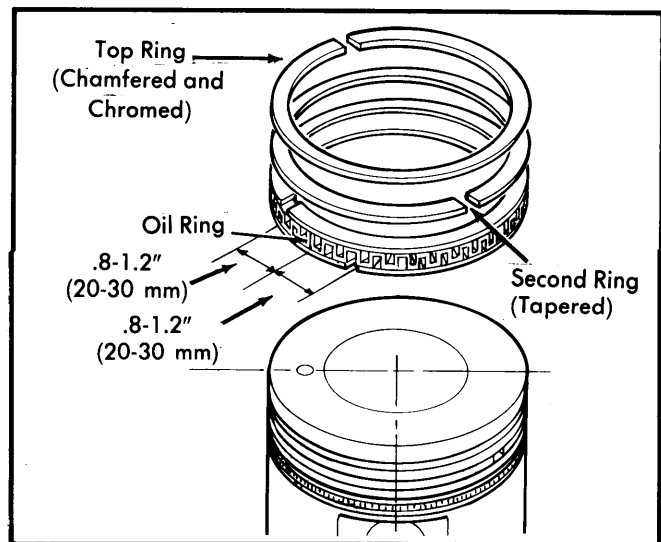

Fig. 3 View of Piston Rings Showing Ring End Gap Locations

rings) are available. Oversizes are .010" (.25 mm) and .020" (.50 mm). Oversize pistons are stamped on the crown with a number corresponding to the metric equivalent of oversize. Similarly, oversize rings are also stamped on their top side to

CIVIC 4 CYLINDER (Cont.)

correspond to amount to oversize. Match pistons and rings according to these oversize markings.

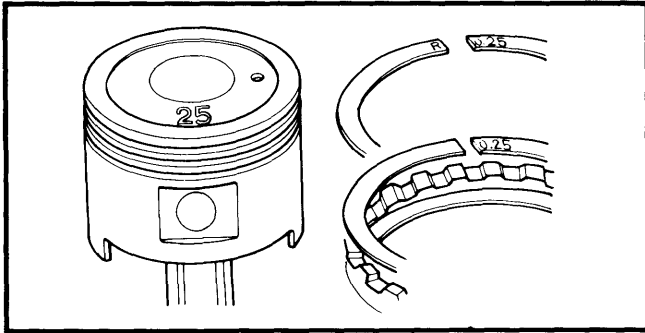

Fig. 4 Piston and Ring Size Markings

PISTON PINS

Using a press and suitable tool (07973-6570001), press piston pin out of piston and connecting rod. Install new pin by placing pilot through piston and connecting rod. Lightly oil piston pin and place piston, rod, pin and ram on the base. Press in pin until it is centered in connecting rod.

CRANKSHAFT MAIN & CONNECTING ROD BEARINGS

MAIN & CONNECTING ROD BEARINGS

1) Loosen main bearing cradle bolts in a criss-cross sequence beginning at ends of cradle. Mark connecting rods, caps and pistons for reassembly in original positions, then remove main bearing cradle and rod caps. Remove and measure crankshaft for bend, out-of-round, or taper.

NOTE — Bearing journals are specially heat-treated and should not be reground. Do not attempt to adjust bearing clearances by filing or shimming bearing caps.

2) Using Plastigage method, determine bearing clearances. If bearing replacement is necessary use following procedure to determine bearing size required.

3) Referring to illustration, note that all letters stamped on crankshaft counterweight pads apply to connecting rods and all numbers apply to main bearing journals. Both connecting rods and main bearing journals have mating numbers (stamped on connecting rod) or letters (stamped on block) which when paired are used to determine color of bearing insert to be used. See Engine Specifications

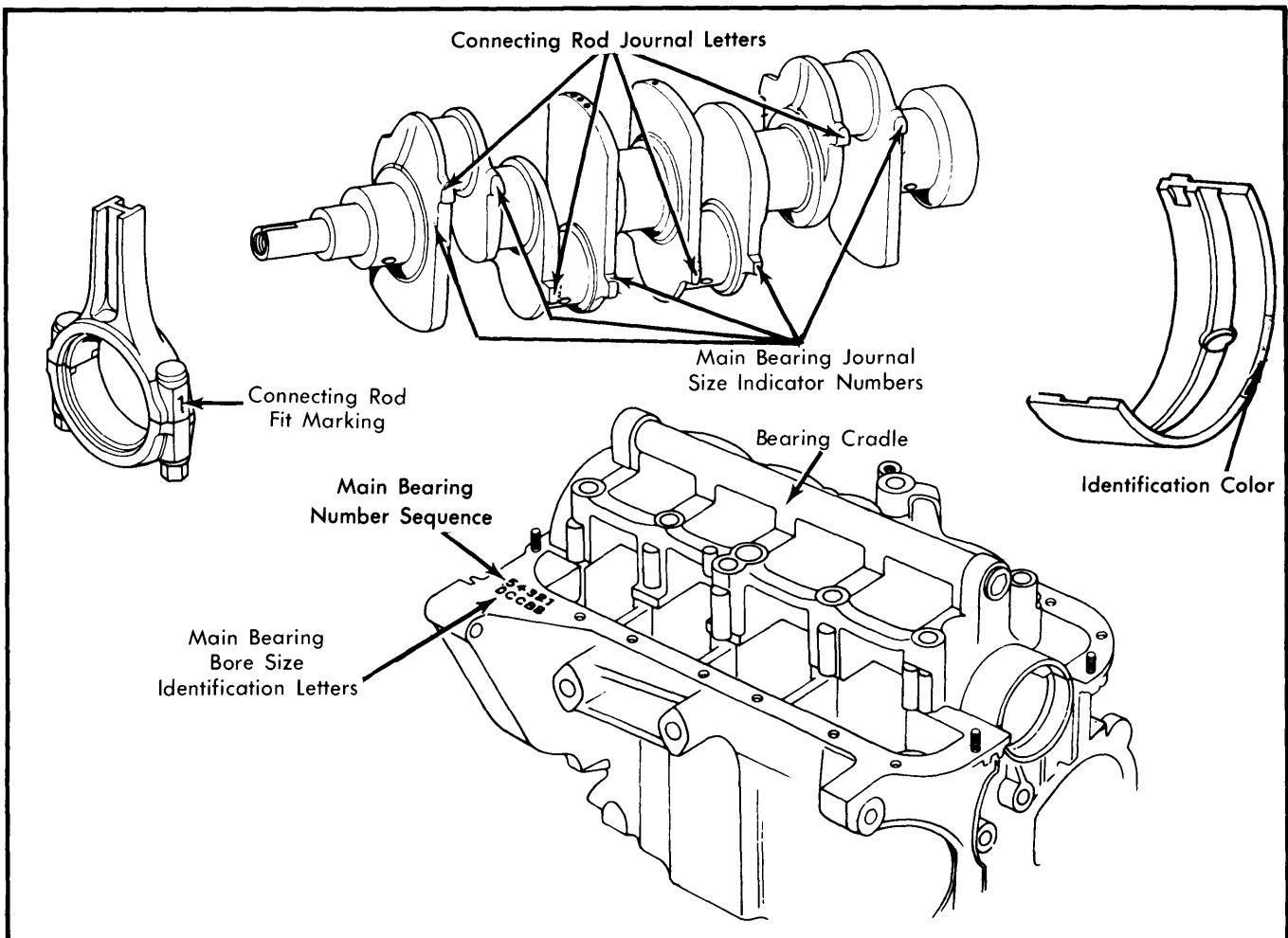

Fig. 5 Crankshaft and Connecting Rod Bearing Identification with Detail for Each Component

CIVIC 4 CYLINDER (Cont.)

THRUST BEARING ALIGNMENT

Measure thrust bearing clearance and replace thrust washers if necessary. Install thrust washers with oil grooves facing toward crankshaft.

ENGINE OILING

Crankcase Capacity - 3.2 qts.
Oil Filter - Disposable with built-in by-pass valve.
Normal Oil Pressure - 48-58 psi, 21 psi minimum at idle.
Pressure Regulator Valve - Non-adjustable.

ENGINE OILING SYSTEM

A trochoid type oil pump draws oil from oil pan and delivers it under pressure through main bearing cradle to main and connecting rod bearings. Oil passes through rods to an oil jet which lubricates pistons and cylinder walls. An oil passage carries oil to camshaft bearings and rocker arms. Oil mist lubricates valve stems.

OIL PUMP

- 1) Remove oil pan, oil passage block and oil pump assembly. Pull oil relief valve cotter pin and remove seat, spring and valve.
- 2) Remove two pump body bolts and disassemble pump. Inspect pump for wear or damage. Measure pump operating clearances. Reassemble pump and place strainer in container of engine oil. Rotate pump with a screwdriver and check that oil comes out of delivery side. Place finger over hole and see if pressure develops as pump is turned.

Oil Pump Specifications		
Application	Std. Clearance In. (mm)	Service Limit In. (mm)
Inner-to-Outer Rotor0059..... (.15).....	.0079 (.20)
Rotor-to-Body0012-.0039..... (.03-.10).....	.0059 (.15)
Rotor Side-to-Body0039-.0071..... (.10-.18).....	.0079 (.20)

ENGINE COOLING

Thermostat - Opens at 178-183°F (80-84°C).
Thermoswitch - On: 191-197°F (88-92°C); Off: 182-188°F (83-87°C).
Cooling System Capacity - 4.2 qts.

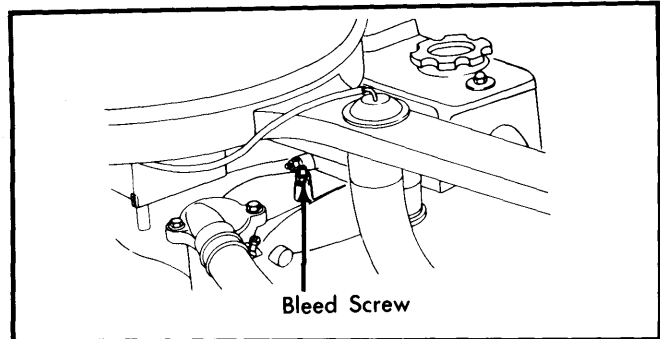

Fig. 6 Coolant Bleed Valve in Intake Manifold

WATER PUMP

Removal - Drain radiator and loosen alternator adjusting bolts. Push alternator toward engine and remove drive belt. Remove pump and "O" ring seal.

Installation - 1) Reinstall water pump. Loosen cooling system bleed valve located on intake manifold, see Fig. 6. Fill radiator with coolant. When air bubbles no longer appear in coolant draining from bleed valve, close valve.

2) Start engine and place heater temperature control lever in high position. Run engine approximately ten minutes. Again bleed system until there are no air bubbles in coolant draining from bleed valve. Refill radiator.

ENGINE SPECIFICATIONS

GENERAL SPECIFICATIONS										
Year	Displ.		Carburetor	HP at RPM	Torque (Ft. Lbs. at RPM)	Compr. Ratio	Bore		Stroke	
	cu. ins.	cc					in.	mm	in.	mm
1979	75.48	1237	2-Bbl.	8.1:1	2.83	72	2.99	76

VALVES							
Engine & Valve	Head Diam. In. (mm)	Face Angle	Seat Angle	Seat Width In. (mm)	Stem Diameter In. (mm)	Stem Clearance In. (mm)	Valve Lift In. (mm)
1237 cc Intake	1.335-1.342 (33.9-34.1)	45°	45°	.0551 (1.4)	.2591-.2594 (6.58-6.59)	.0008-.0020 (.02-.05)
Exhaust	1.177-1.185 (29.9-30.1)	45°	45°	.0551 (1.4)	.2579-.2583 (6.55-6.56)	.0020-.0031 (.05-.08)

CIVIC 4 CYLINDER (Cont.) ENGINE SPECIFICATIONS (Cont.)

VALVE TIMING				
Engine	INTAKE		EXHAUST	
	Open (ATDC)	Close (ALDC)	Open (BLDC)	Close (BTDC)
1237 cc	10°	20°	30°	10°

PISTONS, PINS, RINGS						
Engine	PISTONS	PINS		RINGS		
	Clearance In. (mm)	Piston Fit In. (mm)	Rod Fit In. (mm)	Rings	End Gap In. (mm)	Side Clearance In. (mm)
1237 cc	0-.0016 (0-.04)	.0003-.0007 (.007-.014)	⓪ .0006-.0015 (.016-.039)	No. 1	.008-.016 (.20-.40)	.0008-.0018 (.020-.045)
				No. 2	.008-.016 (.20-.40)	.0008-.0018 (.020-.045)
				Oil	.011-.039 (.3-.9)

⓪ — Interference fit.

Main Bearing Journals					In. (mm)
Crankcase Counterbore Dia. 2.13 (54) Journal Dia. 1.97 (50)	A	B	C	D	
		0 to .0002 (0 to .006)	.0002 to .0005 (.006 to .012)	.0005 to .0007 (.012 to .018)	.0007 to .0009 (.018 to .024)
1 0 to -.0002 (0 to -.006)	Red -.0001 to -.0002 (-.002 to -.005)	Pink .00004 to -.0001 (.001 to -.002)	Yellow .0002 to .00004 (.004 to .001)	Green .0003 to .0002 (.007 to .004)	
2 -.0002 to -.0005 (-.006 to -.012)	Pink .00004 to -.0001 (.001 to -.002)	Yellow .0002 to .00004 (.004 to .001)	Green .0003 to .0002 (.007 to .004)	Brown .0004 to .0003 (.010 to .007)	
3 -.0005 to -.0007 (-.012 to -.018)	Yellow .0002 to .00004 (.004 to .001)	Green .0003 to .0002 (.007 to .004)	Brown .0004 to .0003 (.010 to .007)	Black .0005 to .0004 (.013 to .010)	
4 -.0007 to -.0009 (-.018 to -.024)	Green .0003 to .0002 (.007 to .004)	Brown .0004 to .0003 (.010 to .007)	Black .0005 to .0004 (.013 to .010)	Blue .0006 to .0005 (.016 to .013)	

CRANKSHAFT MAIN & CONNECTING ROD BEARINGS							
Engine	MAIN BEARINGS				CONNECTING ROD BEARINGS		
	Journal Diam. In. (mm)	Clearance In. (mm)	Thrust Bearing	Crankshaft End Play In. (mm)	Journal Diam. In. (mm)	Clearance In. (mm)	Side Play In. (mm)
1237 cc	1.969-1.970 (49.9-50.0)	.0009-.0017 (.024-.042)	No. 2	.004-.014 (.10-.35)	1.575-1.576 (39.9-40.0)	.0008-.0015 (.020-.038)	.0059-.0118 (.15-.30)

Honda Engines

CIVIC 4 CYLINDER (Cont.) ENGINE SPECIFICATIONS (Cont.)

Connecting Rod Bearing Journals				In. (mm)
Connecting Rod Dia. 1.69 (43) Crankpin Dia. 1.57 (40)	1 0 to .0002 (0 to .006)	2 .0002 to .0005 (.006 to .012)	3 .0005 to .0007 (.012 to .018)	4 .0007 to .0009 (.018 to .024)
	A 0 to -.0002 (0 to -.006)	Red -.0002 to -.0003 (-.005 to -.008)	Pink -.0001 to -.0002 (-.002 to -.005)	Yellow .00004 to -.0001 (.001 to -.002)
B -.0002 to -.0005 (-.006 to -.012)	Pink -.0001 to -.0002 (-.002 to -.005)	Yellow .00004 to -.0001 (.001 to -.002)	Green .0002 to .00004 (.004 to .001)	Brown .0003 to .0002 (.007 to .004)
C -.0005 to -.0007 (-.012 to -.018)	Yellow .00004 to -.0001 (.001 to -.002)	Green .0002 to .00004 (.004 to .001)	Brown .0003 to .0002 (.007 to .004)	Black .0004 to .0003 (.010 to .007)
D -.0007 to -.0009 (-.018 to -.024)	Green .0002 to .00004 (.004 to .001)	Brown .0003 to .0002 (.007 to .004)	Black .0004 to .0003 (.010 to .007)	Blue .0005 to .0004 (.013 to .010)

TIGHTENING SPECIFICATIONS

Application	Ft. Lbs. (mkg)
Main Bearing Cap	27-31 (3.7-4.3)
Connecting Rod Cap	18-21 (2.6-3.0)
Camshaft Support	13-16 (1.8-2.4)
Flywheel	34-38 (4.7-5.3)
Cylinder Head Bolts	37-42 (5.1-5.8)
Crankshaft Pulley	34-38 (4.7-5.3)
Timing Belt Pulley	18-25 (2.5-3.5)
Intake & Exhaust Manifolds	13-17 (2.0-2.5)