

## 1400, 1600, 2000 & 2600 cc 4 CYLINDER

### ENGINE CODING

#### ENGINE IDENTIFICATION

Engine model code and serial number is stamped on engine block just below number 1 spark plug on right side of block. Model codes are as follows:

Application In. (cc)	Engine Model	Model Code
86.0 (1400)	J	G21B
97.5 (1600)	K	G32B
121.7 (2000)	U	G52B
155.9 (2600)	F	G54B

### ENGINE & CYLINDER HEAD

#### ENGINE

**Removal (Rear Wheel Drive Models) – 1)** Drain cooling system, remove battery and remove engine hood. Disconnect ground strap, wiring from ignition coil, vacuum control solenoid valve, fuel cut-off solenoid valve, generator, starter, transmission switch, back-up light switch, water temperature gauge and oil pressure switch.

**2)** Remove air cleaner and disconnect attaching hoses. Disconnect accelerator linkage and heater hoses. Unbolt and separate exhaust pipe from manifold. Disconnect pipe mounting bracket at transmission.

**3)** Disconnect hose between fuel filter and fuel pump return pipe. Remove radiator and radiator shroud. If equipped with automatic transmission, remove oil cooler pipe and tie rod when removing radiator.

**4)** Remove console box, then detach control lever assembly from transmission. Remove hood. Disconnect speedometer cable and back-up light switch wiring from transmission. Disconnect clutch cable from shift lever and then disconnect cable from its bracket (if equipped with manual transmission). Drain transmission. If equipped with transmission dynamic vibration damper, remove damper, remove locking bolts for attaching flange yoke at rear of propeller shaft, then draw shaft out of transmission.

**5)** Support transmission on a suitable jack and remove front and rear mount bolts. Remove rear engine support bracket. Attach suitable lifting device to front and rear engine hangers. Lift engine-transmission assembly at an angle, upward and out of engine compartment.

**NOTE** – Keep transmission lower than engine when removing. If lower part of bell housing interferes with relay rod, raise rear of transmission to clear rod, then remove engine-transmission assembly.

**Removal (Front Wheel Drive Models) – 1)** Drain cooling system and remove battery and tray. Remove air cleaner assembly. Remove purge control valve bracket from battery support and disconnect vacuum hose from valve. Remove windshield washer tank and coolant reservoir.

**2)** Remove radiator assembly and cooling fan. Disconnect the following from engine-transaxle: clutch, accelerator and speedometer cables; heater hose, fuel hoses, VCU vacuum hose, idle up switch vacuum hose; wires from starter, engine ground, alternator, coolant temperature, ignition coil, high-temp sensor, back-up light and oil pressure switch.

**3)** Remove ignition coil. From under vehicle, remove under-cover and drain transaxle. Remove right and left drive shafts from transaxle case and suspend with wire to prevent damaging joints. Cover holes in transaxle case to prevent entry of foreign matter.

**NOTE** – Drive shaft retainer rings should be replaced whenever drive shafts are removed from transaxle.

**4)** Remove assist rod, control rod and range selector cable from transaxle. Disconnect and suspend exhaust pipe. Remove front roll rod bolts and loosen transaxle mounting bracket attaching nuts. Remove bolts and nuts from front and rear engine insulators and disconnect rear roll rod.

**5)** Suspend engine from chains attached to hoisting brackets and remove mounting bracket nuts loosened previously. Lift engine-transaxle assembly from vehicle using care that assembly does not hit battery bracket during removal.

**Installation (All Models) –** Reverse removal procedures and tighten mounting bolts and nuts to specifications with weight of engine on insulators. Replace all fluids and adjust all cables and linkages.

#### CYLINDER HEAD & INTAKE MANIFOLD

**Removal – 1)** Drain cooling system. Disconnect water hoses at cylinder head, manifold and carburetor. Remove breather and purge hose, vacuum hose at distributor and purge control valve.

**2)** Disconnect accelerator linkage, spark plug wires, water temperature gauge unit and exhaust manifold flange. Remove air cleaner, fuel line, distributor and fuel pump. Remove exhaust manifold, then intake manifold and carburetor assembly.

**3)** Remove rocker cover and breather. On 1400 and 1600 cc engine, remove timing belt upper front cover. Turn crankshaft so number 1 piston is at TDC on compression stroke. Mark belt (1400 or 1600 cc) or chain (2000 and 2600 cc) with suitable marker in line with sprocket mark. On 1400 cc engine, move timing belt tensioner fully toward water pump and slide belt off camshaft sprocket.

**4)** Except on 1400 cc engine, remove camshaft sprocket from camshaft. On 1600 cc engine, remove timing belt upper inner cover. Remove cylinder head bolts in 2 or 3 stages according to sequence shown in Fig. 2, loosening high numbers first. Lift off head using caution to avoid twisting sprocket and chain (or belt).

# Chrysler Corp. Import Engines

## 1400, 1600, 2000 & 2600 cc 4 CYLINDER (Cont.)

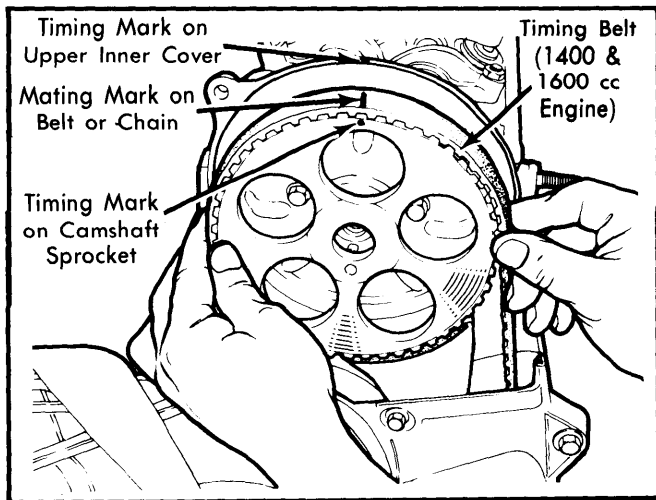

**Fig. 1** Aligning Timing Marks at TDC (1400 & 1600 cc Engine Shown)

**Installation** - 1) To install, reverse removal procedure. Gasket surfaces must be clean and NEW gaskets must be used. Use sealer ONLY at points where cylinder head joins front cover case (2000 and 2600 cc engines) and to intake manifold gasket around water passages (all models). On 1400 cc engine, ensure that timing belt tensioner is properly adjusted.

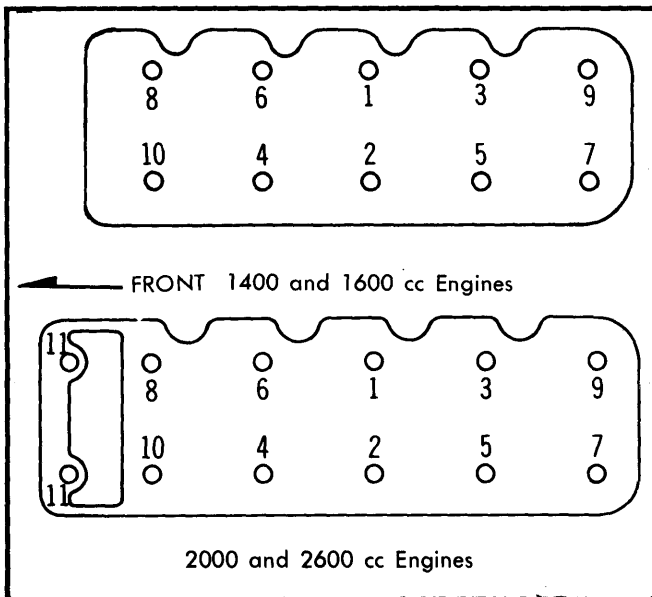

**Fig. 2** Cylinder Head Bolt Tightening Sequence (Remove in Reverse Order)

**NOTE** - Avoid sliding cylinder head when installing in order to prevent damage to gasket and aligning dowels (when installed). Engine should not be run with rocker cover off due to oil spray from rocker arms.

2) Tighten cylinder head bolts to initial torque (25 ft. lbs. for 1600 cc, 35 ft. lbs. for others) according to sequence shown in Fig. 2. Repeat the procedure, retightening all cylinder head bolts to specified torque.

3) Temporarily set valve clearance to cold engine settings, then readjust to hot engine settings after engine is at normal operating temperature. Install rocker cover, air cleaner and breather hoses.

### CAMSHAFT

#### ROCKER ARMS & SHAFTS (1400 cc)

**Removal & Installation** - Remove air cleaner, breather hose to rocker cover and rocker cover. Remove rocker shaft mounting bolts and lift off rocker shaft, rocker arms and rocker arm springs as an assembly. Remove bolts from shafts and slide off springs and rocker arms. To install, ensure that short springs are used on right hand rocker arm and reverse removal procedure.

#### CAMSHAFT (1400 cc)

**Removal** - 1) Remove rocker arms and shafts as previously described. Remove timing belt cover and move belt tensioner fully toward water pump, ensuring that camshaft sprocket mark is aligned with head timing mark. Remove timing belt and camshaft sprocket from camshaft.

2) Remove distributor and fuel pump. Remove camshaft rear cover from rear of head and thrust case tightening bolt from top of head. Tap sprocket end of shaft with brass drift and remove camshaft from rear of head.

3) Check thrust case for camshaft end play. If excessive, replace thrust case and recheck. If rear of camshaft journal is badly worn, replace camshaft. To install, thoroughly lubricate camshaft and seal lips and reverse removal procedure.

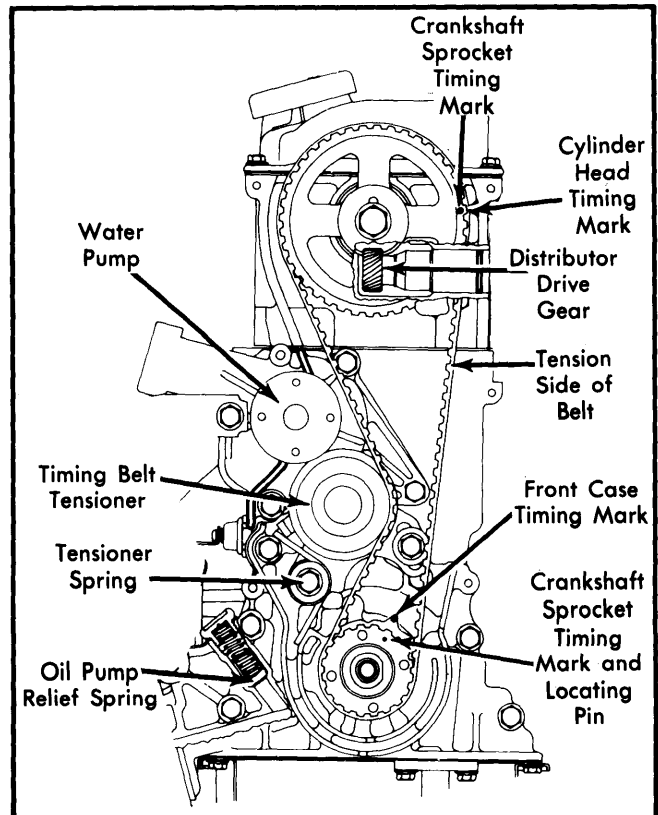

**Fig. 3** View of 1400 cc Timing Belt Installation

## 1400, 1600, 2000 & 2600 cc 4 CYLINDER (Cont.)

### COUNTERBALANCE SHAFTS & TIMING BELT (1600 cc)

**NOTE** — Timing belt drives camshaft, oil pump and left counterbalance shaft. A separate belt drives counterbalance shaft on right side.

**Removal** — 1) With engine removed and timing belt marked. Remove crankshaft pulley, upper and lower timing belt front covers. Loosen belt tensioner mounting nut and bolt. Remove timing belt. Remove camshaft sprocket, crankshaft sprocket and flange, remove timing belt tensioner.

2) Remove plug at bottom of left side of cylinder block and insert a screwdriver, to keep left counterbalance shaft in position. Remove crankshaft sprocket and counterbalance shaft sprocket from right side. Remove timing belt covers from right side. Remove water pump and cylinder head assembly. Remove oil pan and oil pick-up screen. Remove oil pump cover.

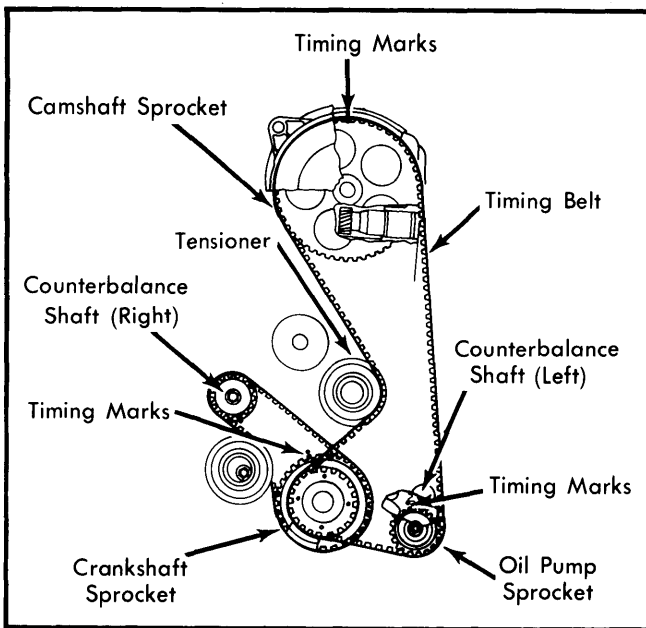

**Fig. 4 Counterbalance and Timing Belt Installation (1600 cc)**

3) With screwdriver through plug hole in cylinder block to hold counterbalance shaft, loosen oil pump driven gear bolt. Remove front case with left counterbalance shaft attached. Remove right counterbalance shaft from cylinder block.

**Installation** — 1) To install, reverse removal procedure. Check to ensure that all timing marks are in alignment. To adjust tension on right side. Lift tensioner toward belt; tighten nut and bolt. Make sure that the shaft of the tensioner does not rotate in the same direction as the bolt tightens. Correct adjustment is obtained when belt deflects .20-.27" (5-7 mm) with finger pressure.

2) To adjust counterbalance shaft and timing belt, start with timing belt installed on crankshaft sprocket, oil pump sprocket and camshaft sprocket, making sure that all timing marks are in alignment. With tensioner installed, lightly push up toward mounting nut, to make sure that timing belt comes into complete mesh with camshaft sprocket. Tighten mounting nut and bolt (tighten nut first).

3) Turn crankshaft through a complete rotation in normal direction. (Make sure that crankshaft is turned smoothly and in the correct direction.) Loosen tensioner mounting nut and bolt. At this time, the loose side of the belt will be given tension. Tighten nut and bolt (nut first).

### COUNTERBALANCE DRIVE CHAIN (2000 & 2600 cc)

**Removal** — Remove crankshaft pulley and timing chain case. Remove chain guides A, B and C, sprocket B locking bolts and crankshaft sprocket (B). Remove both countershaft sprockets (B) and drive chain. See Figs. 5 and 6.

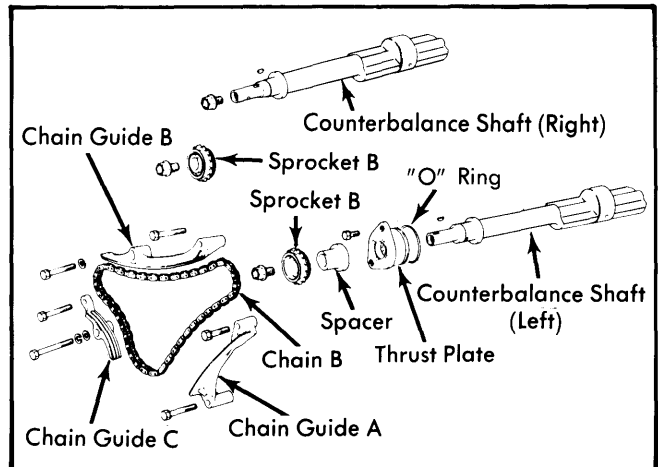

**Fig. 5 Exploded View of Counterbalance Shafts and Drive Chain (2000 and 2600 cc)**

**Installation** — Refer to Figs. 5 and 6 for component location and reverse removal procedure. Ensure that mating marks on sprockets align with plated links on counterbalance chain. Adjust tension by installing guides A and C, then shake counterbalance shaft sprockets to take slack from chain. Adjust guide B so that there will be .040-.140" (1.0-3.5 mm) clearance between guide and chain at point P. Tighten guide mounting bolts and complete assembly.

### COUNTERBALANCE SHAFTS (2000 & 2600 cc)

**Removal & Installation** — 1) With counterbalance drive chain removed, remove oil pump mounting bolts. Remove bolt holding oil pump driven gear and counterbalance shaft together, then remove oil pump mounting bolts. Remove oil pump, then withdraw counterbalance shaft.

## 1400, 1600, 2000 & 2600 cc 4 CYLINDER (Cont.)

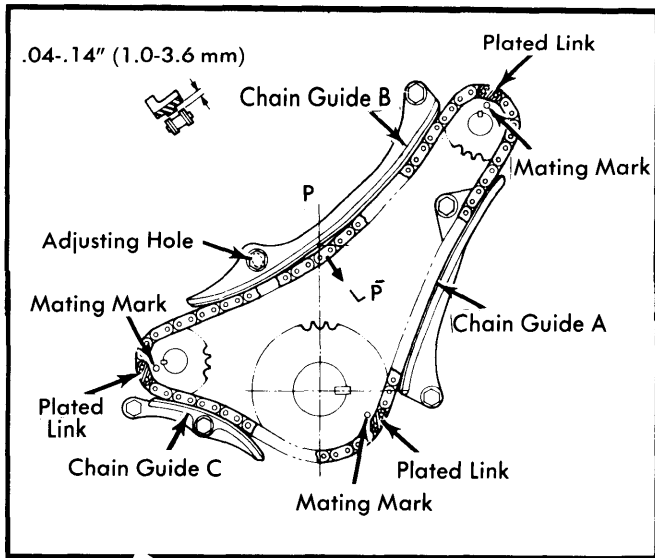

**Counterbalance Drive Chain  
(2000 and 2600 cc)**

**NOTE** — If bolt locking oil pump driven gear and counterbalance shaft is hard to loosen, remove oil pump and counterbalance shaft as an assembly. Then remove lock bolt to disassemble.

2) Remove thrust plate supporting front of left counterbalance shaft. (Thrust plate is removed by threading bolts into plate holes at same time). Withdraw counterbalance shaft from cylinder block. To install, reverse removal procedure.

### TIMING CHAIN (2000 & 2600 cc)

**Removal & Installation** — With counterbalance drive chain removed, take off chain tensioner and right and left chain guides. Remove camshaft sprocket and timing chain. To install, rotate crankshaft until number 1 piston is at TDC on compression stroke, align mating marks on sprockets and chain, then install chain on camshaft and crankshaft with keys and keyways aligned. Inspect chain tensioner and complete installation in reverse order of removal.

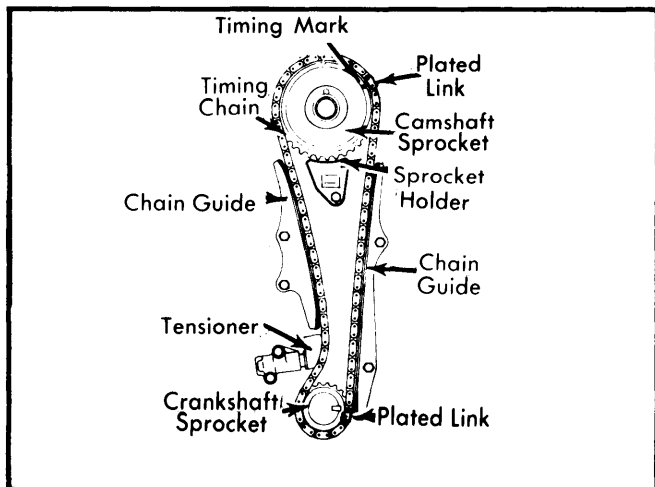
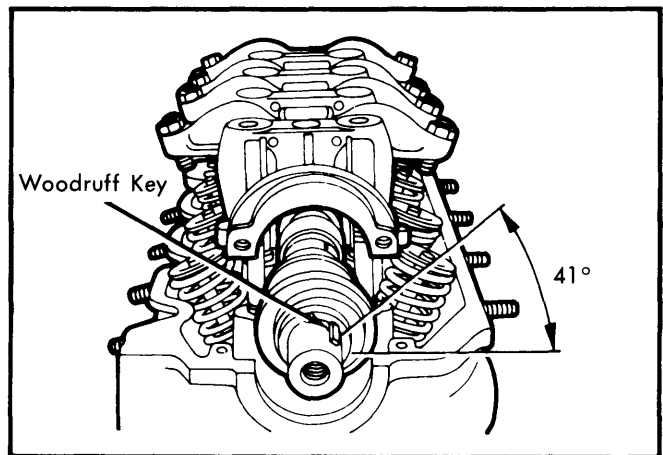

**Fig. 7 Camshaft Sprocket Alignment and Installation  
(2000 & 2600 cc)**

### CAMSHAFT (1600, 2000 & 2600 cc)

**Removal** — Remove camshaft bearing cap nuts. Remove rocker arms, shafts and bearing caps as an assembly. Disassemble rocker arms and shafts, if required, keeping all components in order so they will be reinstalled in original positions. Remove camshaft from cylinder head.

**Installation** — 1) Install camshaft on head with keyway at 41° position (1600 cc engines) or dowel in 12 o'clock position (2000 and 2600 cc engines). See Figs. 8 and 9. Assemble rocker arm assembly, assuring that mating marks on bearing caps and rocker arm shafts face front of engine and are properly aligned with one another. Insert bolts through bearing caps and rocker arm shafts to keep assembly together during installation.



**Fig. 8 Camshaft Woodruff Key Position for Installation  
(1600 cc Engine)**

2) Install rocker arm assembly to cylinder head, assuring that camshaft is in proper position. Tighten bolts to 7 ft. lbs. (1 mkg) in sequence of center, 2, 4, front and rear. Repeat sequence, tightening to specified final torque.

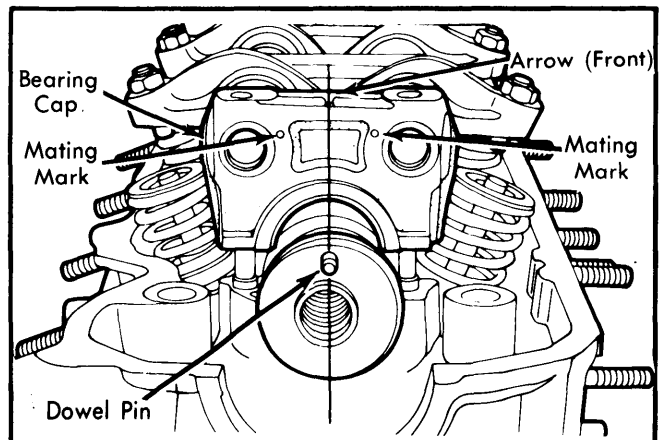

**Fig. 9 Camshaft Installation Position and Bearing Cap/Rocker Arm Shaft Mating Marks  
(2000 and 2600 cc Engines)**

## 1400, 1600, 2000 & 2600 cc 4 CYLINDER (Cont.)

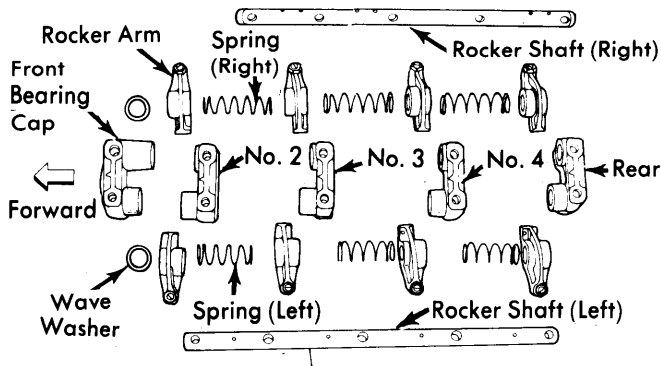

**Fig. 10 Exploded View of Rocker Arm and Shaft Assembly (2000 cc Shown; 1600cc and 2600 cc Similar)**

### VALVES

#### VALVE ARRANGEMENT

Intake — Left side.  
 Exhaust — Right side.  
 Jet Valve — Left side.

#### JET VALVES

Using special Jet Valve Socket Wrench (MD998310), remove jet valves. Disassemble valve using spring pliers (MD998309) to compress spring and remove retainer lock. Check valve head and seat for damage and make sure jet valve slides smooth in body without play.

**CAUTION** — Make certain that jet valve socket wrench is not tilted with respect to center of valve when used. If tool is tilted, stem may be bent resulting in defective valve operation and a broken wrench. Do not disturb jet valve and body combination. If defective, jet valve and body should be replaced as an assembly.

#### VALVE SPRINGS

With camshaft and rocker arm assembly removed, use valve lifter and remove retainer locks (keepers). Remove all retainers, springs, spring seats and valves, keeping in proper order for reassembly. Check valve spring free length and pressure. Standard spring squareness should be 1.5° or less. If beyond 3°, replace spring.

#### VALVE GUIDE SERVICING

1) Check valve stem-to-guide clearance, and if clearance exceeds service limits as listed in table, replace valve guide with next oversize component. Guides are available in the following oversizes:

##### Valve Guide Oversizes

Size Mark	Guide Size In. (mm)	Cyl. Head Bore In. (mm)
5.....	.002 (.05).....	.5138-.5145 (13.05-13.07)
25.....	.010 (.25).....	.5216-.5224 (13.25-13.27)
50.....	.020 (.50).....	.5315-.5323 (13.50-13.52)

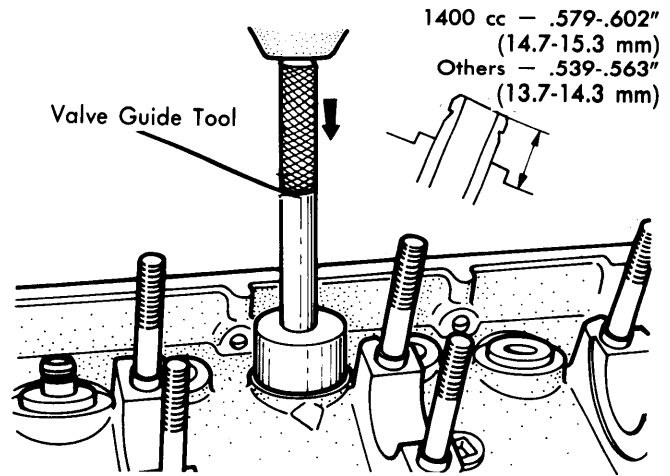

**Fig. 11 Valve Guide Installation and Height**

2) Heat cylinder head to approximately 480°F (249°C), and then use a suitable valve guide tool to drive out each guide toward the combustion chamber. Ream guide bore in cylinder head to specified size (after head has cooled to room temperature).

3) To install new guides, reheat head to same temperature, quickly insert and drive guides into head. Guide should protrude .579-.602" (14.7-15.3 mm) for 1400 cc or .539-.563" (13.7-14.3 mm) for other engines above head surface when properly installed. Check guide I.D. and ream as necessary.

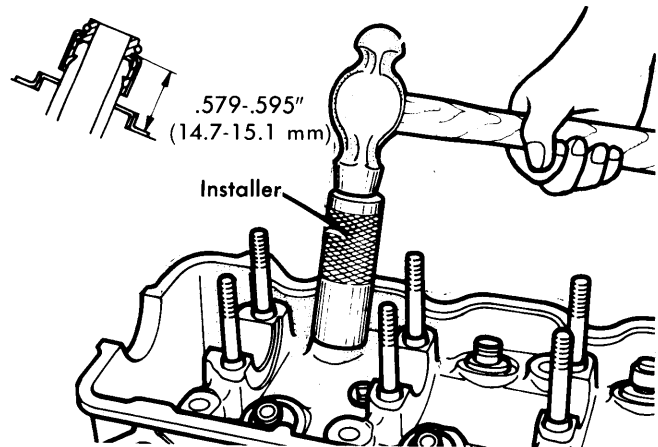

**Fig. 12 Valve Stem Oil Seal Installation and Height**

#### VALVE STEM OIL SEALS

After installing valve spring seat, place stem seal on guide. Use installer to lightly hammer seal into correct position as tool bottoms on head. Do NOT use old seals and do NOT twist seals when installing.

#### VALVE SEAT SERVICING

1) Check valve seat for damage or wear. Replace or rework seat, as necessary. If reworking seat, check valve guide first. Make proper replacement, if required, then check seat for necessary corrections.

## 1400, 1600, 2000 &amp; 2600 cc 4 CYLINDER (Cont.)

2) Recondition valve seat with suitable grinder or cutter to specified contact width. After rework, valve and seat should be lapped with suitable compound.

3) Valve seat sink (wear of seat inward allowing valve to seat too deep in head) must be checked by measuring installed height of spring between the spring seat and retainer with all spring components installed. Standard dimension is 1.590" (40.4 mm) with additional wear limit of .039" (1.0 mm). Replace valve seat if beyond limit.

4) Remove valve seat by thinning down with a suitable cutter, then machine seat bore to proper size for replacement seat. Heat head to approximately 480°F (250°C) and press in over-size seat. Replacement seats are available in .012" (.305 mm) and .024" (.610 mm) oversizes, marked "30" and "60" respectively.

## VALVE CLEARANCE ADJUSTMENT

1) Ensure timing marks on camshaft sprocket and chain are aligned. With head assembly installed, temporarily adjust valves (sequence for adjustment; 1-3-4-2), according to following procedure: At compression stroke TDC, for cylinder being adjusted, loosen rocker arm nuts; then, turning adjusting screw, adjust valve clearance to specifications.

2) Complete engine assembly and temporarily install rocker cover. Warm engine until coolant temperature is 170 to 180°F. With piston at TDC on compression stroke, back intake valve adjusting screw off 2 or more turns. Adjust jet valve clearance, then adjust intake valve clearance. Adjust exhaust valve clearance and assure that all adjusting screw lock nuts are tightened securely.

**NOTE** — Jet valve spring is comparatively weak and must not be forced in when making adjustment. Final valve clearance should be adjusted after cylinder head bolts have been tightened to final torque.

Application	Valve Clearance	
	Cold In. (mm)	Hot In. (mm)
Intake .....	.003 (.07)	.006 (.15)
Exhaust .....	.007 (.17)	.010 (.25)
Jet Valve .....	.003 (.07)	.006 (.15)

## PISTONS, PINS &amp; RINGS

## PISTON &amp; CONNECTING ROD ASSEMBLY

**Removal** — Remove cylinder head and oil pan. Check to ensure connecting rods and rod caps are marked to aid in assembling components to their original position. Remove carbon ridge from cylinder bores. Remove connecting rod caps. Remove connecting rod and piston assembly through top of cylinder block.

**Installation** — To reinstall, lubricate all internal surfaces with engine oil before installation. Make sure front mark on piston head faces front of engine. Use a ring compressor to compress rings (without changing their position) and install piston and connecting rod assembly in to cylinder block in their original position. Tap lightly on piston dome with wooden handle tool while guiding connecting rod onto crankshaft. Install rod cap onto proper piston and connecting rod assembly. Tighten attaching bolts. Install cylinder head and oil pan.

## FITTING PISTONS

1) After checking block for distortion, cracks, scratches or other abnormalities, measure bores at 3 levels. If any distortion exceeds .001" (.02 mm) from standard bore size, block must be rebored and oversize pistons installed.

**NOTE** — Pistons for all 4 engine sizes are available in standard, .010" (.25 mm), .020" (.50 mm), .030" (.75 mm) and .039" (1.0 mm) oversizes. Oversize pistons are stamped on crown to indicate oversize amount.

2) Check outside diameter of piston by measuring at a point .079" (2 mm) from bottom of skirt and at 90° to pin bore. Determine amount of cylinder reboring required to meet specified clearance.

## PISTON PINS

Check piston pin-to-bore fit; pin should press in smoothly by hand (at room temperature). When assembling, apply engine oil to outside of pin and to piston pin bore, position rod to piston ("FRONT" mark upward), align pin with pressing tool, and press pin into piston and rod.

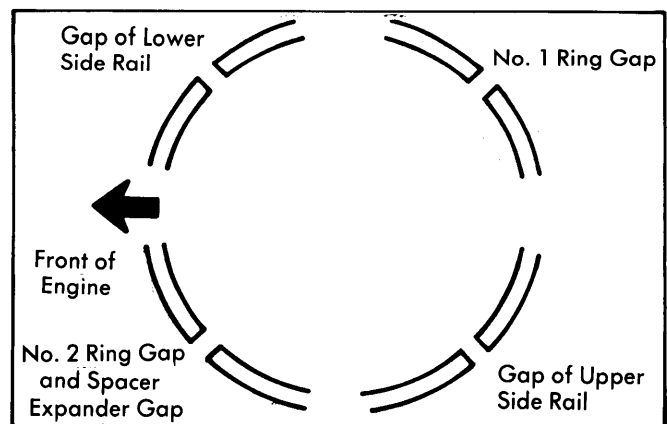

Fig. 13 Piston Ring Gap Positions

## PISTON RINGS

Measure piston ring side and end clearance for all pistons and replace rings as necessary. When replacing a ring without correcting the cylinder bore, check ring end gap at lower part of cylinder that is less worn. When replacing a ring, be sure to use one of the same size. Install rings on piston with end gaps staggered at 120° intervals, but make sure no ring gap is in line with thrust face of pin bore. Also be sure the manufacturer's marks are facing upward when rings are installed.

## 1400, 1600, 2000 & 2600 cc 4 CYLINDER (Cont.)

**CAUTION** — Install oil ring first *WITHOUT* using a ring expander. Spacer expander gap should be installed more than 45° from side rail gaps, and rails should turn smoothly when installed.

### Piston Ring Sizes

Ring Size	Size Mark
1400, 1600, 2000 & 2600 cc	
Standard .....	No Mark
.010" (.25 mm) OS .....	25
.020" (.50 mm) OS .....	50
.030" (.75 mm) OS .....	75
.039" (1.00 mm) OS .....	100

## CRANKSHAFT MAIN & CONNECTING ROD BEARINGS

### MAIN & CONNECTING ROD BEARINGS

1) Inspect each bearing for peeling, melting, seizure or improper contact. Replace defective bearings. Measure outside diameter of crankshaft and connecting rod journals to determine if out-of-round or tapered.

2) Cut Plastigage to same length as width of bearing. Place it parallel with journal (not over oil holes). Install crankshaft bearings and caps, tightening to specifications. Always install caps with arrow facing forward.

**NOTE** — Do not turn crankshaft with Plastigage installed.

3) Remove main bearing cap from crankshaft and measure Plastigage at widest part (using scale on Plastigage package). Repeat procedure for connecting rod bearings. If clearance exceeds limits, bearing should be replaced or undersize bearing installed. Undersize bearings are available in .010" (.25 mm), .020" (.50 mm), and .030" (.75 mm) undersizes.

### THRUST BEARING

With crankshaft bearing caps installed, check thrust clearance (end play) by inserting feeler gauge between center main bearing and crankshaft thrust face. If clearance exceeds specified limits, replace center main bearing.

## ENGINE OILING

### ENGINE OILING SYSTEM

All engines use force-feed type lubrication system. 1400 cc engine uses gear-crescent type pump, 1600 cc *WITHOUT* silent shaft uses a trochoid type pump, and all other engines use gear type pump. Driven gear of oil pump also drives counterbalance shaft on silent shaft engines.

Crankcase Capacity (Includes Filter)	
Application	Approximate Quantity
1400 cc .....	3.7 quarts
1600 cc .....	4.2 quarts
2000 cc .....	4.5 quarts
2600 cc .....	5.2 quarts

**Oil Pressure** — 50-64 psi @2000 RPM.

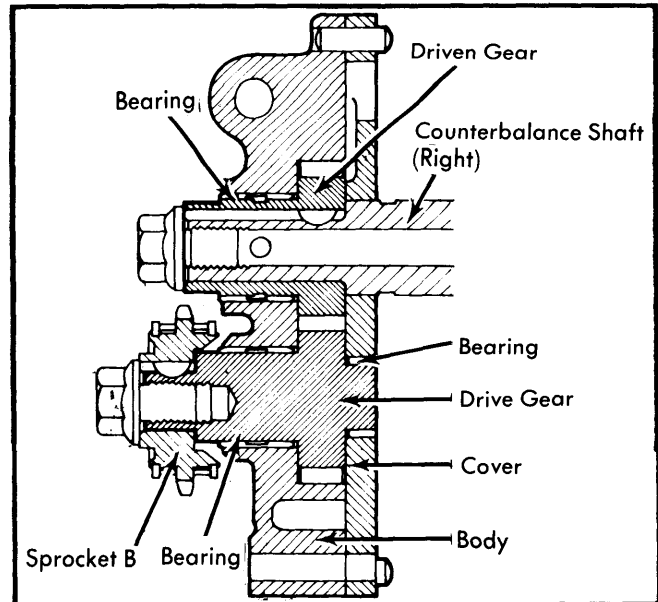

Fig. 14 Cutaway View of Gear Type Oil Pump

### OIL PUMP

**1400 cc** — Gear-crescent type pump is mounted on front of engine assembly and driven directly by the crankshaft. Oil pan, oil screen and timing belt must be removed prior to removing front cover-oil pump assembly. Remove 7 mounting bolts and remove pump assembly. Inspect gears, case and seal for wear or damage. Ensure that gears are assembled in same direction as originally installed. Use new gaskets and install pump and pan. Use suitable sealer at joint faces and seams.

**1600 cc (Without Silent Shaft)** — Mounted at lower left of engine, driven by camshaft drive belt. Cover and rotor assembly may be removed after removing drive sprocket by taking out cover bolts and lifting assembly out. May also be removed with engine front case as an assembly.

**1600 cc (With Silent Shaft)** — Gear type pump mounted at lower left front of engine. To remove, first insert screwdriver in plug hole at bottom left of block to prevent counterbalance from turning, then remove drive sprocket. Remove pump cover and bolt holding driven gear to counterbalance. Pump gears and left counterbalance shaft may be removed along with front case. Inspect and replace worn gears or cover. To install, assure that timing marks on pump are aligned, insert left counterbalance shaft in driven gear, and temporarily tighten bolt. Install left counterbalance shaft with front case and oil pump as an assembly.

**2000 & 2600 cc** — Pump is mounted at lower right side of engine block, and driven by countershaft drive chain. For removal, see *COUNTERBALANCE SHAFTS, 2000 & 2600 cc*. To install, reverse removal procedure, assuring that oil pump gear mating marks are aligned and that woodruff key on counterbalance shaft fits in keyway of driven gear.

**CAUTION** — Prior to installing oil pump (all models), fill with sufficient amount of engine oil to prime pump.

## 1400, 1600, 2000 & 2600 cc 4 CYLINDER (Cont.)

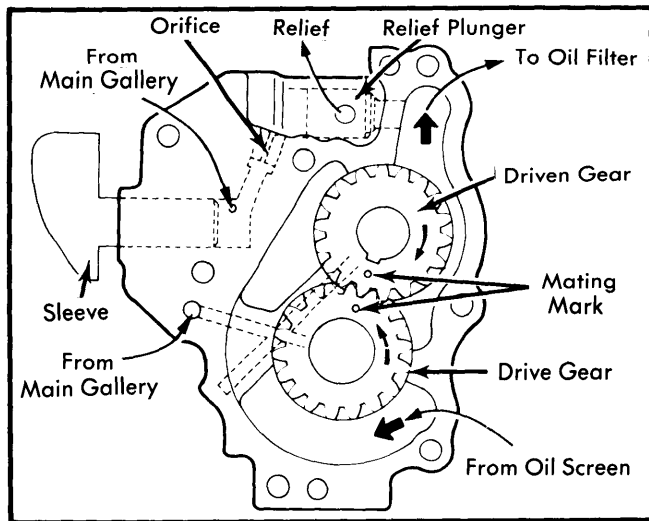

**Fig. 15 Mating Marks of Oil Pump Gears**

Application	Cooling System	Approximate Capacity
1400 cc .....		5.2 quarts
1600 cc .....		7.7 quarts
2000 cc .....		9.5 quarts
2600 cc .....		9.7 quarts

### WATER PUMP

**Removal & Installation (1400 & 1600 cc)** – Drain cooling system and disconnect battery. Remove drive belt, fan, pulley, and lower radiator hose to pump. Ensure that number 1 piston is at TDC on compression stroke, then remove camshaft pulley, timing belt covers, timing belt, camshaft sprocket, upper inner cover and timing belt tensioner. Remove mounting bolts and remove pump from engine. To install, use new gasket and reverse removal procedure.

**Removal & Installation (2000 & 2600 cc)** – Pump may be removed after drive belt, fan and pulley are removed by taking out mounting bolts. To install, use new gasket and reverse removal procedure.

Oil Pump Specifications	
Application	Clearance In. (mm)
<b>1400 cc Gear-Crescent Type</b>	
Outer Gear-to-Case .....	.0039-.0079 (.10-.20)
Outer Gear-to-Crescent .....	.0087-.0134 (.22-.34)
Gear End Play .....	.0016-.0039 (.04-.10)
Inner Gear-to-Crescent .....	.0083-.0126 (.21-.22)
<b>1600 cc Trochoid Type</b>	
Side Clearance .....	.0024-.0047 (.06-.12)
Tip Clearance .....	.0016-.0047 (.04-.12)
Body Clearance .....	.0039-.0063 (.10-.16)
Drive Shaft-to-Cover Clearance ..	.0008-.0020 (.02-.05)
<b>1600 cc Gear Type</b>	
Gear End Play .....	.0024-.0047 (.06-.12)
Gear Shaft-to-Pump Cover .....	.0008-.0019 (.02-.05)
Gear Tip-to-Body Clearance .....	.0039-.0078 (.1-.2)
Tip Clearance Between Gears .....	.0158-.0275 (.4-.7)
<b>2000 &amp; 2600 cc Gear Type</b>	
Gear Tip-to-Body Clearance ...	.0041-.0059 (.105-.150)
Gear End Play .....	.0024-.0047 (.06-.12)
Drive Gear-to-Bearing .....	.0008-.0018 (.02-.046)
Drive Gear-to-Rear Bearing ....	.0017-.0026 (.044-.066)

TIGHTENING SPECIFICATIONS		
Application	Ft. Lbs. (mkg)	
<b>Camshaft Bearing Cap</b>		
1600 cc .....	14-15 (1.9-2.0)	
2000 & 2600 cc .....	13-14 (1.8-1.9)	
<b>Camshaft Sprocket</b>		
1400 cc .....	47-54 (6.4-7.3)	
1600 cc .....	44-58 (6.0-8.0)	
2000 & 2600 cc .....	37-43 (5.1-5.9)	
<b>Cylinder Head Bolts (Cold)</b>		
1400 & 1600 cc .....	51-54 (7.0-7.5)	
2000 & 2600 cc .....	65-72 (9.0-9.9)	
<b>Main Bearing Caps</b>		
1400 & 1600 cc .....	37-39 (5.1-5.4)	
2000 & 2600 cc .....	55-61 (7.6-8.4)	
<b>Connecting Rod Caps</b>		
1400 & 1600 cc .....	24-25 (3.3-3.4)	
2000 & 2600 cc .....	33-34 (4.6-4.7)	
<b>Crank Pulley</b>		
1400 & 1600 cc .....	8-9 (1.1-1.2)	
2000 & 2600 cc .....	80-94 (11.0-13.0)	
<b>Crankshaft Sprocket Bolt</b>		
1400 cc .....	37-43 (4.9-5.8)	
1600 cc .....	44-50 (6.0-6.9)	
<b>Flywheel-to-Crankshaft</b> .....		94-101 (13.0-13.9)
<b>Drive Plate (A/T) to Crankshaft</b> .....		84-90 (11.6-12.4)
<b>Oil Pump/Cover</b>		
1600 cc .....	11-13 (1.5-1.8)	
1400, 2000 & 2600 cc .....	6-7 (.8-1.0)	
<b>Jet Valve</b> .....		13-15 (1.8-2.0)

### ENGINE COOLING

**Thermostat** – 180°F (82°C)

**Radiator Cap** – 12.8 psi (.88 kg/cm<sup>2</sup>).

## 1400, 1600, 2000 & 2600 cc 4 CYLINDER (Cont.)

### ENGINE SPECIFICATIONS

GENERAL SPECIFICATIONS										
Year	Displ.		Carburetor	HP at RPM	Torque (Ft. Lbs. at RPM)	Compr. Ratio	Bore		Stroke	
	cu. ins.	cc					in.	mm	in.	mm
1979	86.0	1400	2-Bbl.	70@5200	78@3000	8.8:1	2.91	74	3.23	82
	97.5	1600	2-Bbl.	77@5200	87@3000	8.5:1	3.03	77	3.39	86
	121.7	2000	2-Bbl.	93@5200	108@3000	8.5:1	3.31	84	3.54	90
	155.9	2600	2-Bbl.	105@5000	139@2500	8.2:1	3.59	91	3.86	98

VALVES							
Engine & Valve ①	Head Diam. In. (mm)	Face Angle	Seat Angle	Seat Width In. (mm)	Stem Diameter In. (mm)	Stem Clearance In. (mm)	Valve Lift In. (mm)
1400 cc Intake	1.34 (34)	45°	45°	.035-.051 (.9-1.3)	.315 (8.0)	.001-.002 (.03-.06)	.346 (8.8)
	1.18 (30)	45°	45°	.047-.063 (1.2-1.6)	.315 (8.0)	.002-.004 (.06-.10)	.346 (8.8)
1600 cc Intake	1.50 (38)	45°	45°	.035-.051 (.9-1.3)	.315 (8.0)	.001-.002 (.03-.06)	.362 (9.2)
	1.22 (31)	45°	45°	.035-.051 (.9-1.3)	.315 (8.0)	.002-.004 (.06-.10)	.362 (9.2)
2000 & 2600 cc Intake	1.70 (43)	45°	45°	.035-.051 (.9-1.3)	.315 (8.0)	.001-.002 (.03-.06)	.393② (10.0)
	1.38 (35)	45°	45°	.035-.051 (.9-1.3)	.315 (8.0)	.002-.004 (.06-.10)	.393 (10.0)

① — Jet valve and body not individually serviceable. Replace as an assembly when defective.

② — 2600 cc valve lift .413" (10.5 mm)

PISTONS, PINS, RINGS						
Engine	PISTONS Clearance In. (mm)	PINS		RINGS		
		Piston Fit In. (mm)	Rod Fit In. (mm)	Rings	End Gap In. (mm)	Side Clearance In. (mm)
1400 & 1600 cc	.0008-.0016 (.02-.04)	①	Locked in Rod	No. 1	.008-.016 (.2-.4)	.0012-.0028 (.03-.07)
				No. 2	.008-.016 (.2-.4)	.0008-.0024 (.02-.06)
				Oil	.008-.020 (.2-.5)	.....
2000 & 2600 cc	.0008-.0016 (.02-.04)	①	Locked in Rod	No. 1	.010-.018 (.25-.45)	.0024-.0039 (.06-.10)
				No. 2	.010-.018 (.25-.45)	.0008-.0024 (.02-.06)
				Oil	.008-.035 (.2-.9)	.....

① — Thumb press fit without rod installed

# Chrysler Corp. Import Engines

## 1400, 1600, 2000 & 2600 cc 4 CYLINDER (Cont.)

### ENGINE SPECIFICATIONS (Cont.)

CRANKSHAFT MAIN & CONNECTING ROD BEARINGS							
Engine	MAIN BEARINGS				CONNECTING ROD BEARINGS		
	Journal Diam. In. (mm)	Clearance In. (mm)	Thrust Bearing	Crankshaft End Play In. (mm)	Journal Diam. In. (mm)	Clearance In. (mm)	Side Play In. (mm)
1400 cc	1.890 (48)	.0008-.0028 (.02-.07)	No. 3	.002-.007 (.05-.18)	1.653 (42)	.0004-.0024 (.01-.06)	.004-.01 (.10-.25)
1600 cc	2.244 (57)	.0008-.0028 (.02-.07)	No. 3	.002-.007 (.05-.18)	1.772 (45)	.0004-.0024 (.01-.06)	.004-.01 (.10-.25)
2000 & 2600 cc	2.598 (66)	.0008-.0028 (.02-.07)	No. 3	.002-.007 (.05-.18)	2.087 (53)	.0008-.0028 (.02-.06)	.004-.01 (.10-.25)

CAMSHAFT			
Engine	Cam Lobe Height In. (mm)ⓐ	End Play In. (mm)	Lobe Lift In. (mm)
1400 cc Int. & Exh.	1.5 (38.1)	.002-.004 (.05-.10)	.....
1600 cc Int. & Exh.	1.433 (36.4)	.002-.006 (.05-.15)	.359 (9.2)
2000 & 2600 cc Int. & Exh.	1.661 (42.2)	.004-.008 (.10-.20)	.393 (10.0)

VALVE SPRINGS			
Engine	Free Length In. (mm)	PRESSURE Lbs. @ In. (kg @ mm)	
		Valve Closed	Valve Open
1400 cc	1.697 (43.1)	69@1.417 (31.1@36)	.....
1600 cc	1.823 (46.3)	61.7@1.469 (27.9@37.3)	.....
2000 & 2600 cc	1.869 (47.5)	61@1.59 (27.6@40.4)	.....

ⓐ — Maximum wear limit .020" (.5 mm).