

# Drive Axles

## TRIUMPH SEPARATE CARRIER (I.R.S.)

Spitfire

### DESCRIPTION

Rear axle is an independent rear suspension type with hypoid gears and a separate differential carrier. Inner and outer axles are carried by ball bearings. Pinion shaft and differential are carried by taper roller bearings. Preloading and backlash adjustment to these bearings is made by the use of selective shims.

**NOTE** — Late models use a collapsible spacer instead of shims for the pinion drive.

### AXLE RATIO & IDENTIFICATION

To determine ratio, divide ring gear teeth by pinion gear teeth.

Model	Axle Ratio
Spitfire 1500 .....	①3.89:1

① — Pinion 9 teeth, Ring Gear 35 teeth.

### REMOVAL & INSTALLATION

#### AXLE SHAFTS & BEARINGS

**Removal Outer Axle** — 1) Jack up rear of vehicle and support on floor stands. Remove wheel and brake drum.

Disconnect brake line at chassis and wheel cylinder. Disconnect parking brake cable at backing plate and release return spring. Using a jack under vertical link to relieve shock absorber load, remove bolt attaching radius arm to link bracket.

2) At inner drive axle flange, disconnect "U" joint by removing four bolts. Disconnect lower shock mount at vertical link. Remove jack while supporting axle assembly by hand. Remove bolt attaching road spring to vertical link and withdraw axle assembly and link.

3) Remove wheel hub flange nut from axle. Using suitable puller (S109C), remove hub flange and Woodruff key. Remove bolt attaching vertical link to bearing housing. Remove four bolts attaching grease trap, backing plate and seal holder.

4) Using suitable tool (S4221A & -14), press axle shaft from bearing housing. With a drift or press, drive out oil seal and needle bearing, noting direction seal and needle bearing are facing. Drive out ball bearing at opposite end of housing.

**Installation Outer Axle** — 1) Using suitable tool (S300A), press needle bearing into housing to a depth of .50" (12.7 mm) below housing face. Press seal into housing. Pack needle bearing with grease and slide housing onto axle shaft.

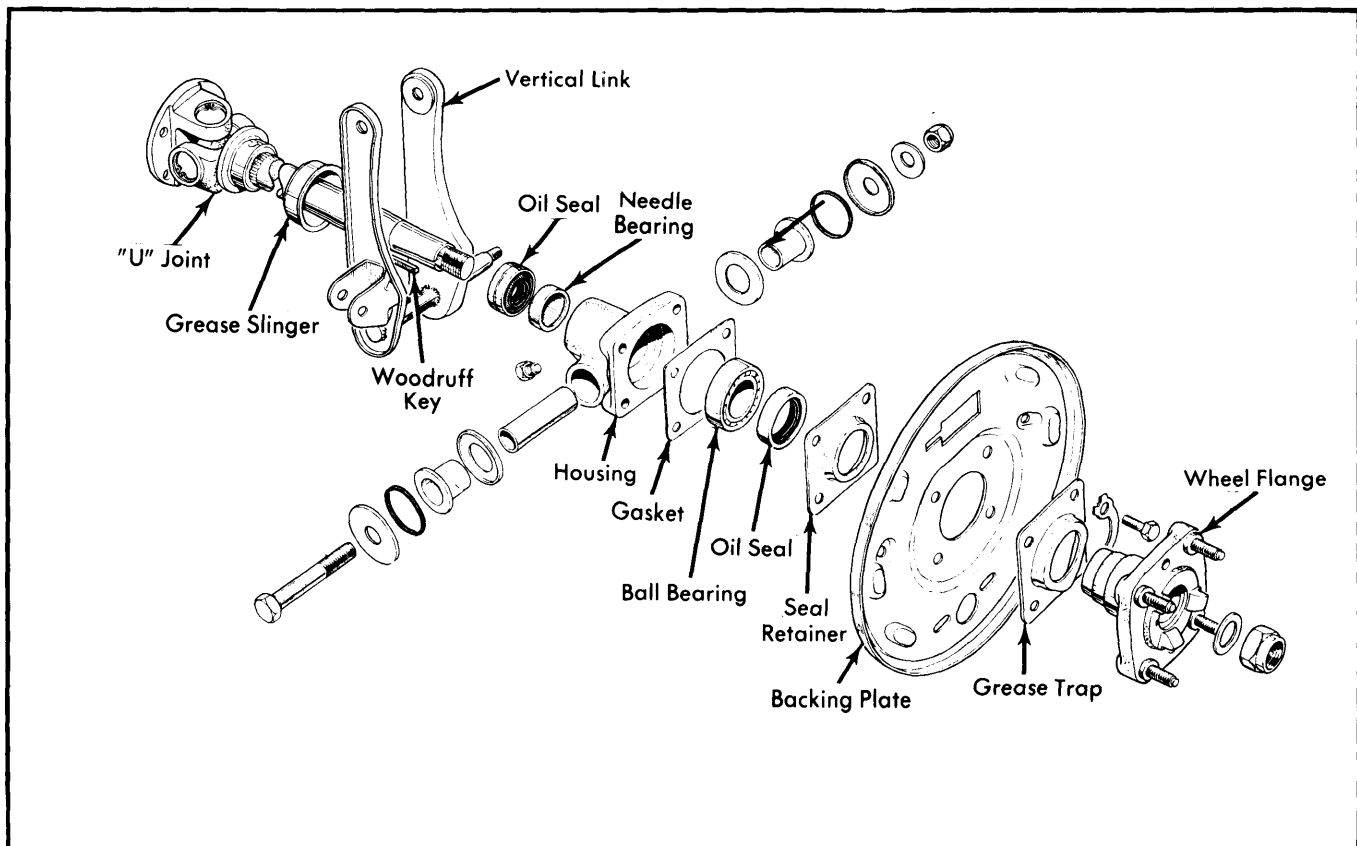

Fig. 1 Exploded View of Triumph Spitfire Outer Axle Assembly

## TRIUMPH SEPARATE CARRIER (I.R.S.) (Cont.)

2) Holding axle in a soft jawed vice, drive ball bearing onto axle shaft using suitable tool (S304). Pack ball bearing and housing with grease and tap bearing into housing. Install gasket, seal, seal housing, backing plate and grease trap and tighten attaching bolts.

3) Install Woodruff key and wheel flange. Using a plain washer and a new locknut, tighten nut to specifications. Bolt axle assembly to vertical link with nut to the rear. Fit vertical link and axle assembly to spring eye with nut to the rear (Do not tighten).

4) Jack up assembly and attach shock absorber. Connect radius arm to vertical link. Using new lock nuts, attach "U" joint to inner axle flange. Attach parking brake cable and reconnect return spring. Connect brake line and bleed hydraulic system. Install brake drum and wheel. Remove floor stands and roll vehicle to settle suspension. Finally tighten spring eye bolt.

**Removal Inner Axle** - 1) With outer axle assembly removed, remove Allen screws retaining seal housing plate. If

both inner axle shafts are to be removed, mark shafts for correct reassembly. Place a pan under differential case to catch grease. Withdraw axle shaft complete with bearing and oil seal housing.

2) Remove circlip locating bearing. Using suitable tools (S4221A & -7B), press axle shaft from bearing. Remove seal housing plate and drive out seal.

**Installation Inner Axle** - 1) Press oil seal into seal housing plate so that lip of seal will face differential case when assembled. Carefully slide seal and housing over axle shaft. Using suitable tool (S4221A), press axle shaft through bearing until circlip groove is completely exposed.

2) Install circlip in axle groove. Lubricate shaft splines and bearing. Apply suitable joint compound to seal plate. Slide axle shaft into differential case and make sure shaft splines engage with differential side gear splines. Install and tighten Allen screws.

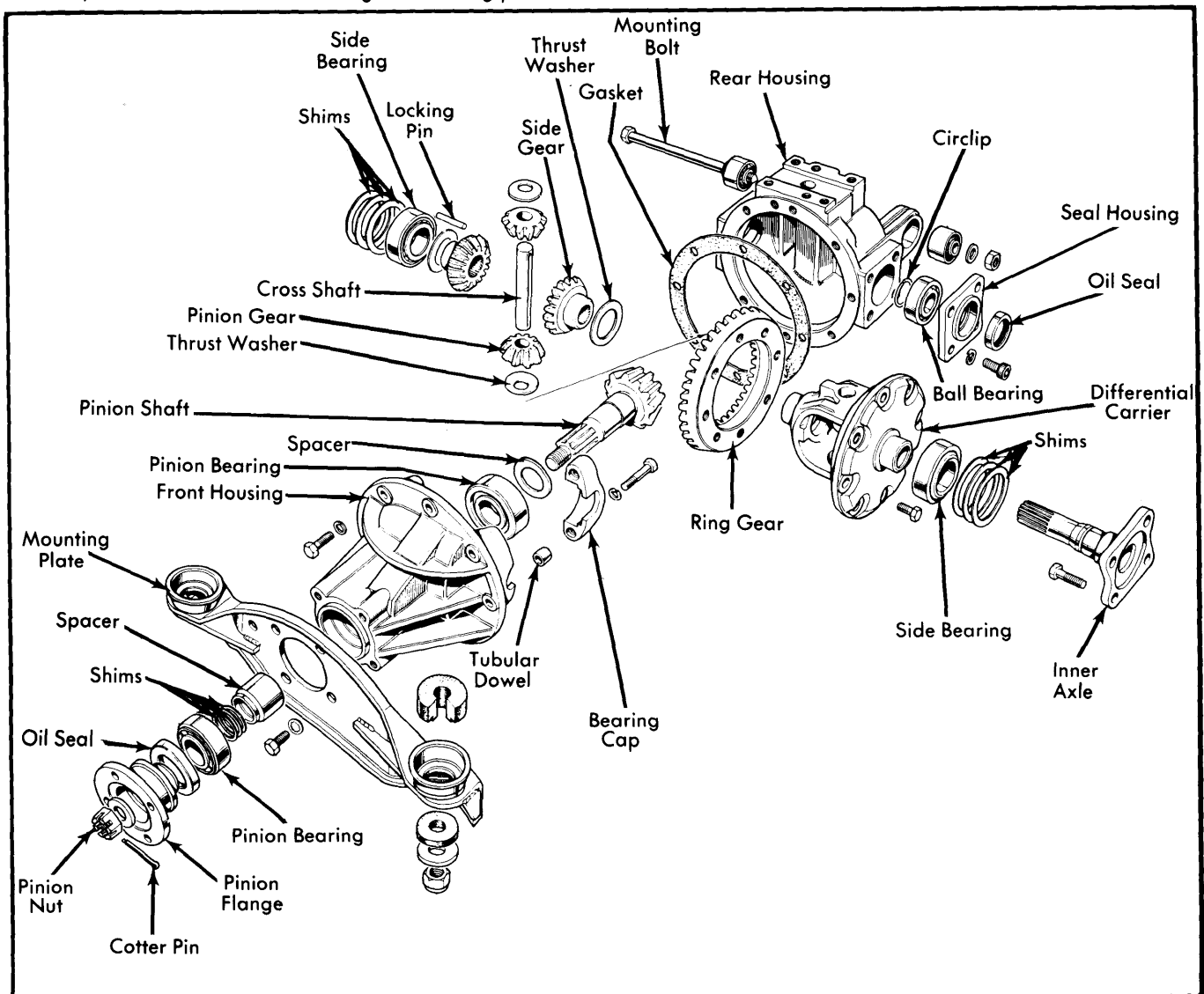

Fig. 2 Exploded View of Inner Axles and Differential Assembly

## TRIUMPH SEPARATE CARRIER (I.R.S.) (Cont.)

### PINION FLANGE & SEAL

**Removal** — Raise vehicle on a hoist and remove muffler. Mark propeller shaft and pinion flange for correct reassembly. Disconnect propeller shaft and place aside. Remove cotter pin and install suitable flange holder tool (S337 or RG421). Place a pan under differential case to catch grease and remove pinion nut and flange. Pry out old seal.

**Installation** — Soak oil seal in light oil for approximately an hour. With seal lip facing pinion bearing, drive seal into housing. Install pinion flange and tighten pinion nut. Install new cotter pin and connect propeller shaft, making sure marks are aligned. Replace muffler, add lubricant and remove vehicle from hoist.

### AXLE ASSEMBLY

**NOTE** — The following removal procedure is for inner axles and differential assembly only. For outer axle assemblies, See Axle Shafts & Bearings.

**Removal** — 1) Jack up vehicle and place on floor stands. Remove muffler and tail pipe. Mark pinion flange and propeller shaft for reassembly. Disconnect propeller shaft and set aside. Disconnect outer axle "U" joints at inner axle flanges.

2) Remove rear trim panel and rear spring access cover. Remove nuts and studs attaching rear spring to differential case assembly. Remove differential case rear mounting nut and bolt. While supporting assembly, remove two nuts attaching front mounting plate to chassis. Holding assembly upright to avoid grease spillage, remove assembly from vehicle.

**Installation** — To install, reverse removal procedures noting the following: Locate dowel pin in bottom spring leaf so that it engages hole in differential case. Make sure rubber washers are mounted on outside of rear mounting lugs.

### OVERHAUL

**NOTE** — This procedure assumes inner and outer axles removed from differential assembly and assembly removed from vehicle. For axle removal, See Axle Shafts & Bearings.

### DISASSEMBLY

1) Remove bolts and lock washers joining front and rear differential housings. Remove front housing and differential carrier from rear housing. Place differential housing in a vice and mark bearing caps for reassembly. Remove bearing caps.

2) Install suitable differential spreader (S101 & -1) to differential housing. Spread housing and pry out differential carrier. **CAUTION** — Do not exceed .008" (.20 mm) spread of housing or damage to case may occur. Using suitable tools (18G47C & -BD), press carrier bearings from carrier assembly.

3) Mark ring gear and carrier for proper reassembly. Remove ring gear and drive out cross shaft locking pin. Push out pinion cross shaft and rotate pinion gears 90° to carrier opening. Remove pinion gears and side gears with their thrust washers.

4) Remove cotter pin from pinion shaft. Using suitable flange holder (RG421 or S337), remove pinion shaft nut and flange. Press out pinion shaft and remove shims and spacer. Using suitable tools (S4221A & -17), press bearing from pinion shaft. With a drift, drive out bearing races and oil seal from pinion housing.

**NOTE** — Ring and pinion gears are replaced as a matched set only. Numbers etched on each gear must be the same.

### REASSEMBLY & ADJUSTMENT

**Drive Pinion Depth** — 1) Press inner and outer bearing races into pinion housing. Place inner pinion bearing on dummy pinion shaft (18G 191 M). **NOTE** — The standard pinion bearing spacer, .077" (1.95 mm), is incorporated in dummy pinion. Oil bearings and install dummy pinion, outer bearing, tool spacer, washer and nut into pinion housing.

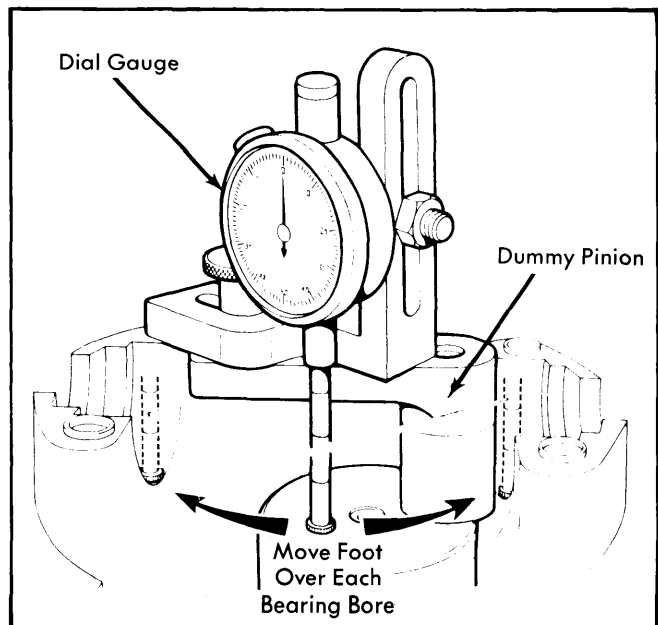

Fig. 3 Measuring Drive Pinion Depth

2) Gradually tighten nut until a bearing preload of 15-18 INCH lbs. (.17-.21 mkg) of rotating torque is obtained. Mount a dial indicator on pinion housing so foot of indicator will contact head of dummy pinion. Zero dial indicator.

3) Move indicator foot over center of each differential bearing bore and take a dial reading. Add two dial readings together and divide by two. The result will either be added or subtracted to standard spacer thickness, .077" (1.95 mm), depending on whether pinion is high or low in housing. Select a spacer washer of correct thickness for pinion assembly.

**NOTE** — Twenty two pinion head washers are available in sizes ranging from .075-.096" (1.91-2.44 mm). Ignore +, -, or "N" markings on pinion, they are taken into consideration in design and method of using dummy pinion.

4) Remove dummy pinion from pinion housing. Press inner bearing from dummy pinion.

## TRIUMPH SEPARATE CARRIER (I.R.S.) (Cont.)

**Pinion Bearing Preload** – 1) Place selected pinion depth washer on pinion and install inner bearing onto pinion. Oil bearing and install drive pinion gear in housing.

2) Install collapsible spacer and outer pinion bearing on pinion shaft. Install oil seal with lips of seal towards pinion gear head. Install flange, washer, and nut, but do not tighten nut.

3) While gradually tightening nut, keep checking the pinion bearing preload using an inch pound torque wrench. Tighten nut as required to obtain specified pinion bearing preload. Initial preload is 15-18 INCH lbs (17.3-20.8 cmkg).

**CAUTION** – If pinion bearing preload torque specification is exceeded, a new collapsible spacer will be required and this procedure repeated.

**Case Assembly** – 1) Using suitable tool (550 and 18G134-DH), press differential bearings onto carrier housing. Install thrust washers and side gears into carrier. Place pinion gears in carrier meshed with side gears. Using an axle shaft, rotate side gears until cross shaft can be inserted through carrier and pinion gears.

2) Press pinion gears fully into mesh with side gears. Using a dial indicator, measure for run out to determine needed thrust washer thickness. Remove cross shaft and pinion gears.

3) Install thrust washers (22 sizes available), pinion gears and cross shaft. Gear backlash should be "0". If required, adjust thrust washers until pinion gear end play results in "0" gear backlash. Install cross shaft locking pin and peen over edge of pin hole.

**Backlash & Side Bearing Preload** – 1) After checking for burrs, mount ring gear to carrier, using Loctite on the bolts. Install bearing caps and measure ring gear runout.

2) Before installing pinion shaft, measure "Total End Play" of carrier assembly as follows: Mount a dial indicator so foot will touch rear side of ring gear. With bearing caps removed, push carrier fully to one side of case and zero dial indicator. Move carrier fully in the opposite direction and note total end play measurement for further use.

3) With pinion shaft installed, fully move ring gear into mesh with pinion gear and zero dial indicator. Move carrier assembly fully in opposite direction until ring gear side bearing is butted in its housing. Note "In-Out" mesh clearance for following example calculations.

### Ring Gear Backlash Calculations

"In-Out" Mesh Clearance	.025" (.63 mm)
Minus Backlash	.005" (.13 mm)
Ring Gear Side Shim Pack	①.020" (.50 mm)
Total End Play	.060" (1.52 mm)
Minus Ring Gear Side Shim Pack	.020" (.50 mm)
Caged Side Shim Pack	①.040" (1.02 mm)

① – For preload, add .002" (.051 mm) to each shim pack.

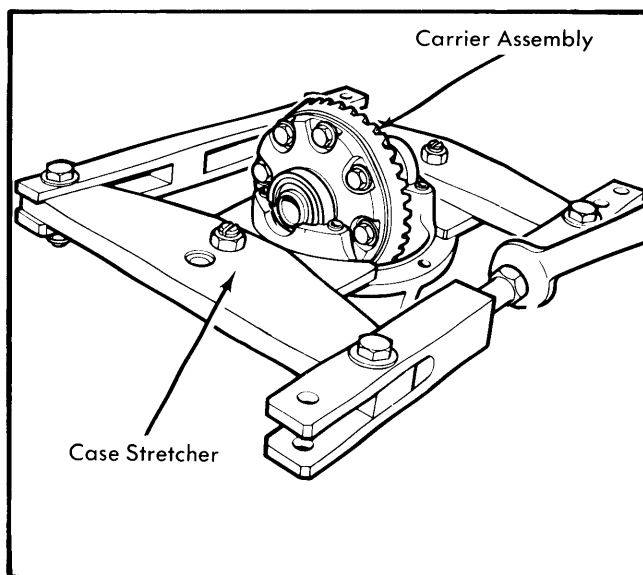

**Fig. 4 Using Case Stretcher to Install Carrier Assembly**

4) Install suitable case stretcher (S101 & -1) and spread just enough to install carrier assembly and shims. Remove case stretcher. Install bearing caps to their original positions and tighten bolts. With a dial indicator measure ring gear backlash at several points. If backlash is not to specifications, remove shims for one side and add to other side until correct backlash is achieved.

**NOTE** – A movement of .002" (.05 mm) shim thickness from one differential bearing to the other will vary backlash approximately .002" (.04 mm).

**Final Inspection & Assembly** – Make a tooth contact pattern check to assure proper running mesh. Using a suitable gasket compound, install gasket and front housing on rear housing and tighten attaching bolts.

### AXLE ASSEMBLY SPECIFICATIONS

Pinion Bearing Preload	13-20 INCH Lbs. (15-23 cmkg)
Differential Gear Backlash	"0"
Ring Gear Backlash	.004-.006" (.10-.15 mm)
Ring Gear Runout	.003" (.076 mm) max.

### TIGHTENING SPECIFICATIONS

Application	Ft. Lbs. (mkg)
Pinion Shaft Nut	90 (12.4)
Axle Shaft Flange Nut	90-120 (12.4-16.6)
Front-to-Rear Axle Housing	15-20 (2.1-2.8)
Spring-to-Axle Housing	26-34 (3.6-4.7)
Front Mount-to-Chassis	26-34 (3.6-4.7)
Axle Assembly-to-Vertical Link	38-48 (5.2-6.6)
Radius Arm-to-Vertical Link	24-32 (3.3-4.4)
Spring Eye Bolt	38-48 (5.2-6.6)