

DATSUN SEPARATE CARRIER

200SX
B210
510
620 (Pickup)
810 Station Wagon

DESCRIPTION

Differential gear carrier assembly has a hypoid type pinion and ring gear set. The gear carrier is constructed of cast iron. The drive pinion is mounted in two tapered roller bearings that are preloaded by a collapsible spacer or by non-adjustable spacer. Drive pinion is aligned into position with a shim located between shoulder on drive pinion and rear bearing. Differential case is supported in carrier by two tapered roller side bearings. The side bearings are preloaded by inserting shims between bearings and differential. Case houses two side gears that mesh with two pinion gears mounted on a pinion shaft. The pinion shaft is held in case with a lock pin. Pinions and side gears are set in front of thrust washers.

AXLE RATIO & IDENTIFICATION

Datsun does not identify rear axle with a particular outside identification marking, however all models use same basic type of removable carrier rear axle. It should be noted that part or model numbers may vary between vehicle models, but the internal design is similar. Various axle ratios are available depending on model and whether manual or automatic transmission equipped. Ratio may be determined by dividing number of ring gear teeth by number of pinion gear teeth.

REMOVAL & INSTALLATION

AXLE SHAFTS & BEARINGS

Removal — Raise and support vehicle. Remove rear wheels and brake drums. Disconnect parking brake linkage. Disconnect and plug brake line openings. Remove brake back plate retaining nuts and pull assembly from housing using a slide hammer.

Disassembly — Mount axle shaft assembly in vise or suitable mounting fixture and cut bearing collar with chisel. On model 620, bend lock tabs away and remove wheel bearing lock nut. Remove wheel bearing with brake back plate using suitable puller.

NOTE — Axle bearings on 620 models are tapered roller type. Outer race may be removed from back plate after removing oil seal by tapping out with a brass drift.

Reassembly — On 620 only, fit bearing outer race into position in backplate using brass drift and install oil seal. Pack seal lips with grease and install bearing and nut lock washers, then tighten lock nut to 108-145 ft. lbs. (15-20 mkg). Bend up lock tabs on washer. On all except 620, install bearing spacer, bearing and new collar using suitable press.

Installation — Apply wheel bearing grease in recess of axle case end. Install axle shaft after first replacing oil seal in axle housing. Ensure seal is not damaged during installation. Adjust axial end play using proper shim pack. To complete installation, reverse removal procedure.

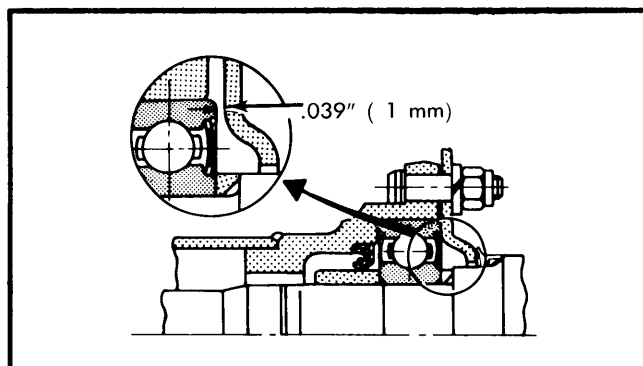

Fig. 2 Location for Checking Clearance Between Wheel Bearing and Axle Tube

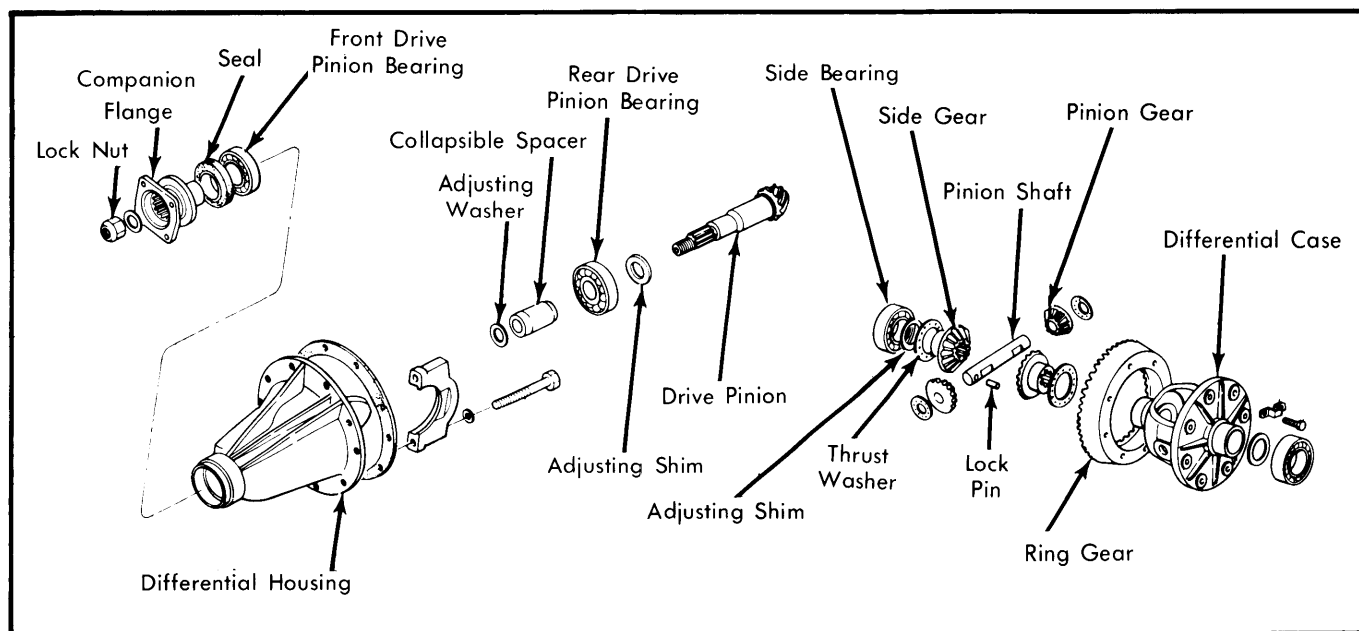

Fig. 1 Exploded View of Datsun Separate Carrier Differential Assembly

DATSUN SEPARATE CARRIER (Cont.)

PINION FLANGE SEAL

NOTE - The following procedure can only be performed on those models that use non-adjustable spacer (not collapsible spacer type).

Removal - Raise and support rear end of vehicle, then drain gear oil. Index mark propeller shaft and companion flange, then detach shaft and wire out-of-way. Remove drive pinion nut and companion flange. Remove oil seal.

Installation - Set new oil seal into position and pack grease between seal lips. Position companion flange and flat washer on drive pinion, then tighten nut and check bearing preload.

DIFFERENTIAL CARRIER

Removal - Raise and support vehicle on safety stands placed under rear axle housing. Drain gear lubricant. Index mark propeller shaft and remove. Withdraw rear axle shafts as previously described. Remove nuts mounting differential gear carrier to rear axle housing and lift out gear carrier.

Installation - To install differential gear carrier, reverse removal procedure and tighten nuts.

AXLE ASSEMBLY

Removal - Raise rear of vehicle and place on safety stands. Place a floor jack under center of axle housing. Remove rear wheels. Index mark propeller shaft and companion flange so components can be realigned in original position. Disconnect bolts mounting propeller shaft and carefully guide shaft from vehicle. Separate parking brake linkage at rear coupling and place forward out-of-way. Disconnect brake line rear union and plug opening. Disconnect shock absorbers at lower mount and compress until clear. Lower jack under axle housing and remove nuts and U-bolts securing leaf springs. With axle housing balanced on floor jack, carefully maneuver from vehicle.

Installation - To install axle housing, reverse removal procedure noting the following: Ensure propeller shaft index marks are properly aligned. Be sure U-bolts are not twisted over axle housing and that vehicle weight is on wheels when lower end of shock absorber is tightened.

OVERHAUL

DISASSEMBLY

NOTE - Predisassembly inspection of ring gear backlash and gear tooth contact can indicate where possible problems may be oriented. See Gear Tooth Contact at beginning of this section.

1) With differential carrier mounted in suitable work stand, index mark side bearing caps and carrier. Remove bearing caps and lift out differential assembly. Remove drive pinion lock nut and pull companion flange off using a gear puller. Remove drive pinion together with rear bearing inner race, spacer and washer. Drive pinion can be freed by tapping front end of assembly. If necessary, extract oil seal and withdraw front bearing inner race.

2) Use suitable puller (ST30031000) and extract bearing from drive pinion gear. Remove front and rear bearing races using a drift. Disassemble differential gear case as follows: Using

suitable puller (ST33051001) remove side bearings. Keep right and left side components separate for reassembly. Bend back ring gear retaining bolt lock tabs and remove bolts by loosening in a diagonal sequence. Drive out pinion shaft lock pin and remove pinion gears, side gears, and thrust washers. Identify gears and thrust washers for proper reassembly.

INSPECTION

Thoroughly clean all disassembled parts and visually inspect for excessive wear. Check all gears for wear and replace when necessary. **NOTE** - Drive pinion and ring gear are replaced only as a set. Inspect thrust washer surfaces and be sure they are free from surface scratches.

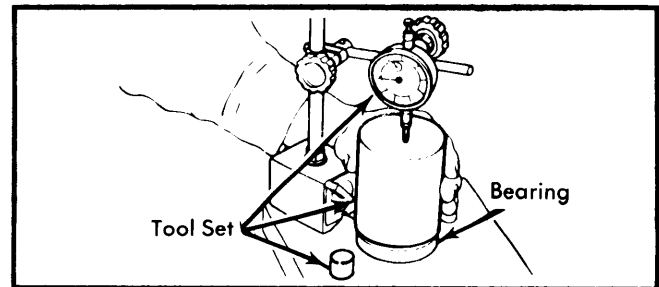

Fig. 3 Measuring Side Bearing Thickness

REASSEMBLY

Case Assembly - Fit pinion and side gears and thrust washers in differential case. Assemble pinion shaft to differential case so lock pin holes align with shaft. Inserting proper side gear thrust washers, obtain specified clearance between rear face of side gear and thrust washer. Insert pinion shaft lock pin and using a punch, secure into place. Lightly oil gear tooth areas and all thrust surfaces, then check that they are free to turn smoothly. Fit ring gear on differential case, tighten bolts diagonally, and bend over lock tabs. If side bearing is to be replaced, measure thickness of new ones using suitable tool set as shown in illustration. Normal bearing thickness should be as specified. Using suitable press, seat side bearing cone into differential case.

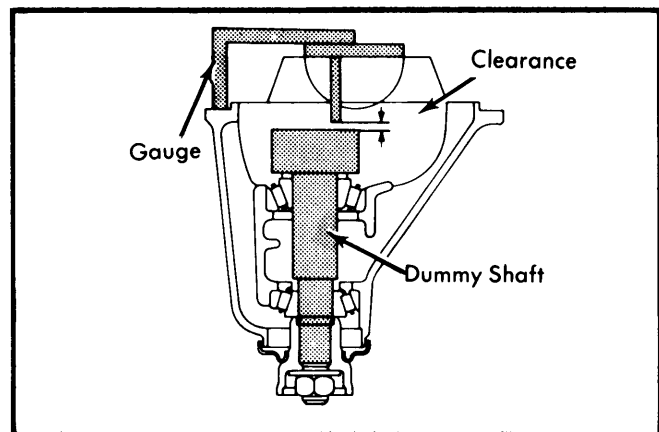

Fig. 4 Checking Drive Pinion Height Adjustment

Drive Pinion Height - Pinion height is adjusted with drive pinion adjusting washer placed behind the drive pinion gear. Variation from the standard size to the drive gear center is marked on drive pinion gear head. If tolerance is greater than standard size, number is marked in "+", if less than standard size, marking is "-". Install front and rear drive pinion outer races in gear carrier. Fit drive pinion adjusting washers and

DATSUN SEPARATE CARRIER (Cont.)

rear bearing on suitable dummy shaft. Position dummy shaft in final drive housing without drive pinion adjusting spacer, then put on front pinion bearing and companion flange. Tighten drive pinion nut to specified preload setting. Ensure not to overtighten drive pinion nut. Fit suitable drive pinion height gauge on final drive housing and measure clearance between end of gauge and surface of dummy shaft as shown in illustration. To calculate thickness of needed drive pinion adjusting washer, use one of the following formulas:

B210	$T = W + N - .01H - .18$
200SX & 510	$T = N - .01(H - D - S) + 2.98$
620 & 810	$T = N - .01(H - D - S) + 2.18$

T = Thickness of needed shim.
W = Thickness of temporary shim.
N = Clearance between depth gauge and dummy shaft.
H = Figure stamped on drive pinion head.
D = Figure stamped on dummy shaft.
S = Figure marked on height gauge.

NOTE — Formula values are expressed in millimeters.

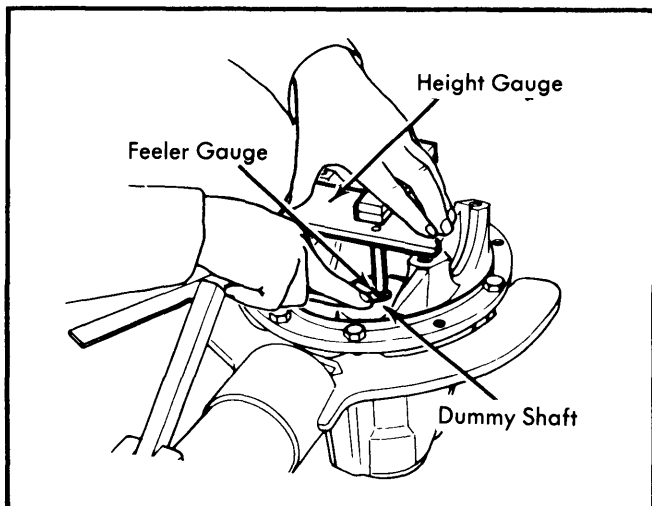

Fig. 5 Measuring Clearance Between Height Gauge and Dummy Shaft

Remove dummy shaft from gear carrier, take out pinion rear bearing from dummy shaft, select correct shims based on calculations and refit pinion rear bearing and drive pinion. Ensure face side of shims are toward back of pinion gear.

Drive Pinion Preload, Non-Collapsible Spacer Type — Adjustment of drive pinion preload is accomplished with spacer and washers placed between front and rear inner bearing races. **NOTE** — Adjustment must be performed without oil seal installed. Proceed with adjustment as follows: Liberally lubricate pinion bearings and install in the following order; drive pinion, spacer, washer, front inner race, companion flange and flat washer. Tighten nut to specified torque. Rotate pinion by hand so pinion nut is not over tightened. Increase spacer and washer thickness when pinion will no longer turn. Using a suitable pinion bearing preload gauge, determine the correct washer and spacer needed to provide specified preload. Spacers and washers are available in various sizes. Insert proper spacer and washer and again check preload. If preload is within specifications, remove drive pinion nut and companion flange, then press in a new oil seal. Install companion flange and tighten nut.

Drive Pinion Preload, Collapsible Spacer Type — After obtaining final pinion bearing height, lubricate front bearing and place into carrier. Fit new oil seal in carrier and fill space between seal lips with grease. Slip new collapsible spacer on drive pinion, then lubricate pinion rear bearing. Insert companion flange in oil seal while holding flange tightly against pinion front bearing cone. Working from back of carrier, insert drive pinion into the companion flange. Ensure drive pinion threads and mounting nut are dirt free, then holding companion flange, tighten nut. This step will pull drive pinion into front bearing cone and flange. When drive pinion is pulled into front bearing cone bearing end play will be reduced. With end play still in evidence, companion flange will be felt bottoming on collapsible spacer. Slowly turn nut and continuously check end play to ensure bearing preload does not exceed specifications. When end play is eliminated final preload is being approached. Turn pinion in both directions to set bearing. Adjust bearing preload to specifications using suitable INCH Lb. or cmkg. torque wrench.

NOTE — Never try to decrease bearing preload by backing off pinion nut; always replace collapsible spacer.

Backlash & Side Bearing Preload — 1) Preload is adjusted with shims. Procedure is done after overhaul work has been completed on differential assembly. When assembling without changing side bearings, install shims of original thickness. If bearings are being replaced, use the following formula to determine the required thickness of adjusting shims:

B210	$T1 = (A - C + D - H') \times .01 + .20 + E$
	$T2 = (B - D + H') \times .01 + .20 + F$

200SX & 510	$T1 = (A - C + D - H') \times .01 + .20 + E$
	$T2 = (B - D + H') \times .01 + .09 + F$

620 & 810	$T1 = (A - C + D - H') \times .01 + .175 + E$
	$T2 = (B - D + H') \times .01 + .150 + F$

T1 = Left shim thickness.
T2 = Right shim thickness.
A = Figure marked on left bearing carrier.
B = Figure marked on right bearing carrier.
C & D = Figure stamped on differential case (+ or - number).
E & F = Deviation from standard bearing thickness.
H' = Figure stamped on ring gear.

NOTE — Formula values are expressed in millimeters.

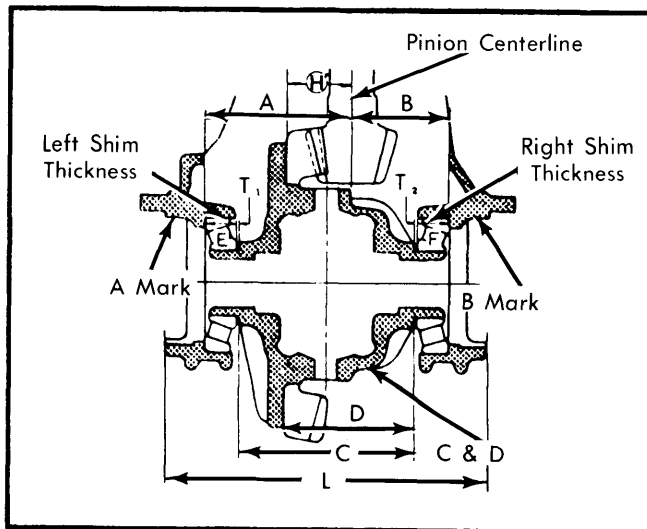

Fig. 6 Calculating Side Bearing Shim Thickness

DATSUN SEPARATE CARRIER (Cont.)

2) Side bearing thickness is measured using a suitable press (ST3250S0000) and applying approximately 5.5 lbs. (2.5 kg). Measure thickness in at least three locations.

3) Fit side bearing shim of differential case and press in both side bearing inner races. Place differential case assembly into gear carrier using a rubber mallet. Align index marks on bearing cap and gear carrier, then install bearing cap on carrier.

4) As a second check, measure distance between bearing caps using a micrometer (see illustration). Specification obtained should be as indicated in table. Correct any deviation with the proper shim.

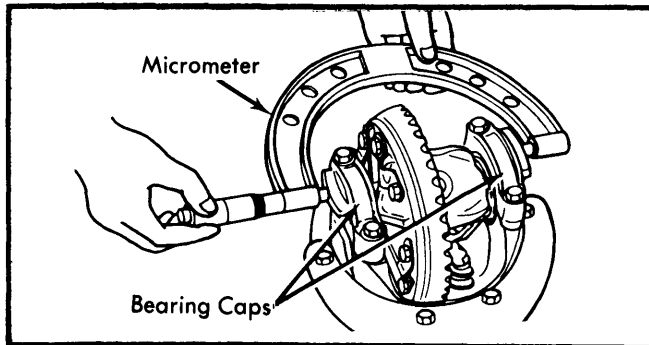

Fig. 7 Measuring Distance Between Bearing Caps

5) Using suitable dial indicator, measure ring gear-to-drive pinion backlash. Measurement should be as indicated in specifications. If backlash is less than specified, decrease thickness of left shim and increase right shim by same amount. If backlash is more than specified, reverse placement of shims in procedure above. Using same dial indicator check ring gear deflection, runout should be as specified.

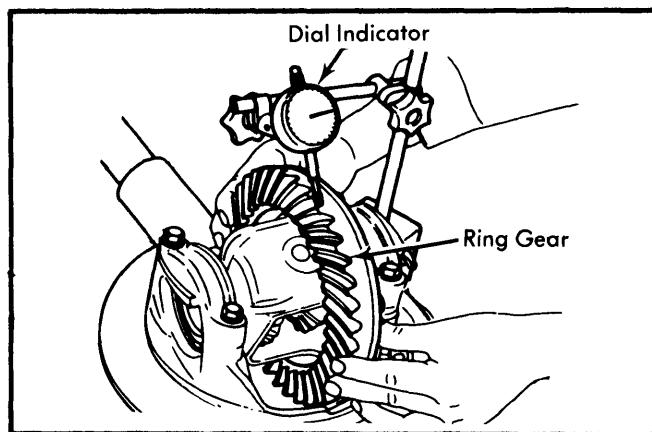

Fig. 8 Measuring Ring Gear Backlash

6) Check side bearing preload by measuring the amount of rotating torque needed to turn companion flange (see illustration). Check gear tooth contact pattern and correct any problem. **NOTE** - See Gear Tooth Contact Pattern at beginning of this section.

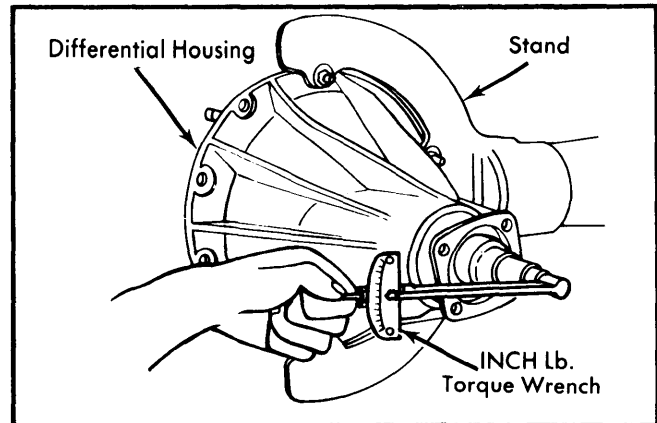

Fig. 9 Measuring Drive Pinion Preload

AXLE ASSEMBLY SPECIFICATIONS

Application	Specification
Drive Pinion Preload	
Without Oil Seal Installed	
810	6.1-13.0 INCH lbs. (7-15 cmkg)
620	8.7-11.3 INCH lbs. (10-13 cmkg)
With Oil Seal Installed	
200SX	6.1-8.7 INCH lbs. (7.0-10.0 cmkg)
B210	5-7 INCH lbs. (6-9 cmkg)
510	6.1-8.7 INCH lbs. (7.0-10.0 cmkg)
620	9.5-12.5 INCH lbs. (11-14 cmkg)
810	6.9-14 INCH lbs. (8-16 cmkg)
Ring Gear-to-Pinion Backlash	
200SX, B210 & 510	.004-.006" (.10-.15 mm)
810 & 620	.006-.008" (.15-.20 mm)
Standard Side Bearing Thickness	
200SX & 510	.7823" (18.5 mm)
B210	.6890" (17.5 mm)
620 & 810	.7874" (20 mm)
Distance Between Bearing Cap Edges	
B210	6.039-6.041" (153.40-153.45 mm)
200SX & 510	6.820-6.822" (173.23-173.29 mm)
810	7.811-7.817" (198.40-198.55 mm)
Pinion Gear-to-Side Gear Backlash	
All Models	.004-.008" (.10-.20 mm)

TIGHTENING SPECIFICATIONS

Application	Ft. Lbs. (mkg)
Drive Pinion Nut	
200SX, B210 & 510	101-217 (14-30)
All Others	101-123 (12-17)
Ring Gear Retaining Bolts	
B210	43-51 (6-7)
All Others	51-58 (7-8)
Side Bearing Cap Bolts	
620 & 810	28-36 (4-5)
All Others	36-43 (5-6)
Differential Carrier-to-Axle Housing	
B210, 200SX & 620	12-18 (1.7-2.5)
All Others	14-18 (2-2.5)
Companion Flange-to-Propeller Shaft	
All Models	17-24 (2.4-3.3)