

BMW INTEGRAL CARRIER

320i

DESCRIPTION

Final drive assembly has hypoid type ring and pinion gear and may have a multi-disc, self-locking differential (ZF DL-175). Housing has a removable rear cover. Differential carrier is retained in the sides of the housing by retaining plates and is supported by tapered roller bearings. Shims under the retaining plates maintain proper carrier bearing preload. Drive pinion gear is supported by roller bearings and preload is maintained by a collapsible spacer between the bearings.

AXLE RATIO & IDENTIFICATION

The ring and pinion gear set with Klingelnberg tooth design, can be identified by the letter "K" stamped on the head of the drive pinion gear; Gleason teeth are noted by an "H" or "F" stamping. Letter "S" indicates self-locking differential. To determine axle ratio, divide number of ring gear teeth by number of drive pinion gear teeth. The number of teeth on ring and drive pinion gears is stamped on forward left side of differential housing.

REMOVAL & INSTALLATION

Removal (Drive Shaft) — Rear drive shaft flange access is through a hole in the rear axle support. Detach from final drive by removing flange bolts.

Installation — To Install, reverse removal procedure.

Removal (Constant Velocity Joint) — Remove cover from joint housing, then remove snap ring from end of drive shaft. Remove clamps from boot then press drive shaft from joint. Remove dust boot.

Installation — To install, reverse removal procedure using sealer on boot-to-joint surfaces and install seal cover after packing joint with suitable grease.

AXLE SHAFTS & BEARINGS

Removal — Raise and support vehicle. Remove wheel, loosen castellated nut securing flange to axle shaft, then using a suitable puller, remove flange. Remove drive shaft, then using a soft headed mallet, drive axle shaft inward and out of housing. Drive out bearings and seals, then remove spacer sleeve and shim.

Installation — 1) To install, reverse removal procedure noting the following: Install inner bearing, then determine distance between outer races of inner and outer bearings.

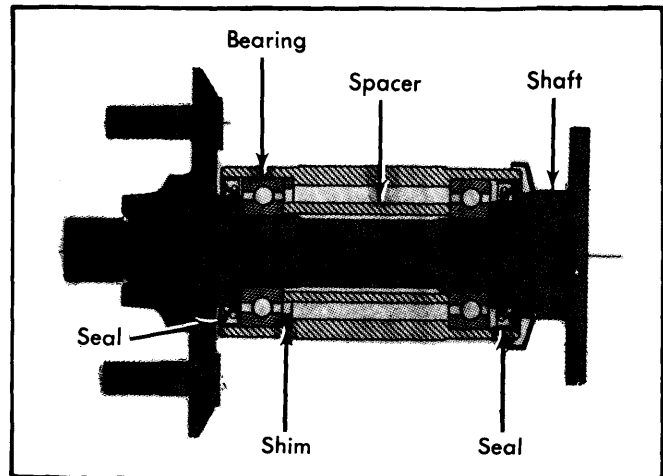

Fig. 2 Sectional View of Axle Shaft Assembly

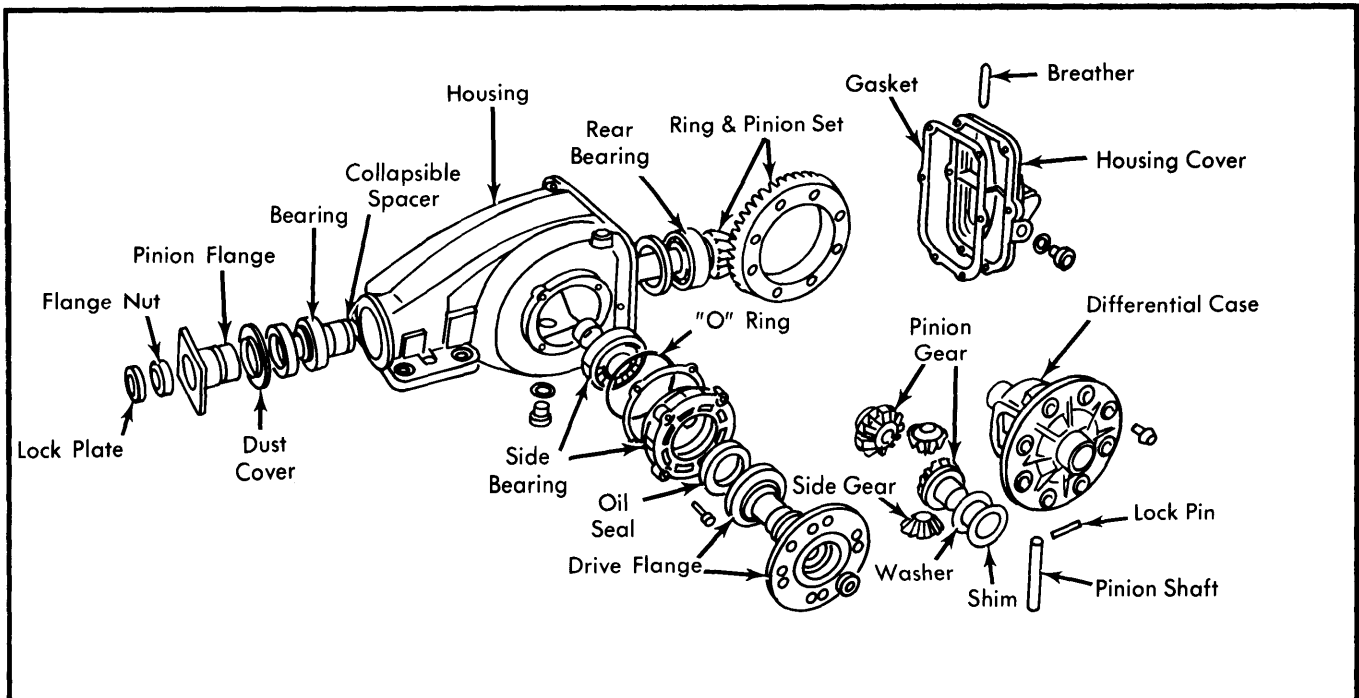

Fig. 1 Exploded View of BMW 320i Final Drive Assembly

BMW INTEGRAL CARRIER (Cont.)

2) Measure spacer and shim, then install spacer and a suitable shim that will obtain a wheel bearing play of .002-.004" (.05-.10 mm).

3) Pack bearings and hub with suitable grease, then using new seals, complete installation procedure.

DRIVE PINION COMPANION FLANGE OIL SEAL

Removal — Pull out shaft seal using special tool (00 5 000) used in conjunction with new special tools (00 5 006 and 33 1 309).

NOTE — Using the above tools eliminates complete disassembly of differential to replace seal.

Installation — Dip seal in gear lube and drive in seal against stop using special tools (33 1 170 and 00 5 500).

AXLE FLANGE & OIL SEAL

Removal — With final drive assembly mounted in special holder (33 1 040), remove cover. Remove bent circlips holding drive flange at pinion side gear. Pull out drive flange and remove shaft seal.

Installation — Fill groove between seal lips with grease and drive axle seal into position. Replace drive flange and circlips.

NOTE — Flanges with scored bearing or seal surfaces must be replaced.

DIFFERENTIAL ASSEMBLY

Removal — Detach propeller shaft and drive shafts from final drive. Suspend shafts out of way and detach self aligning support at final drive. Detach final drive at rear axle support and remove.

Installation — To install, reverse removal procedure ensuring that assembly is stress-free when tightened to specific torque.

OVERHAUL

DISASSEMBLY

Differential Housing — 1) Remove differential assembly as previously outlined, and mount assembly in suitable holding fixture. Drain oil and mark drive pinion shaft and companion flange for reassembly reference. Remove rear cover plate. Remove both axle flanges, as previously described, keeping right and left parts separated. Mark and remove carrier bearing retainer plates and shims. Remove carrier from housing.

2) Remove carrier bearings with suitable puller. Remove bolts securing ring gear to carrier then remove ring gear. Drive out pinion shaft lock pin. Remove pinion shaft and gears. Remove side gears with shims and thrust washers.

Drive Pinion Gear — 1) Remove differential carrier as previously outlined, then using an inch pound torque wrench, check preload on drive pinion gear. Hold companion flange

and remove retaining nut. Press drive pinion from flange and housing, then remove bearings.

2) Remove drive pinion shaft oil seal then extract pinion inner bearing race from case with special tool (33 1 350) and adapters. Note shim thickness under bearing race. Pull out front bearing race.

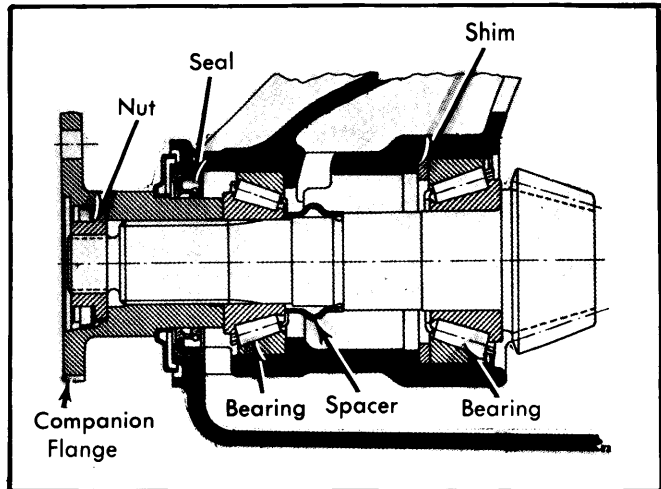

Fig. 3 Sectional View of Drive Pinion Gear Assembly

REASSEMBLY & ADJUSTMENT

Differential Assembly — Reverse disassembly procedure noting the following checks and adjustments.

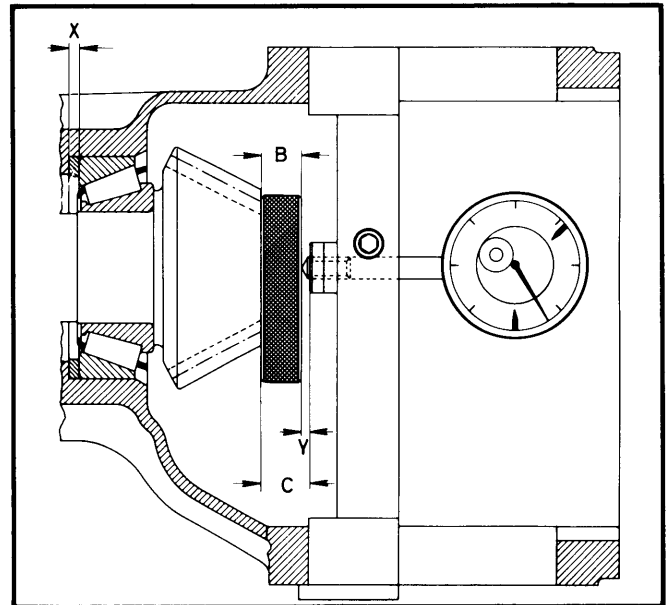

Fig. 4 Pinion Shim Measuring Points

Drive Pinion Bearing Preload — 1) If original ring and pinion gear set is being installed, install drive pinion gear using original shim and new collapsible spacer. If a new gear set is being installed determine correct size of shim to use in the following manner:

- Use special tool (33 1 381 with 33 1 382) and a dial indicator set at "0" with a preload of 0.157".

BMW INTEGRAL CARRIER (Cont.)

- Position tool (33 1 382) on drive pinion. Install tool (33 1 381) in case and note value of "Y".
- Basic adjustment "C" is 0.434" (11.02 mm). Master gauge "B" is 0.354" (9.00 mm).
- Place shims on "X" that correspond to the difference. Shims are available in 0.0004-0.0012" (0.01-0.03 mm).

2) Remove then reinstall drive pinion, bearings, and cones, as required, so new shim(s), collapsable spacer, and seal can be installed. Install companion flange and collared nut. Tighten nut to obtain specified pinion shaft bearing preload.

NOTE — If preload is exceeded, new collapsible spacer must be installed and procedure repeated.

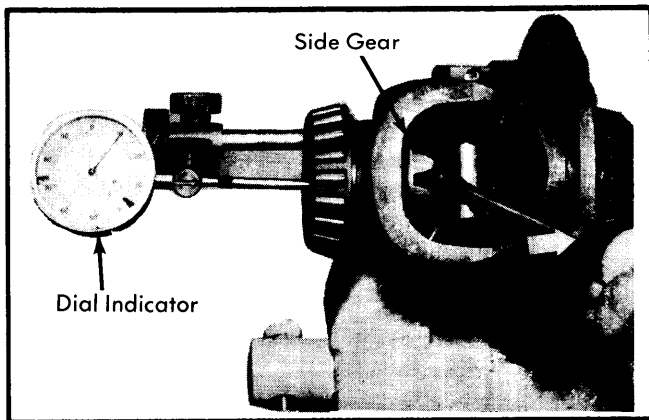

Fig. 5 Checking Side Gear-to-Pinion Gear Backlash

Side-to-Pinion Gear Backlash — With pinion gears and one side gear installed, mount dial indicator to carrier. Force side gear against case and zero the indicator, then force side gear against pinion gears. Value indicated is .002" (.05 mm) greater than desired thickness of shim and cup spring. Repeat procedure on opposite side gear.

Differential Bearing Preload — With differential carrier installed in housing without ring gear, and with carrier bear-

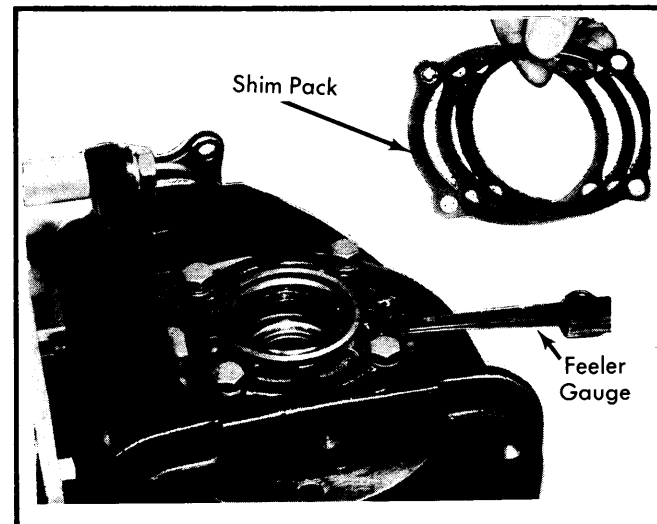

Fig. 6 Measuring for Differential Shim Pack Preload Requirements

ing retainer plates installed without shims, thread a bolt in against differential pinion gear shaft. Equally tighten retainer plate bolts until specified bearing preload is obtained. Using feeler gauge, check clearance between retainer plate and housing to determine required shim thickness. Take required shims and install them equally under both retainer plates.

Ring-to-Drive Pinion Gear Backlash — After establishing differential bearing preload, check ring-to-pinion gear tooth contact pattern. While maintaining established shim thickness, move shims from one retainer plate to the other, as necessary, to obtain proper contact pattern. After setting backlash, complete differential reassembly procedure.

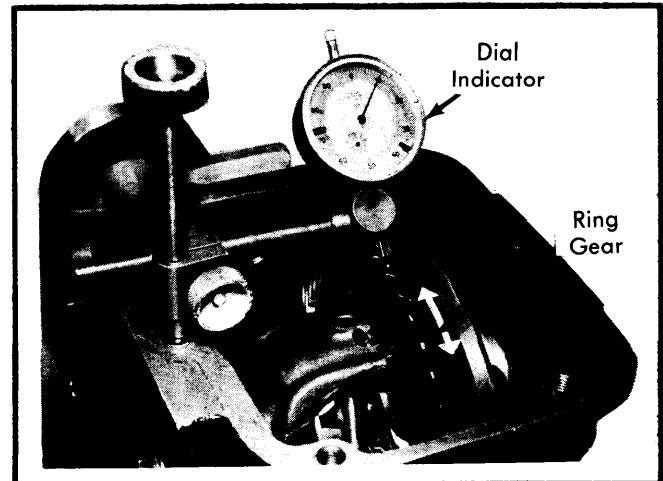

Fig. 7 Checking Ring Gear Backlash

AXLE ASSEMBLY SPECIFICATIONS

Application	Specification
Axle Shaft End Play002-.004" (.05-.10 mm)
Axle Drive Flange Runout (Max.).....	.006" (.15 mm)
Ring-to-Pinion Gear Backlash002-.004" (.06-.11 mm)
Drive Pinion Gear Bearing Preload	
With Oil Seal	27 INCH lbs. (32 cmkg)
Without Oil Seal	26 INCH lbs. (30 cmkg)
Differential Bearing Preload	
Without Oil Seal	18-24 INCH lbs. (20-28 cmkg)
With Oil Seal	34-38 INCH lbs. (39-45 cmkg)

TIGHTENING SPECIFICATIONS

Application	Ft. Lbs. (mkg)
Rear Housing Cover Bolts	32-35 (4.3-4.8)
Companion Flange Nut (Min.)	108 (15)
Carrier Bearing Retainer Plate Bolts	15-17 (2-2.4)
Drive Flange Nuts	24-27 (3.3-3.7)
Ring Gear-to-Carrier Bolts ^{①②}	63-74 (8.7-10.2)

① — Using Loctite.

② — Tighten evenly in criss-cross pattern.