

FIAT X1/9

X1/9

DESCRIPTION

Clutch is a dry, single plate, diaphragm spring type. Clutch actuation is hydraulic, using a firewall mounted master cylinder and a clutch housing mounted slave cylinder. A prelubricated clutch release bearing is also used.

REMOVAL & INSTALLATION

CLUTCH ASSEMBLY

Removal — 1) Disconnect positive battery cable. Remove air cleaner and carburetor duct cooling. From inside engine compartment, separate slave cylinder from transmission case. Install engine support. Remove upper transmission-to-crankcase mounting bolts.

2) Working from under the vehicle, disconnect and swing out-of-way shifting flexible link. Disconnect back-up lights and seat belt warning system wire. Remove starter. Disconnect and remove exhaust pipe.

3) Remove nuts from the hub end of half shaft. Remove attaching hardware mounting suspension control arm to supports. Free half shaft from hub end and fix other end to transmission to prevent premature disconnection.

4) Remove the following items: Flywheel cover, engine cross-member support, and lower engine-to-transmission bolts. Remove transmission/differential from below vehicle. Mark clutch position on flywheel and remove clutch.

Installation — To install, reverse removal procedure using suitable tool (A. 70210) to center clutch assembly.

CLUTCH MASTER CYLINDER

Removal — Steering column must be removed to gain access to clutch master cylinder. Disconnect and cap master cylinder hydraulic line. Remove two bolts attaching cylinder to support plate. Withdraw cylinder from actuating rod and remove from vehicle.

Installation — To install, reverse removal procedure and bleed hydraulic system.

CLUTCH SLAVE CYLINDER

Removal — Remove slave cylinder hydraulic hose and union. Disconnect cylinder push rod from clutch release bearing fork. Slightly compress return spring and remove two mounting bolts; slowly withdraw cylinder from support plate.

Installation — To install, reverse removal procedure ensuring slave cylinder snugly fits against support and that hydraulic system is bled.

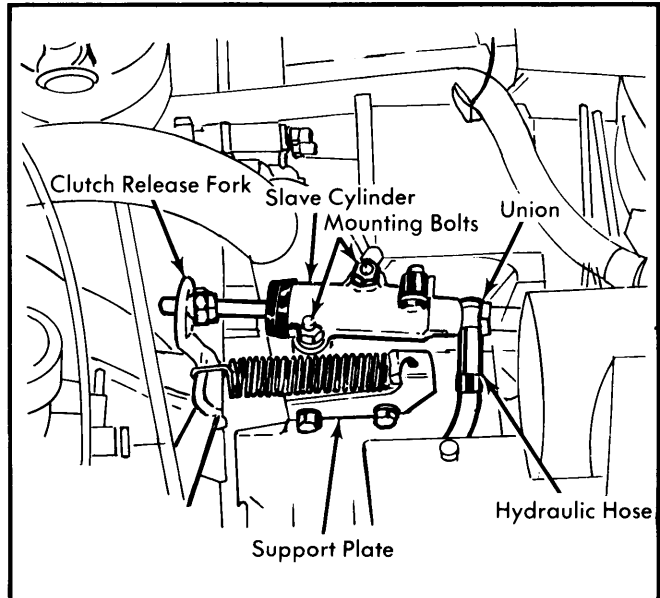

Fig. 1 Clutch Slave Cylinder Location

ADJUSTMENT

CLUTCH PEDAL HEIGHT & FREE PLAY ADJUSTMENT

1) Check clutch pedal travel, it should be approximately 6.7" (170 mm). If specification is not met, adjust screw on top of clutch pedal assembly until travel is correct. Turn screw out to reduce travel and in to increase it.

2) Check clutch pedal for approximately 1.25" (31.8 mm) free play. If specification is incorrect, adjust nut on slave cylinder until free play is to specification.

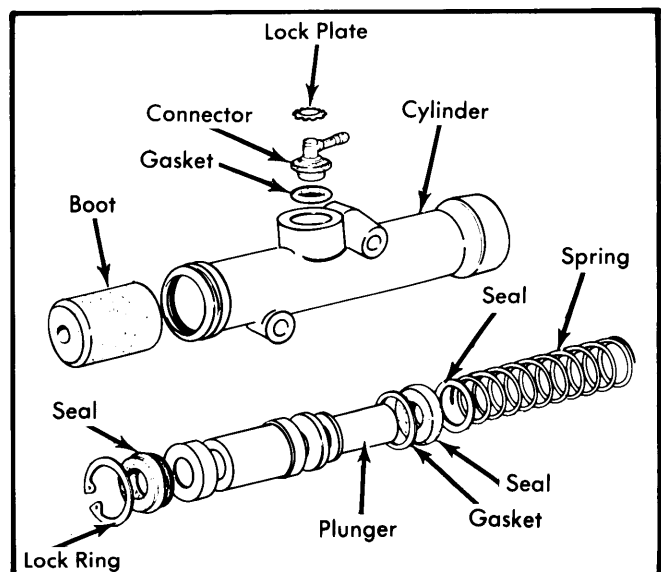

Fig. 2 Exploded View of Clutch Master Cylinder

Clutches

FIAT X1/9 (Cont.)

OVERHAUL

CLUTCH MASTER CYLINDER

Disassembly – Ease rubber dust boot back and remove snap ring, using long nosed pliers. Remove seal and complete plunger assembly. Pull out remaining gasket, seal and spring.

Reassembly – Lightly coat all components with brake fluid. Insert spring and seal into position. Fit piston assembly and seal, then install snap ring. Slip boot over cylinder housing.

CLUTCH SLAVE CYLINDER

Disassembly – Pull push rod from slave cylinder. Slide dust boot off housing. Remove lock ring, washer, and spring, then shake out piston assembly. Seal at rear of cylinder bore may not come out with piston assembly.

Reassembly – Lightly coat all components with brake fluid before reassembly. Insert rear seal, and piston assembly. Refit spring, washer, and lock ring. Install dust boot and push rod.

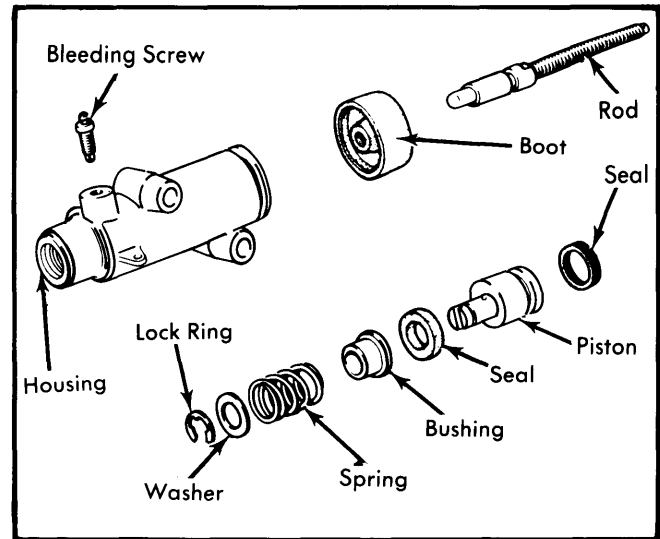

Fig. 3 Exploded View of Clutch Slave Cylinder

TIGHTENING SPECIFICATIONS

Application	Ft. Lbs. (mkg)
Clutch Flywheel Bolts	10.8 (1.5)
Clutch Release Fork Bolt.....	18 (2.5)
Slave Cylinder Piston Adjusting Nut.....	18 (2.5)
Slave Cylinder Support Plate-to- Transmission Case	18 (2.5)
Support Plate-to-Transmission Case Stud Nut	18 (2.5)