

## BMW

320i  
530i  
633CSi  
733i

## DESCRIPTION

BMW clutch system consists of the following major components:

- Dry, single plate disc
- Diaphragm spring pressure plate
- Pre-lubricated clutch release bearing with release lever

Clutch is hydraulically operated. Clutch master cylinder is mounted to fire wall and provides hydraulic fluid to slave cylinder. Slave cylinder is mounted off the clutch housing. Release portion of system is self-adjusting. Pedal travel is the only adjustment that may have to be made.

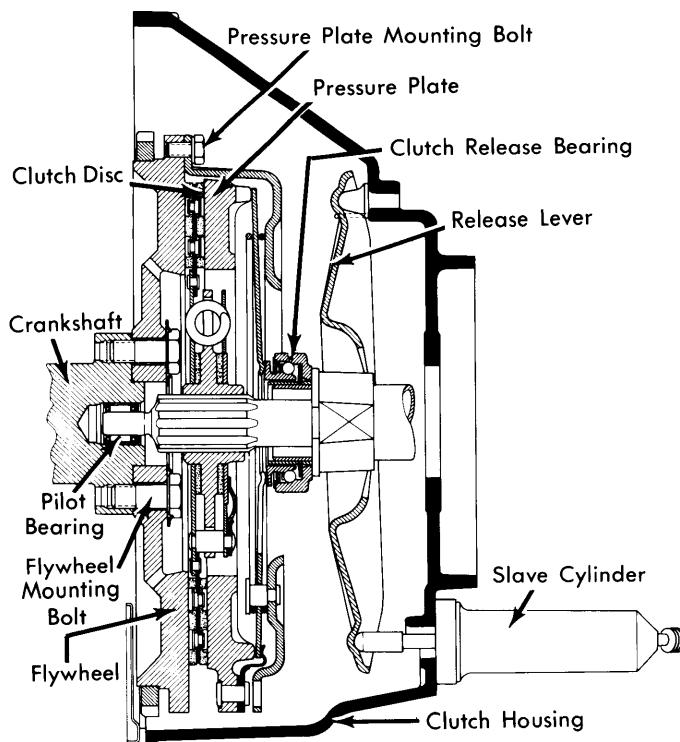

**Fig. 1 Sectional View of Clutch Assembly for Part Identification and Component Relationship (633 CSi Shown – All Models Similar)**

## REMOVAL &amp; INSTALLATION

## CLUTCH ASSEMBLY

**Removal, 320i** – 1) Remove console.

2) Disengage circlip, remove washer, and pull out gear shift selector rod. Gear shift lever will remain in vehicle.

3) Remove all upper clutch housing mounting bolts.

4) Remove exhaust pipe support bracket. Separate exhaust pipe at manifold.

**NOTE** – A special clamp tool designed to hold Giubo coupling while mounting nuts and bolts are being removed has been released. Special tool number is 26 1 012.

5) Remove bolts mounting propeller shaft to transmission.

**NOTE** – Coupling remains on propeller shaft.

6) Remove heat shield. Separate center support bearing. Maneuver propeller shaft downward and pull it from center support journal. Place shaft out of way.

7) Disconnect speedometer cable.

8) Disconnect back-up light wires. Separate wiring harness from mounting clips.

9) Remove 2 clutch slave cylinder bolts and hydraulic line mounting bracket (located on clutch housing).

10) Remove flywheel inspection cover.

11) Place support under engine and an adjustable jack under transmission.

12) Unbolt remaining clutch housing bolts. Slide transmission rearward until free.

13) Retain flywheel. Loosen clutch assembly mounting bolts alternately and evenly. Remove clutch assembly.

**Installation** – Make the following notes during installation:

- Slide clutch disc into place. Fit pressure plate over flywheel dowels.
- Center the clutch assembly with alignment tool 21 2 100 (or equivalent).
- Tighten mounting bolts evenly.
- Make sure exhaust pipe support bracket is loose when pipe-to-manifold nuts are tightened.
- Preload center bearing on propeller shaft by moving bracket .078" (2 mm) forward. Slots are provided for adjustment.
- Slave cylinder bleed screw must face down.

**Removal, Except 320i** – 1) From under vehicle, remove circlip and washer from selector rod. Disengage rod from control arm. From inside vehicle, force up shifter dust boot and remove retainer circlip. Pull up on gear shift lever to remove.

2) Remove any exhaust system parts that may interfere with transmission removal.

**NOTE** – A special clamp tool designed to hold Giubo coupling while mounting nuts and bolts are being removed has been released. Special tool number is 26 1 012.

3) Separate propeller shaft from transmission.

**NOTE** – Special propeller shaft coupler remains on propeller shaft.

4) Remove heat shield. On 733i models only, remove crossbracket that runs under propeller shaft and attaches to underbody with 4 bolts.

5) Remove center support bearing.

6) Maneuver propeller shaft out of center bearing housing and place out of way.

7) Support engine. Place an adjustable jack under transmission.

## BMW (Cont.)

- 8) Disconnect speedometer from transmission.
- 9) Remove 2 crossmember-to-body nuts and bolts. Slightly lower transmission.
- 10) Separate clip on clutch housing. Clip is bolted to driver's side.
- 11) Remove slave cylinder. Hydraulic line does not have to be disconnected.
- 12) Disconnect brake back-up light wires.
- 13) Remove bolts holding transmission to clutch housing. Slide transmission back until clear, then remove from vehicle.
- 14) Remove clutch housing mounting bolts. Take off flywheel inspection cover. Slide clutch housing off.
- 15) Retain flywheel from rotating. Loosen pressure plate mounting bolts alternately and evenly. Slide out clutch assembly.

**Installation** — Note the following when reinstalling transmission and clutch assembly:

- Place pressure plate over dowels. Center entire clutch assembly on flywheel using tool 21 2 100 (or equivalent).
- Temporarily fit slave cylinder. Face cylinder face down.
- Align release lever and slave cylinder.
- Fill lubricating groove in release bearing with Molykote BR 2-750 (or equivalent).
- Make sure transmission is in gear before inserting into clutch assembly.
- Carefully slide transmission guide sleeve into release bearing and clutch assembly.
- Rotate output flange until input shaft is fitted into clutch.
- Remove slave cylinder.
- Tighten transmission mounting bolts.
- Tighten from nut side when installing propeller shaft.
- Preload center bearing by sliding bracket .078" (2 mm) forward. Adjustment slots are provided.

### RELEASE BEARING & RELEASE BEARING LEVER

- Removal** — 1) Remove transmission.
- 2) On 320i models, remove clutch housing.
  - 3) Remove spring clip from mounting holes in clutch housing.
  - 4) Slide off release lever and separate lever from bearing.

**Inspection** — Measure bearing at points shown in Fig. 2. If bearing is not within specifications it should be replaced.

**Installation** — To install, reverse removal procedure.

### CLUTCH MASTER CYLINDER

**Removal** — 1) Remove trim from under left side of instrument panel.

**NOTE** — On 733i models only, it is necessary to detach windshield wiper fluid reservoir for access.

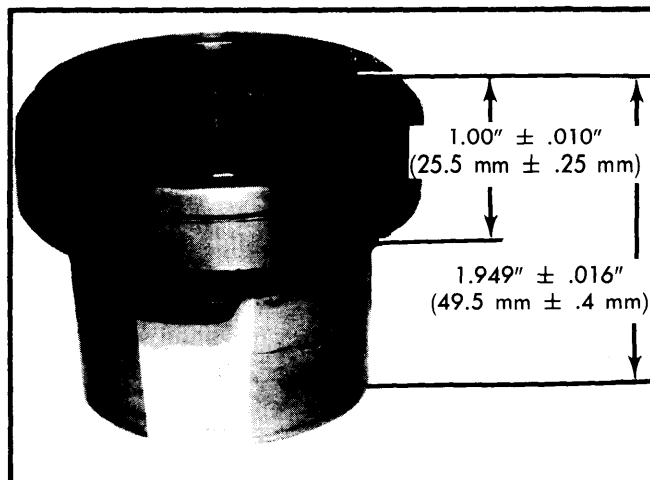

**Fig. 2 Make Measurements Shown to Determine Serviceability of Clutch Release Bearing**

- 2) Remove bolt and separate master cylinder push rod from pedal. On 733i models only, once master cylinder push rod is released, pedal spring may become dislodged.
- 3) Siphon off most of hydraulic fluid from master cylinder reservoir.
- 4) Separate reservoir line.
- 5) Separate slave cylinder line.
- 6) Remove mounting bolts. Pull master cylinder forward and out of vehicle.

**Installation** — To install, reverse removal procedure. Bleed hydraulic system. Make sure 733i pedal spring is engaged in guide before piston rod is attached.

### CLUTCH SLAVE CYLINDER

- Removal** — 1) Siphon off as much hydraulic fluid as possible.
- 2) Remove slave cylinder mounting bolts located on clutch housing.
  - 3) Once slave cylinder is pulled back, disconnect hydraulic line.

**Installation** — Reverse removal procedure and note:

- Bleed screw faces DOWN.
- Push rod must be coated with Molykote 2 (or equivalent).
- Bleed hydraulic system.

## OVERHAUL

### CLUTCH MASTER CYLINDER

- Disassembly** — 1) Remove push rod, if necessary.
- 2) Side back dust boot.
  - 3) Remove circlip.
  - 4) Extract internal components.

# Clutches

## BMW (Cont.)

**Cleaning & Inspection** – 1) Clean all internal components with alcohol.

2) If master cylinder bore is badly scored or has excessive corrosion, replace cylinder.

**Reassembly** – 1) Replace following parts with new ones provided in overhaul kit:

- Cap
- Circlip
- Seals
- Seal Plug
- Plain Washer
- Dust Boot

2) Insert master cylinder push rod and adjust length to approximately 5.5" (140 mm). See Fig. 3.

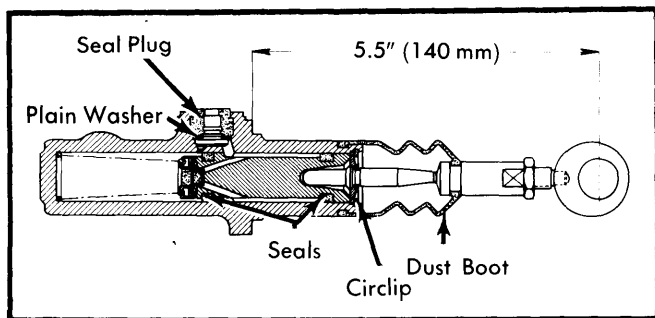

**Fig. 3 Sectional View of Clutch Master Cylinder**

### CLUTCH SLAVE CYLINDER

**Disassembly** – 1) Remove push rod.

2) Remove retainer ring.

3) Tip slave cylinder in a manner that will allow internal components to fall out.

**Cleaning & Inspection** – 1) Clean all internal components with alcohol.

2) If slave cylinder bore is badly scored or has excessive corrosion, replace cylinder.

**Reassembly** – Replace following parts with new ones provided in overhaul kit:

- Retainer ring
- Dust Cap
- Sleeve

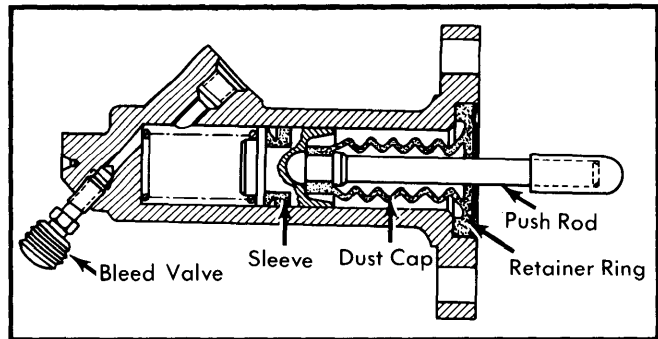

**Fig. 4 Sectional View of Clutch Slave Cylinder ADJUSTMENT**

**320i & 530i Only** – Adjust pedal at master cylinder push rod. Vary rod length by loosening lock nut and turning rod in or out to obtain a total pedal travel of approximately 6.1" (155 mm).

### HYDRAULIC BLEEDING

1) Fill fluid reservoir.

2) Attach bleeder hose to slave cylinder bleed screw. Submerge the free end of hose into a container part full with brake fluid.

3) Pump clutch pedal about 10 times. Hold pedal down on last pump stroke.

4) Loosen bleed screw and allow air to escape.

5) Close bleed screw.

6) Repeat steps 3-5 until all air is bled from clutch hydraulic system.

### TIGHTENING SPECIFICATIONS

Application	Ft. Lbs. (mkg)
Clutch-to-Flywheel .....	16-17 (2.2-2.4)
Master Cylinder Mounting Bolt	
Except 733i .....	16-17 (2.2-2.4)
Except 530i and 733i .....	18-20 (2.5-2.8)
Clutch Housing-to-Engine	
530i	
8 mm Bolts .....	16-17 (2.2-2.4)
10 mm Bolts .....	31-35 (4.3-4.8)
320i, 633CSi, 733i	
8 mm Bolts .....	18-19 (2.5-2.7)
10 mm Bolts .....	34-37 (4.7-5.1)
Transmission-to-Clutch Housing	
633CSi .....	52-57 (7.2-8.0)
733i .....	54-59 (7.5-8.2)