

4.5 LITER V8

ENGINE CODING

ENGINE IDENTIFICATION

Dual overhead camshaft V8 engine is coded M 28. Engine code and identification number is stamped on the front reinforcing rib in the top half of the crankcase.

ENGINE & CYLINDER HEADS

ENGINE

Removal – 1) With car standing on all 4 wheels, loosen engine compartment cross braces. Disconnect battery ground cable at spare wheel well. Detach windshield washer hoses and engine compartment light wires. Remove engine hood. Remove cap from coolant expansion tank. Remove air intake hoses and entire air cleaner assembly.

2) Raise car on hoist at specified pick up points. Place wooden block between central tube and rear tunnel brace. Detach splash shield at bottom and drain radiator. Remove left and right water drain plugs from crankcase. Drain engine oil and remove lower body brace. Disconnect exhaust pipes at manifolds and remove left and right heat shields. Detach ground cable at body. Install and tighten drain plugs.

3) Unscrew clutch slave cylinder at clutch housing and remove with line connected. Remove mounting strap for pressure line to slave cylinder. Disconnect wires at starter and remove clutch housing with starter.

4) Disconnect clutch lever by pressing down in direction of clutch. Release starter wire from clamps on steering cross member. Remove socket head bolts and push drive shaft coupling back on drive shaft. Unscrew throwout bearing sleeve mounting bolts and push sleeve toward flywheel.

5) Detach left and right engine shock absorbers at control arms, then at upper mountings. Disconnect air conditioner temperature switch wires on radiator and compressor clutch at connector plug. Loosen compressor and remove from console but do not disconnect hoses. Suspend compressor with wire.

6) Remove air pump filter housing and alternator cooling hose. Remove lower fan shroud. Disconnect all coolant hoses and bottom oil hose at radiator. Remove engine mounts separately by lifting with hydraulic jack and wooden block on oil pan. Lower engine to front cross member carefully. Move jack and pad to second side and remove mount in same manner.

7) Remove clutch/engine mounting bolts and lower car. Remove remaining coolant/heater hoses between engine and radiator/chassis. Disconnect upper oil hose at radiator. Remove radiator mounting bolts and lift out radiator. Disconnect engine wire harness and distributor wire transmitter plugs. Disconnect B+ wire and remove control unit. Detach and place ignition coil aside.

8) Disconnect fuel feed and return lines. Detach power steering pump lines at pump and supply tank. Drain oil and remove tank. Disconnect brake booster vacuum hose at manifold. Disconnect accelerator and cruise control cable, remove holder and clamp and place cables outside. Cover A/C condenser with a thin board to prevent damage when removing engine.

9) With engine adapter (9137) in eyelets provided, lift until snug with car resting on its wheels. Remove upper engine block/clutch housing mounting bolts. Pull engine forward carefully and remove short drive shaft with guide tube. Lift engine out of car.

Installation – To install, reverse removal procedures noting that heater lever should be in "warm" position when filling cooling system. Coolant level must reach center of expansion tank with engine warm.

CYLINDER HEADS

NOTE – Manufacturer does not furnish removal and replacement procedures for cylinder heads. Heads may be removed with engine in vehicle. Following items must be noted when performing cylinder head operations:

1) Allow engine to cool prior to draining coolant. Heads must not be removed while engine is still hot. Remove camshaft housing, then loosen cylinder head nuts in reverse of tightening sequence.

2) Left and right cylinder head gaskets are different. Arrow must face forward and word "TOP/OBEN" must face up. Tighten head in 3 steps according to the sequence shown in Fig. 1. Tighten to final torque and allow to stand at least 30 minutes. Loosen nuts by 1/4 turn, then tighten to final torque of 61 ft. lbs. (8.5 mkg).

3) Flat gasket between cylinder head and camshaft housing must be placed properly to ensure that oil supply bore to camshaft is not blocked. Camshaft housing must be completely assembled prior to installation. Housing is located on heads with 2 dowel pins and mounted with Allen head bolts.

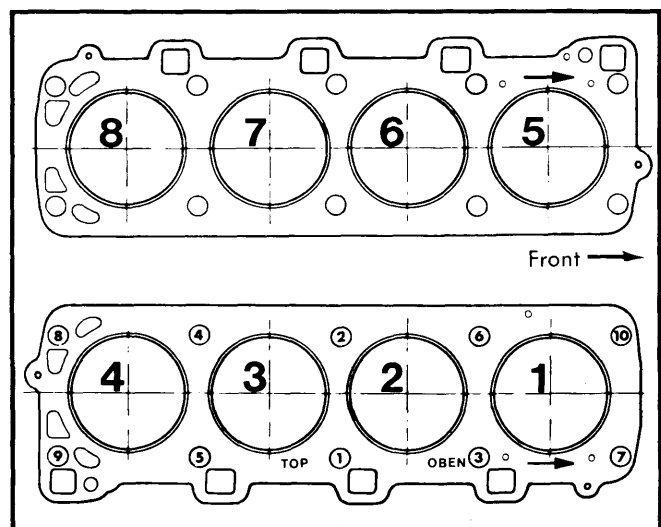

Fig. 1 Cylinder Head Tightening Sequence (Loosen in Reverse Order)

VALVES

VALVE ARRANGEMENT

Valves are arranged in-line with the larger, intake valve at the front of each cylinder.

4.5 LITER V8 (Cont.)

HYDRAULIC VALVE LIFTERS

Bucket type hydraulic lifters operate in sintered metal sleeves. Cam lobes depress the lifters which are filled with engine oil under pressure through internal passages. With hydraulic lifters, no further valve clearance adjustment is necessary.

NOTE — Use caution that lifters and sleeves are installed in original positions. Do NOT mix up lifters and sleeves.

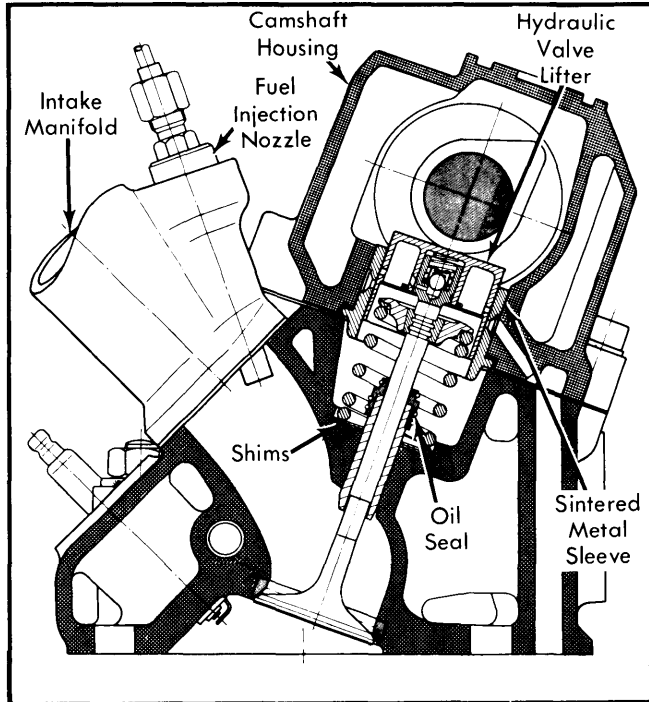

Fig. 2 Cross Sectional View of Cylinder Head with Valve Lifter and Camshaft

VALVE SPRINGS

Valve springs may be removed using conventional overhead valve type compressor. Remove keepers and lift off retainer and spring. To install, reverse removal procedures.

CAUTION — Note number of shims between valve spring and cylinder head and replace in same position.

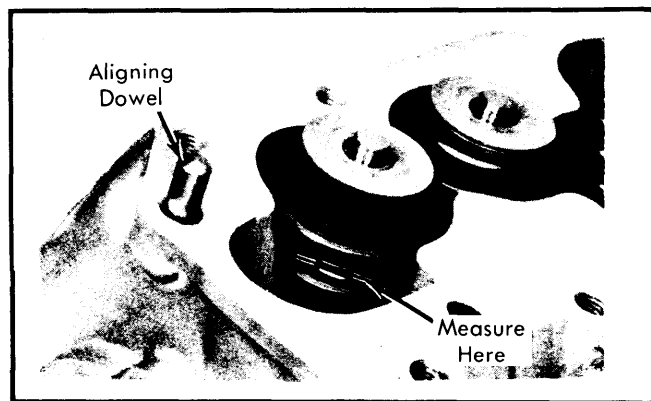

Fig. 3 Measuring Installed Valve Spring Length

VALVE SPRING INSTALLED LENGTH

To check valve spring installed length, install tool (9138) with shims for applicable valve, spring retainer and keepers. Read distance from tool and correct, if required, by adding or removing shims. Correct intake spring length is 1.544+ .020" (39.6+.5 mm) and exhaust length should be 1.505+.020" (38.6+.5 mm).

VALVE STEM OIL SEALS

With valve springs removed, pry off old seal using caution to prevent marring guide. Place plastic sleeve on valve stem, lubricate seal and push into place using "mushroom" type installing tool.

PISTONS, PINS & RINGS

OIL PAN

Oil pan is of cast aluminum design with ribs for reinforcing and cooling. Pan attaches to lower crankcase section with gasket and cap screws. Manufacturer does not provide specific removal and replacement instructions.

PISTONS

Pistons and bore diameters come in 3 tolerance groups. Piston crown is stamped "0", "1" or "2" to correspond with similar marking stamped on cylinder block.

Tolerance Group	Cylinder Bore In. (mm)	Piston Diameter ^① In. (mm)
0	3.7050 (95.000)	3.7036 (94.964)
1	3.7054 (95.010)	3.7040 (94.974)
2	3.7058 (95.020)	3.7044 (94.984)

① — ±.0003" (.007 mm).

Piston pin bore is offset from center of piston by .0058" (1.5 mm). Depressions for valves are cast into piston crown at an angle of 20°. Piston and rod must be properly assembled and installed with valve pockets facing EXHAUST manifold.

CRANKSHAFT MAIN & CONNECTING ROD BEARINGS

CRANKCASE LOWER SECTION

Crankcase lower section provides saddles for main bearings. When replacing, it is not necessary to remove old sealant. Clean grease from surfaces and apply Loctite 573 (green) with a short-pile roller. Install lower section and tighten mounting bolts by hand. Install oil pump, then tighten lower section mounting nuts to final torque in sequence illustrated.

MAIN & CONNECTING ROD BEARINGS

Use Plastigage method to determine main and connecting rod bearing clearance. Check crankshaft end play using dial indicator. Main bearing radial wear limit is .0062" (.16 mm) and end play limit is .0156" (.40 mm). Connecting rod bearing wear limit is .0039" (.10 mm). Ensure that connecting rods are installed to piston correctly. With piston indentations facing

4.5 LITER V8 (Cont.)

away from centerline (down), small chamfer on rod faces rod on same journal. Larger chamfer faces web of crankshaft.

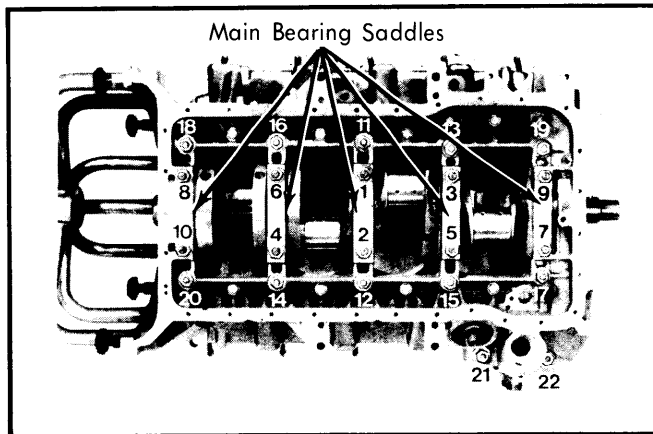

Fig. 4 Crankcase Lower Section Tightening Sequence

CRANKSHAFT OIL SEALS

Crankshaft oil seals are installed with crankcase lower half removed. Use tool (9126) to align flywheel end seal, and tool (9125) to install pulley end oil seal.

CAMSHAFT

TIMING BELT

Toothed timing belt drives camshafts, distributor, oil pump and water pump. As the engine assembly heats and cools, belt tension varies, so a multiple disc belt tensioner is installed to compensate for these changes. To adjust tension, remove right hand camshaft drive belt upper cover. Turn engine in normal direction through two revolutions and check belt for damage or wear. Continue turning until TDC mark on crankshaft and camshaft align with markers. Using tester (9138), check belt tightness between tension roller and camshaft sprocket. Set adjustment screw on tensioner as required and recheck tension.

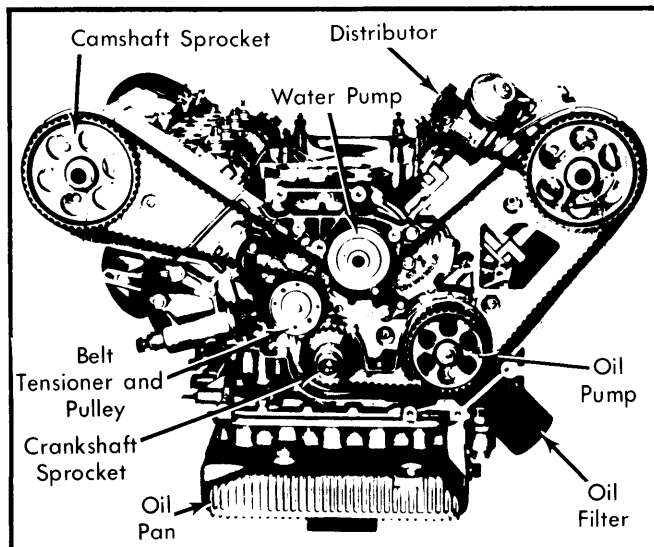

Fig. 5 Front View of Engine with Belt Covers Removed

CAMSHAFT TIMING ADJUSTMENT

With timing belt and tensioner removed, turn both camshafts until notches in drive sprockets align with marks on camshaft housings. Rotate crankshaft so that TDC mark on vibration damper aligns with indicator. Install belt and tensioner. Rotate crankshaft and recheck tension as in previous step.

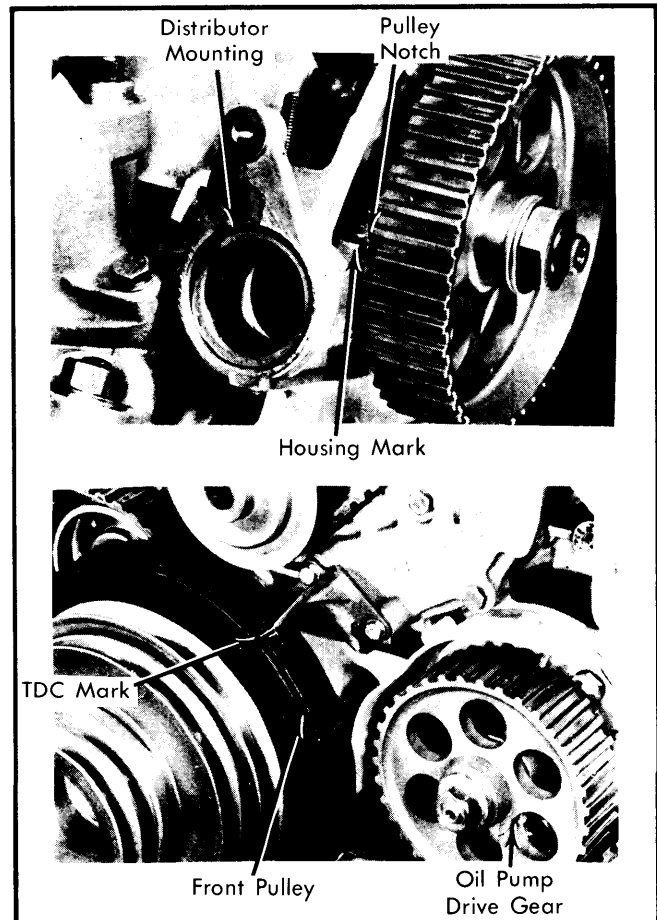

Fig. 6 View of Left Camshaft Sprocket and Front Pulley with Timing Marks Aligned

DRIVE BELT TENSIONER

Tensioner consists of 8 packets of 5 bimetal discs stacked alternately. If service is required, remove housing from engine and disassemble, noting that housing contains transmission fluid. Clean and reassemble, ensuring that packs of 5 discs are installed alternately. Fill housing $\frac{1}{3}$ full with SAE 90 transmission fluid. Slide in piston assembly and install circlip. Add transmission oil, if necessary, until oil level reaches circlip. Replace dust cover, clamp and pressure rod. Install on engine.

CAMSHAFTS

Camshafts run in 5 bearings without shells in camshaft housing. Housing cover plates must be removed in order to remove rubber plugs covering top row of bolts. Camshaft housing assembly must be completely assembled before installation. Housing is located on heads with 2 dowel pins and mounted with Allen head bolts.

4.5 LITER V8 (Cont.)

ENGINE OILING

ENGINE OILING SYSTEM

Engine utilizes a wet sump with an oil cooler integrated in the car radiator as a heat exchanger. Sickle type oil pump is located in a separate cast iron housing bolted to the left front of the engine. Pump is driven by toothed belt. Full pressure system pumps oil to pressure relief valve, thermostat, main oil passage, filter, crankcase upper section, cylinder heads and camshaft housings. All main oil passages are cast into the mating surface of the crankcase lower section.

Oil Filter — Full-flow spin-on type oil filter is easily changed from beneath left side of car.

Normal Oil Pressure — 72 psi at 5000 RPM, 178°F (80°C).

Crankcase Capacity — Approximately 8.5 quarts, with filter change.

ENGINE COOLING

928 utilizes an aluminum radiator and a mechanically driven visco-fan. Water pump is driven by the back side of the toothed timing belt. An expansion tank with filler opening and water level sending unit is mounted at the right rear of the engine compartment. Water level is indicated on the instrument cluster.

Cooling System Capacity — 17 quarts.

Thermostat — Begins to open at 180°F (83°C).

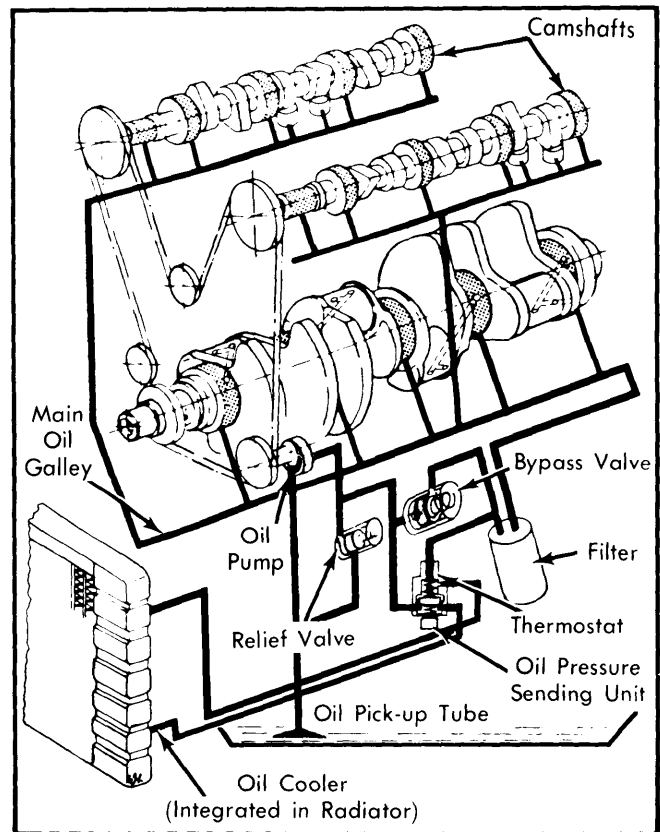

Fig. 7 Porsche 928 Engine Lubrication System

ENGINE SPECIFICATIONS

GENERAL SPECIFICATIONS										
Year	Displ.		Carburetor	HP at RPM	Torque (Ft. Lbs. at RPM)	Compr. Ratio	Bore		Stroke	
	cu. ins.	cc					in.	mm	in.	mm
1978	273	4474	Fuel Inj.	219@5250	245@3600	8.5:1	3.74	95.0	3.11	78.9

VALVES							
Engine & Valve	Head Diam. In. (mm)	Face Angle	Seat Angle	Seat Width In. (mm)	Stem Diameter In. (mm)	Stem Clearance In. (mm)	Valve Lift In. (mm)
4474 cc Intake	1.677 (43)	45°	45°3498 (8.97)
Exhaust	1.482 (38)	45°	45°3490 (8.95)

4.5 LITER V8 (Cont.) ENGINE SPECIFICATIONS (Cont.)

PISTONS, PINS, RINGS						
Engine	PISTONS	PINS		RINGS		
	Clearance In. (mm)	Piston Fit In. (mm)	Rod Fit In. (mm)	Rings	End Gap In. (mm)	Side Clearance In. (mm)
4474 cc	.0014 (.036)	Interference	Interference

CRANKSHAFT MAIN & CONNECTING ROD BEARINGS							
Engine	MAIN BEARINGS				CONNECTING ROD BEARINGS		
	Journal Diam. In. (mm)	Clearance In. (mm)	Thrust Bearing	Crankshaft End Play In. (mm)	Journal Diam. In. (mm)	Clearance In. (mm)	Side Play In. (mm)
4474 cc	2.730 (70.0)	.0008-.0038 (.070-.098)	No. 3	.0042-.0121 (.110-.312)	2.028 (52.0)	.0008-.0027 (.02-.07)

VALVE TIMING				
Engine	INTAKE		EXHAUST	
	Open (ATDC)	Close (ALDC)	Open (BLDC)	Close (BTDC)
4474 cc	8°	55°	38°	2°

TIGHTENING SPECIFICATIONS

Application	Ft. Lbs. (mkg)
Cylinder Head Bolts	
Step 1	14 (2.0)
Step 2	36 (5.0)
Step 3⓪	61 (8.5)
Main Bearing Carrier	
Step 1	14 (2.0)
Step 2	29 (4.0)
Step 3	
10 mm	38-41 (5.2-5.7)
12 mm	43-47 (6.0-6.5)
Connecting Rod Nuts	42-46 (5.8-6.3)
Camshaft Housing	33 (4.5)
Flywheel	69-73 (9.5-10.0)
Front Pulley	181-188 (25.0-26.0)
Camshaft Pulley	29-33 (4.0-4.5)
Oil Pump	
Step 1	11 (1.5)
Step 2	14-16 (2.0-2.2)
Spark Plugs	18-25 (2.5-3.5)

⓪ — Allow to stand for 30 min. after setting Step 3 torque, then loosen ¼ turn each. Retighten to 61 ft. lbs. (8.5 mkg).