

XJS & XJ12 SERIES 2 V12

ENGINE CODING

ENGINE IDENTIFICATION

Engine number is stamped on cylinder block at rear of engine, between cylinder heads.

ENGINE, CYLINDER HEAD & MANIFOLDS

ENGINE

NOTE — It is necessary to remove entire power unit (engine and transmission assembly) as an assembly. Engine and transmission may then be separated.

1) Remove hood, lower grill and battery. Depressurize fuel system. Drain engine and cooling system.

NOTE — Only qualified air conditioning personnel should loosen or remove air conditioning hoses or fittings to prevent personal injury. All hoses or fittings which are removed should be immediately sealed with clean dry plugs.

2) On air conditioned models, discharge air conditioning system. Disconnect suction and pressure hoses. Remove pressure and suction unions from rear of compressor and plug openings. Tie hoses back away from engine.

3) Remove fender well straps and air cleaners. Disconnect oil pump-to-cooler lines and remove radiator complete with oil cooler.

4) On air conditioned models, remove compressor delivery hose from vehicle. Tie condenser/evaporator hose back away from engine.

5) Disconnect coolant hoses to remote header tank at engine. Remove nut and lock washer attaching engine mount to engine bracket. Remove oil from power steering reservoir. Disconnect lines from power steering pump.

6) Disconnect connectors from alternator and separate engine harness connector. Remove hose between servo unit and vacuum reservoir. Disconnect clips securing fuel pipes to filter, plug pipes.

7) Disconnect operating line from heater vacuum reservoir non-return valve at manifold stub and heater water valve at valve inlet. Disconnect heater return line from water rail at firewall union. Remove coil and ballast resistor assembly.

8) Disconnect clips securing cold start relay harness from left hand fuel rail and cross over pipe. Remove remaining clips on harness. Remove cover of cold start relay, disconnect cables. Remove harness from engine.

9) Disconnect cable from throttle switch and trigger unit. Remove connectors from kickdown switch. Remove starter cable from firewall terminal.

10) Install suitable engine support tool (MS.53A) into drip channel directly above rear lifting eyes and tighten supporting screws. Disconnect both exhaust pipes at manifolds. Remove front exhaust pipe which is not trapped by steering pinion housing. Lower trapped front pipe and move rear end of pipe toward center line of vehicle. Slide pipe towards front of vehicle and draw flanges down past steering housing.

11) Remove attaching hardware from heat shields. Remove four screws, washers and spacers from engine mounting plate. Place a jack and suitably formed block of wood beneath mounting plate and remove nut attaching rear engine mount.

12) Lower jack and remove mounting plate. Disconnect propeller shaft and speedometer cable. Remove pinch bolt attaching transmission outer selector cable and disconnect inner cable from selector lever at transmission by removing nut and lock washer.

13) Remove ground strap from frame member. Place a jack beneath front suspension crossmember and remove engine support tool. Attach suitable lifting sling to engine eyes.

NOTE — Chains of engine hoist must be of sufficient length to ensure that distance between lifting eyes and hook of hoist is 34.5" (876 mm) from front eyes to hook and 41" (1041 mm) from rear eyes to hook.

14) Carefully lift engine with hoist, simultaneously raising jack to keep engine level. Lift only 2-3" (51-76 mm).

CAUTION — Throughout lift, rear of engine must be kept as high as possible until oil pan is clear of steering housing.

15) Lift engine level, while observing forward corner of oil pan and steering housing. Apply side pressure to engine until it has been lifted clear of steering assembly and lines. Pull engine from subframe, allowing angle of tilt to increase until drive flange is clear of firewall. Lift engine to clear bumper.

INTAKE MANIFOLDS (LEFT & RIGHT)

1) Remove air cleaner and drain cooling system. Depressurize fuel system (remove connector from fuel pump relay switch, crank engine for a few seconds). Remove fuel pipe from overrun valves. Remove hose clip securing pressure regulator return hose from fuel rail.

2) Disconnect manifold pressure hose and electrical connectors from kickdown switch. Disconnect throttle cable from pedestal. Release throttle cross-rod from bell-crank. Disconnect electrical connectors from injectors and cold start injector. Disconnect brake vacuum hose.

3) Remove nuts securing manifold to cylinder head. Remove screws securing air rail clips to manifold ram tubes. Remove EGR valve from throttle housing flange. Remove manifold stud spacers. Remove intake manifold, carefully moving air balance pipe and fuel pipes out of the way. Plug intake ports.

CYLINDER HEAD

NOTE — The following procedure may be used for removal of either right or left cylinder head.

Removal — 1) Disconnect battery and drain cooling system. Remove right camshaft cover (required when either right or left cylinder head is removed). Remove rubber grommet from front of timing cover.

XJS & XJ12 SERIES 2 V12 (Cont.)

2) Rotate crankshaft until valve timing gauge (C.3993) can be fitted in slot in camshaft front flange. Insert blade of release tool through timing cover grommet hole and release locking catch on timing chain tensioner. Using suitable tool (JD.50), retract timing chain tensioner.

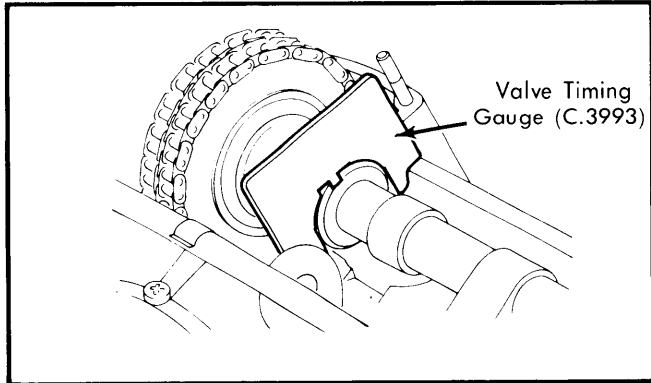

Fig. 1 Valve Timing Gauge in Position for Timing Chain Removal or Installation

3) If left cylinder head is to be removed, remove left camshaft cover. Disconnect camshaft sprocket from camshaft and attach a suitable retaining tool (Special Tool JD.40).

4) Remove heat shield from exhaust manifold and solenoid heat shield (right-hand head). Loosen screw clamp attaching heater return pipe-to-hose and ease cross pipe forward. Remove clamps attaching manifold coolant bleed pipe to front of cylinder head.

5) Remove camshaft oil feed banjo nut. Remove three nuts holding front of cylinder head to timing cover. Progressively loosen cylinder head nuts working from center outward. Remove cylinder head and place on wood blocks to prevent damage to valves. Discard old gasket.

NOTE — Do not rotate engine until suitable cylinder liner retaining tools (Special Tool JD.41) have been attached to cylinder head studs.

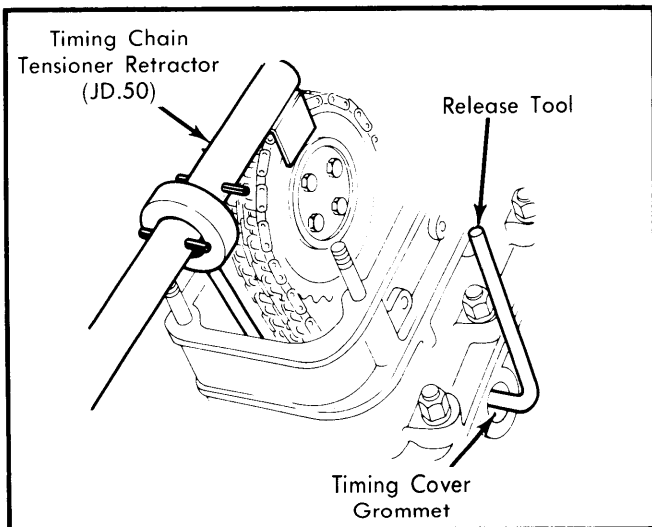

Fig. 2 Retracting Timing Chain Tensioner

Installation — 1) Attach dial indicator to a cylinder head stud and rotate crankshaft to set No. 1 piston on right bank at TDC. Turn camshaft until valve timing gauge (C.3993) can be attached to slot in camshaft front flange. Repeat for camshaft on left cylinder head. Remove cylinder liner retaining tool.

NOTE — Do not rotate crankshaft until cylinder head(s) are installed.

2) Install gasket making sure side marked "TOP" is up. Do not use jointing compound or grease. Install right cylinder head and nuts. Tighten nuts to specifications in order shown in illustration.

3) Tighten cylinder head-to-timing cover nuts to specifications. If camshaft and sprocket holes are not in alignment, remove circlip which holds camshaft coupling to sprocket and disengage coupling from splines.

4) Rotate coupling until access to retaining bolt holes can be obtained. Remove sprocket retaining tool (JD.40) and bolt coupling to camshaft.

5) Engage sprocket with coupling, then replace circlip and remove valve timing gauge (C.3993). Repeat procedures as outlined in steps 2) through 6) for left cylinder head.

6) Rotate engine until remaining camshaft sprocket retaining bolts can be installed; secure bolts with tab washers. Remove timing chain tensioner retracting tool (Special Tool JD.42 and Support Plate JD.42-1).

7) Insert blade of release tool through hole in timing cover and trip locking catch. Reinstall rubber grommet. Install exhaust pipes and camshaft covers. Refill cooling system and connect battery.

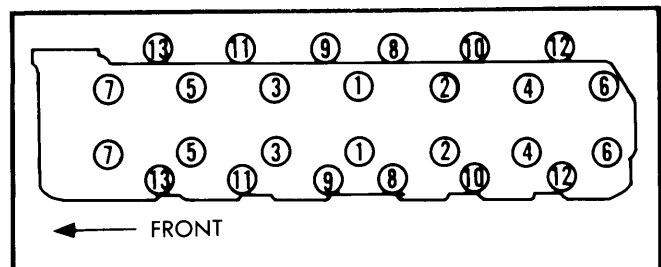

Fig. 3 Cylinder Head Tightening Sequence

VALVES

VALVE ARRANGMENT

Right Side — E-I-I-E-E-I-I-E-E-I-I-E (front to rear).

Left Side — E-I-I-E-E-I-I-E-E-I-I-E (front to rear).

VALVE GUIDE SERVICING

1) With valves and valve springs removed, check clearance between valve guide and stem. Clearance should be to specification.

XJS & XJ12 SERIES 2 V12 (Cont.)

2) To replace guides, immerse head in boiling water for 30 minutes. Using piloted drift, drive guide out of head from combustion chamber side. Coat new guide with graphite grease and attach circlip.

3) Heat cylinder head once again and drive guide in from top until circlip is seated in groove.

Replacement Guides

Application	Marking	Size In. (mm)
1st Oversize	2 Grooves506-.507 (12.85-12.88)
2nd Oversize	3 Grooves511-.512 (12.98-13.00)

4) When new guides are installed, always use next size larger than old guide. Ream guides to obtain proper valve stem clearance.

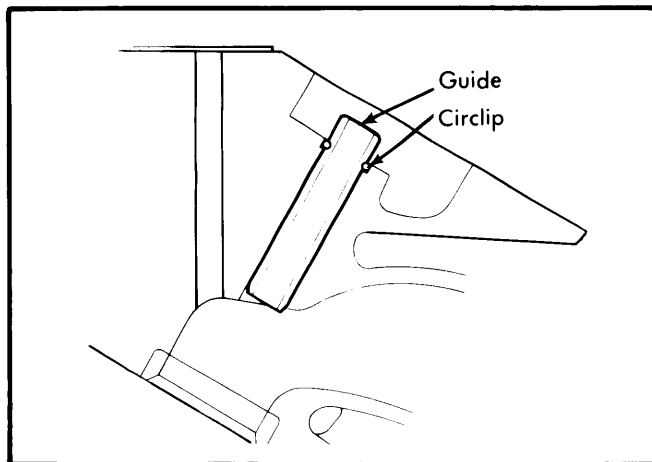

Fig. 4 View Showing Correct Valve Guide Installation

VALVE STEM OIL SEALS

Install valves and place cylinder head on wooden blocks. Install valve spring seats, intake valve oil seals, springs and collars. Compress springs using suitable tool (Special Tool J.6118B and Adaptor J.6118C-2) and install keepers.

NOTE — Oil seals used on intake valves only.

VALVE TAPPET CLEARANCE ADJUSTMENT

1) With intake manifolds and camshaft covers removed, check clearance between each tappet and heel of each cam. Record clearance for each and then subtract appropriate valve clearance from clearances obtained. Select suitable adjusting pads which equal this new measurement. Corrected clearance should be .012-.014" (.305-.356 mm) with engine cold.

2) To install new adjusting pads, proceed as follows to remove camshaft and tappets: Bend back locking tabs and remove two camshaft sprocket retaining bolts. Rotate engine until access to remaining bolts is obtained. Bend back locking tabs, mark position of camshaft to sprocket, and remove bolts.

3) Using suitable tool (Jaguar Sprocket Retaining Tool JD.40), hold sprocket in place. Lift camshaft out of tappet block. Remove tappets and install adjusting pads.

NOTE — Do not rotate engine with camshaft disconnected.

4) Reinstall tappets, camshaft, bearing caps, washers and nuts. Tighten bearing cap nuts evenly and torque to 9 ft. lbs. Recheck clearance, reassemble, replace camshaft cover and manifolds.

NOTE — Adjusting pads are available in .001" (.03 mm) increment sizes from .085-.110" (2.16-2.79 mm). Pads have a letter stamped on surface which indicates size: "A" through "Z" respectively.

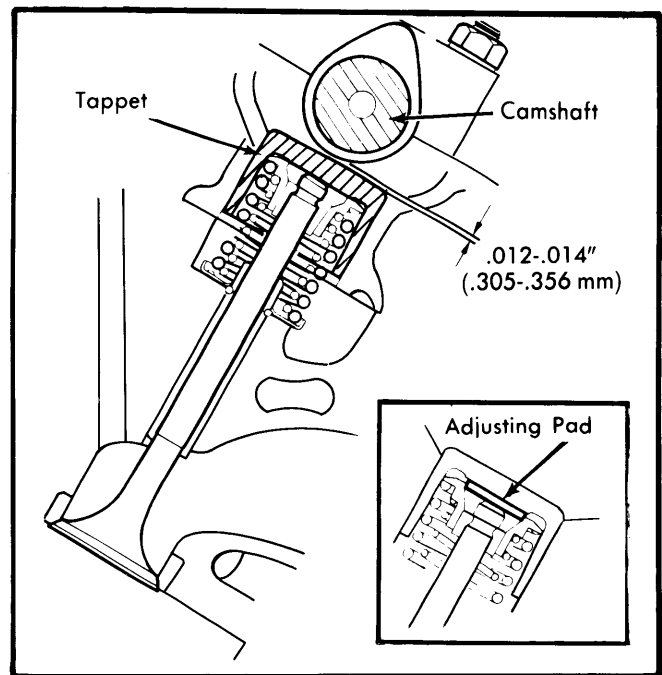

Fig. 5 Correct Valve Tappet Clearance Adjustment Procedure

PISTONS, PINS & RINGS

OIL PAN REMOVAL

NOTE — Complete oil pan removal is best accomplished with engine out of vehicle. Lower oil sump pan removal and replacement procedures follow.

To remove oil sump pan, drain engine oil and remove pan retaining screws. Remove sump pan and clean gasket surfaces. Coat new gasket lightly with suitable sealant and replace pan. Due to the different lengths of pan retaining screws, it is essential that they be replaced in their proper location.

XJS & XJ12 SERIES 2 V12 (Cont.)

PISTON & ROD REMOVAL & INSTALLATION

1) With cylinder head and oil pan removed, remove crankcase baffle plate. Remove nuts, bearing cap and bearing. Push connecting rod up cylinder bore, remove piston together with connecting rod.

NOTE — Cylinder liner retaining tools (JD.41) must be installed prior to disassembly or any movement of engine parts due to wet liner type cylinder sleeve.

2) Coat all parts with engine oil and make sure that piston ring gaps are evenly spaced around circumference of piston. Place piston into bore with word "FRONT" facing forward and chamber on rod big-end facing crank pin radius. Push piston and rod assembly down into bore, locate bearings, install bearing caps and nuts and tighten to specifications.

PISTON PIN REPLACEMENT

NOTE — Pistons are supplied complete with pin. As pins and pistons are matched assemblies, it is not permissible to interchange component parts.

Remove circlip, push pin out of piston. When installing pin, piston should be fitted so the word FRONT faces towards front of engine.

FITTING PISTONS

No oversize pistons are available due to use of wet liner type cylinder sleeves. If liner or piston is damaged or worn, replacement must be of standard size.

NOTE — Bearings are available in only standard size. Due to extremely hard surface of crankshaft journals, it is not possible to grind crankshafts satisfactory. Crankshafts are available on exchange basis and are supplied complete with matching bearings.

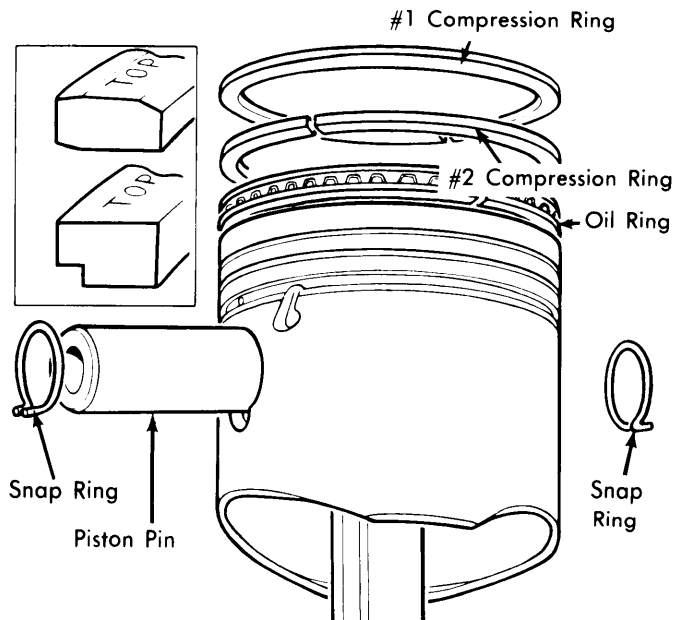

Fig. 6 Exploded View of Piston Assembly

CRANKSHAFT MAIN & CONNECTING ROD BEARINGS

MAIN BEARING SERVICE

NOTE — While it is possible to replace main bearing shells with engine in vehicle, this should only be accomplished when it is certain that crankshaft is not damaged.

1) With engine out of vehicle and piston and rod assemblies removed, remove drive plate from crankshaft. Timing cover must be removed and timing chain disengaged from sprocket. Remove oil pump assembly.

2) Remove small nuts from main bearing caps, starting from center bearing. Remove pillar nuts and large nuts from caps in same sequence. Remove bearing caps and shells. Lift crankshaft from block and remove upper half of main bearing shells.

3) Ensure that all components are scrupulously clean and replace all seals. Oil bearing shells liberally and place upper halves in block. Replace crankshaft and lower bearing caps with shells. Beginning at center, tighten bearing caps one at a time to specified torque.

CYLINDER LINER REPLACEMENT

NOTE — If liners are to be replaced after removal, they should be marked and reinstalled in their original bore.

1) With crankshaft and pistons removed, remove cylinder liner retaining tools (Special Tools JD.41). Position a suitable mandrel between cylinder liner and arbor press.

2) Press out cylinder liners from below. To install, smear liners with Hylomar and slip liners into cylinder block. Remove excessive sealant. Make sure liners are correctly seated and install retaining tools.

NOTE — If cylinder liners are replaced. New liners must be of the same grade as the old liners.

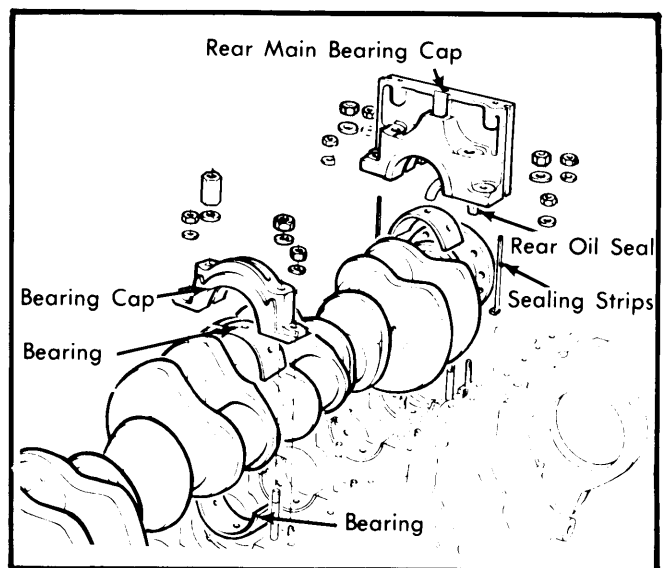

Fig. 7 Exploded View of Main Bearing & Rear Oil Seal Assemblies

XJS & XJ12 SERIES 2 V12 (Cont.)

Cylinder Liners

Bore Grade	In. (mm)
A-Red	3.543 (89.98)
B-Green	3.544 (90.01)

REAR MAIN BEARING OIL SEAL SERVICE

1) With crankshaft out of cylinder block and rear main bearing casting removed, install new sealing strips in grooves of rear main bearing casting. Install new rear oil seal. Install bearing casting on cylinder block and tighten nuts. Seat rear oil seal using suitable tool (Special Tool JD.17B & Adaptor JD.17B-1). Remove rear main bearing casting.

2) Coat upper main bearings with oil and install in cylinder block. Smear rear oil seal with Dag Colloidal Graphite. Oil upper main bearings and install in cylinder block, position crankshaft, install bearings in caps and install caps. Tighten to specifications.

THRUST WASHER ALIGNMENT

Measure crankshaft end play. Remove bearing caps and install thrust washer(s) in groove in block; select washers as necessary to bring end play within specifications. Grooved side of washer must face outward.

ENGINE FRONT COVER & OIL SEAL

1) Drain cooling system and remove front sub-frame crossmember complete with expansion tank. Remove both cylinder heads and oil pan. Remove alternator and power steering pump. Remove air injection pump and water pump.

2) Remove bolts holding pulley to damper and remove pulley. Remove crankshaft damper bolt and strike damper sharply with leather mallet. Remove damper and cone.

3) Pry seal out of timing cover and discard. Remove spacer. Smear new oil seal with engine oil and install oil seal in recess. Tap into place using leather mallet. Reinstall spacer and reverse removal procedure.

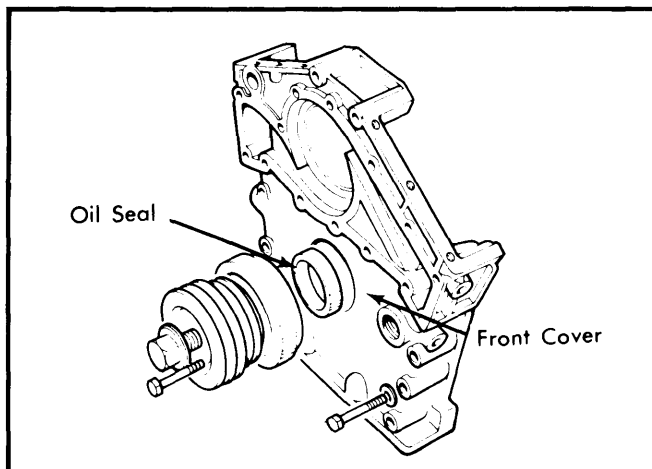

Fig. 8 Detail of Front Cover Oil Seal

4) If entire front cover is to be removed, remove alternator and air pump mounting brackets and remove bolt and serrated washers which hold timing cover to cylinder block. Note positions of bolts and dowel bolts. Remove timing cover.

NOTE — If entire front cover is removed, oil seal may be replaced with front cover removed from engine.

CAMSHAFT

CAMSHAFT REMOVAL

1) With camshaft covers removed, bend back locking tabs and remove two camshaft sprocket retaining bolts. Rotate engine until valve timing gauge can be installed in slot in camshaft. Bend back locking tabs and mark relative position of camshaft to sprocket.

2) Remove bolts. Attach sprocket retaining tool (Special Tool JD.40). Do not rotate engine with camshaft disconnected. Progressively loosen camshaft bearing caps nuts starting with center cap and working towards ends. Remove bearing caps, lift camshaft out of tappet block.

TIMING CHAIN REMOVAL

With timing cover removed, install suitable tool to retain intermediate shaft (jackshaft). Retaining tool (Special Tool JD.39) available for this purpose. Disconnect timing chain from camshaft and intermediate shaft (jackshaft) sprockets. Remove crankshaft sprocket and chain.

NOTE — Do not rotate engine with chain removed.

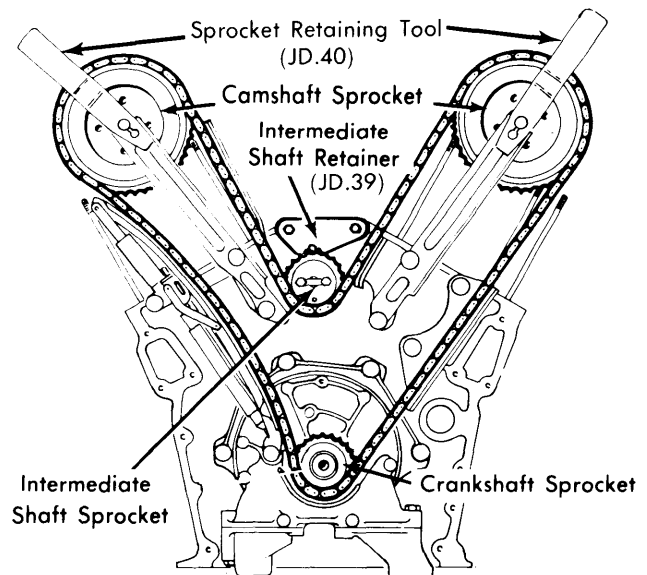

Fig. 9 View of Timing Chain Installation

ENGINE OILING

Crankcase Capacity — 12 quarts (includes filter).

Oil Filter — Full-flow, replaceable element.

Jaguar Engines

XJS & XJ12 SERIES 2 V12 (Cont.)

OIL PUMP

Pump is of "Epicyclic" type with internal and external gears and crescent type cut off. Drive gear is concentric around crankshaft nose.

Removal - Remove timing cover and timing chain tensioner. Remove spacer from crankshaft and remove timing chain and sprocket from crankshaft. Remove Woodruff key. To install, reverse removal procedure.

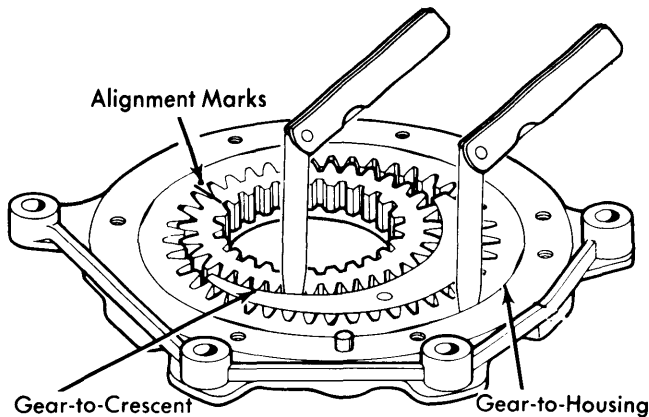

Fig. 10 Correct Procedure to Measure Oil Pump Clearances

Overhaul - 1) Remove eight bolts and lockwashers and remove pump cover from gear housing. Mark drive and driven gear faces to make sure gears are replaced in same position as removed.

2) Remove both gears, and clean thoroughly. Check condition of all gears. Remove burrs with file. Reinstall driven gear and check radial clearance between gear and housing. Checks should not be taken at any of the six radial flats on the gear.

3) Reinstall drive gear and check radial clearance between gear and crescent. Check gear end play by placing straight edge across joint face of housing and measure clearance between straight edge and gear.

4) To reassemble, lubricate all gears with clean oil, check that surfaces are clean, and reverse disassembly procedure.

Oil Pump Specifications

Application	Clearance ① In. (mm)
Driven Gear-to-Housing005 (.127)
Drive Gear-to-Crescent006 (.152)
Gear End Play005 (.127)

① - Specifications given are maximum allowable.

ENGINE COOLING

WATER PUMP REMOVAL

NOTE - Water pump is sealed unit and no overhaul is possible. Exchange pumps do not come with pulley, therefore pulley must be removed before sending in defective pump. Pulley must then be installed on pump before placing on engine.

1) Drain and remove radiator. Remove lower cowl and mounting bracket and lay aside. Remove fan and fan drive unit. Remove fan belt.

2) Remove trunnion adjusting bolt and hardware attaching idler pulley housing. Unscrew two studs. Remove air pump and compressor pump belts.

3) Loosen steering pump pivot bolts enough to draw adjustment bolt from special stud. Remove special stud. Remove thermostat housing and bottom hose complete as an assembly. Remove crankshaft pulley and damper assembly.

NOTE - Tap damper with a rawhide mallet to break taper. Do not mislay Woodruff key.

4) Loosen upper hose clamp on engine cross pipe. Remove screw and washers attaching water pump. Pull pump out and downwards to clear cross pipe hose. To install, reverse removal procedure.

Thermostats - Two thermostats are used. Opening temperature is 174-181F (79-83C).

Cooling System Capacity - 22 quarts.
Radiator Cap - 13 psi.

ENGINE SPECIFICATIONS

GENERAL SPECIFICATIONS										
Year	Displ.		Carburetor	HP at RPM	Torque (Ft. Lbs. at RPM)	Compr. Ratio	Bore		Stroke	
	cu. ins.	cc					in.	mm	in.	mm
1978	326	5343	Fuel Inj.	244 @ 5250	269 @ 4500	7.8:1	3.543	90	2.756	70

Jaguar Engines

5-129

XJS & XJ12 SERIES 2 V12 (Cont.)

ENGINE SPECIFICATIONS (Cont.)

VALVES							
Engine & Valve	Head Diam. In. (mm)	Face Angle	Seat Angle	Seat Width In. (mm)	Stem Diameter In. (mm)	Stem Clearance In. (mm)	Valve Lift In. (mm)
V12 Intake	① 1.623-1.627 (41.22-41.32)	45°	44.5°3092-.3093 (7.854-7.856)	.001-.004 (.03-.10)	.375 (9.5)
V12 Exhaust	① 1.358-1.362 (34.50-34.60)	45°	44.5°3092-.3093 (7.854-7.856)	.001-.004 (.03-.10)	.375 (9.5)

① — XJ-S models; Intake 1.620-1.630" (41.15-41.40 mm), Exhaust 1.355-1.365" (34.42-34.67 mm).

VALVE SPRINGS			
Engine	Free Length In. (mm)	PRESSURE Lbs. @ In. (kg @ mm)	
		Valve Closed	Valve Open
V12 Inner	1.734 (44)
V12 Outer	2.103 (53.4)

PISTONS, PINS, RINGS						
Engine	PISTONS	PINS		RINGS		
	Clearance In. (mm)	Piston Fit In. (mm)	Rod Fit In. (mm)	Rings	End Gap In. (mm)	Side Clearance In. (mm)
V12	.0012-.0017 (.03-.04)	Push Fit	.0000-.0002 (.000-.005)	1	.014-.020 (.36-.51)	.0029 (.07)
				2	.010-.015 (.25-.38)	.0034 (.09)
				Oil	.015-.045 (.38-1.14)	① .0055-.0065 (.14-.17)

① — XJ-S models have a self expanding oil ring.

CRANKSHAFT MAIN & CONNECTING ROD BEARINGS							
Engine	MAIN BEARINGS				CONNECTING ROD BEARINGS		
	Journal Diam. In. (mm)	Clearance In. (mm)	Thrust Bearing	Crankshaft End Play In. (mm)	Journal Diam. In. (mm)	Clearance In. (mm)	Side Play In. (mm)
V12	3.0007-3.0012 (76.218-76.231)	.0015-.003 (.04-.07)	Center	.004-.006 (.10-.15)	2.2994-2.3000 (58.40-58.42)	.0015-.003 (.04-.07)	.007-.013 (.17-.33)

Jaguar Engines

XJS & XJ 12 SERIES 2 V12 (Cont.)

ENGINE SPECIFICATIONS (Cont.)

CAMSHAFT			
Engine	Journal Diam. In. (mm)	Clearance In. (mm)	Lobe Lift In. (mm)
V12	1.0615-1.0620 (26.96-26.97)	.001-.003 (.03-.07)

VALVE TIMING				
Engine	INTAKE		EXHAUST	
	Open (BTDC)	Close (ABDC)	Open (BBDC)	Close (ATDC)
V12	17°	59°	59°	17°

TIGHTENING SPECIFICATIONS

Application	Ft. Lbs. (mkg)
Cylinder Head	
1/16" Nuts	52 (7.2)
3/8" Nuts	27-28 (3.7-3.9)
Main Bearing Cap	
1/2" Nuts	63 (8.7)
3/8" Nuts	27-28 (3.7-3.9)
Connecting Rod Caps	40-41 (5.5-5.7)
Flywheel	67 (9.3)
Crankshaft Bolt	125-150 (17.3-20.7)
Camshaft Cap Nuts	9 (1.2)
Camshaft Cover Screws	8 (1.1)
Union Block-to-Compressor	10-25 (1.4-3.5)