

Fiat Engines

124 & 131 4 CYLINDER

ENGINE CODING

ENGINE IDENTIFICATION

Engine identification number is stamped in pad above oil filter mount on left side of engine.

Application	Engine Code
124 Spider & 131 Models with Catalytic Converter	132 A1.031.6
124 Spider & 131 Models without Catalytic Converter	132 A1.040.6

ENGINE & CYLINDER HEAD

ENGINE

Removal – 1) Remove hood and air cleaner. Loosen fuel tank cap to relieve pressure. Disconnect battery. Mark for identification and disconnect vacuum and fuel lines and electrical leads. Disconnect accelerator and remove linkage from cam housing cover.

NOTE – On A/C equipped cars, it will be necessary to discharge system and remove condenser and fan assembly prior to removal of engine. When installing, system will require evacuation and charging.

2) Drain cooling system and disconnect hoses. Disconnect automatic transmission cooling lines (if equipped). Remove radiator and cooling fan assembly.

3) Disconnect remaining hoses and wires from chassis to engine at engine. Disconnect exhaust pipe at manifold. Disconnect A/T fluid dipstick from support bracket (if equipped).

4) From underneath vehicle, remove oil filter, engine splash pans and any remaining electrical connections. Remove starter by passing through oil filter opening. (On A/C equipped vehicles, pull starter from mounted position and tie to engine until engine is removed.) Remove speedometer cable support bracket from engine mount.

5) Remove fuel inlet line from pump. Remove nuts and washers holding engine mount isolators to crossmembers, and ground strap to engine mount. Install transmission support and remove bolts securing transmission to engine. If A/T equipped, remove bolts attaching flywheel to torque converter.

6) Attach engine sling and hoist engine until mount clears cross members. Move engine forward until clear and lift from engine compartment.

Installation – To install, reverse removal procedure. Ensure that pilot shaft engages clutch properly (manual transmission).

CYLINDER HEAD

Removal – 1) Disconnect battery, drain cooling system and remove air cleaner. Disconnect water temperature sending unit connection and spark plug wires. Disconnect water hoses.

2) Remove timing belt cover and oil dipstick tube. Rotate crankshaft by hand until timing marks on rear of camshaft

sprockets align with pointers on cam housing. Remove timing belt. See *Timing Belt Replacement*. From engine left side, remove vacuum and fuel lines and electrical connections.

3) Disconnect accelerator rod from carburetor, then remove linkage from cam housing cover. Disconnect exhaust pipe from manifold. Disconnect transmission fluid dipstick from support bracket (A/T only). Remove cylinder head bolts and lift off head with gasket.

Installation – 1) Before installation of cylinder head, position camshafts so that reference marks on sprockets are aligned with fixed pointers on front of cylinder head.

2) When installing cylinder head, camshafts must not be moved in either direction. Rotate crankshaft and bring pistons number 1 and 4 to TDC.

3) Install two dummy studs in one cylinder head bolt hole at front and rear of engine. Install new cylinder head gasket on block and carefully install cylinder head, making sure any valves in open position do not contact block.

4) Install a few head bolts and tighten manually and remove dummy studs. Install remaining head bolts and tighten to specification in sequence shown in illustration.

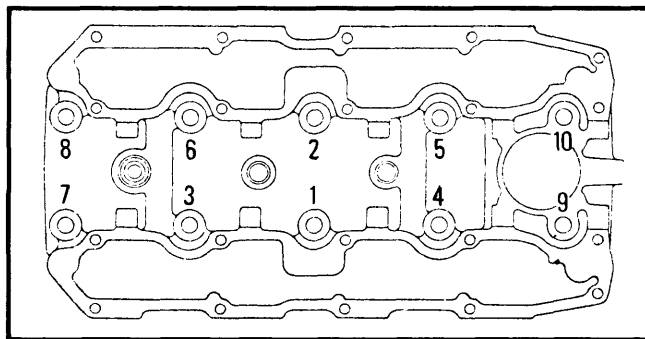

Fig. 1 Cylinder Head Tightening Sequence

VALVES

VALVE ARRANGEMENT

Left Side – All Intake
Right Side – All Exhaust

VALVE GUIDE SERVICING

1) Measure clearance of valve stem in guide with a dial indicator. If clearance exceeds specifications, valve guide must be replaced.

2) With driver (A.60153/60395), remove defective guides from head, driving from combustion chamber side. Press new guide in place from camshaft side with drift (A.60462). Guides are prefinished to size, however minor faults caused during replacement may be hand reamed if necessary.

VALVE SPRING REMOVAL

1) With cylinder head removed, remove camshaft carriers with camshafts. Compress valve spring with a spring compressor and remove both valve keepers.

124 & 131 4 CYLINDER (Cont.)

2) Release spring compressor, remove upper spring retainer, inner and outer springs and lower spring retainer. To assemble cylinder head, reverse disassembly procedure.

VALVE CLEARANCE ADJUSTMENT

1) Valve clearance is checked and/or adjusted with engine cold. Intake valve clearance is .018" (.457 mm). Exhaust valve clearance is .020" (.508 mm).

2) To adjust valves, remove camshaft covers from cylinder head. Rotate crankshaft until camshaft lobe of valve being adjusted is pointing away from valve (valve will be closed).

3) Using a feeler gauge, measure valve clearance. If clearance is not as specified, a thicker or thinner tappet plate must be installed to obtain specified clearance.

4) Tappet plates are available in service thicknesses of .128" (3.25 mm) and from .130" to .185" (3.30 mm to 4.70 mm) in increments of .004" (.10 mm).

5) To replace tappet plate, rotate camshaft until valve is fully open. Insert a suitable tappet hold down tool (A 60422) over lobe of valve being adjusted. Rotate camshaft and remove tappet plate by means of scribe through notch in tappet. Alternately, tappet may be pried down using suitable pry tool (A 60443) and tappet plate may then be removed using scribe.

6) Insert correct thickness tappet plate, rotate camshaft until lobe is resting on tappet plate and remove tool. Use this same procedure for adjusting both intake and exhaust valve clearances.

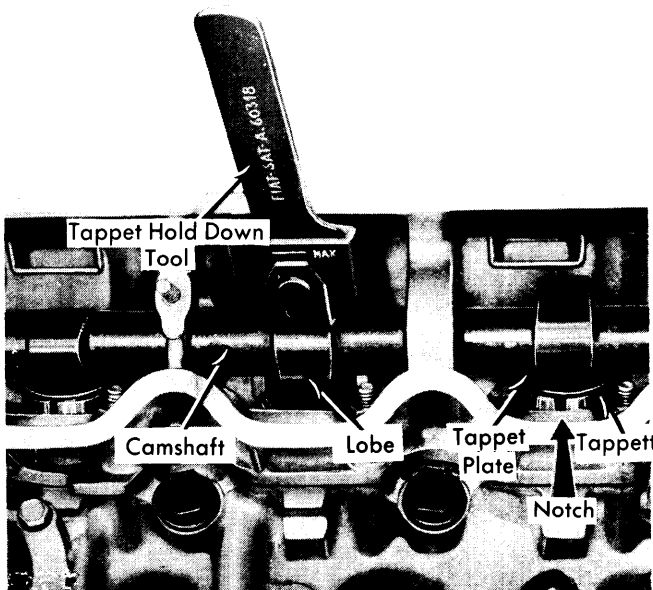

Fig. 2 Correct Procedure to Adjust Valve Clearance

PISTONS, PINS & RINGS

OIL PAN

Raise vehicle and drain crankcase. Remove engine splash shields. Remove pan bolts and strike pan firmly with rubber

mallet to free from block assembly. To install, clean all mating surfaces and install gasket with sealer applied to BOTH sides. Reverse removal procedure and tighten bolts evenly to specification.

NOTE — It may be necessary to disconnect motor mounts and raise engine in order to provide enough clearance to remove pan.

PISTON & ROD ASSEMBLY

1) When installing piston and rod assembly, thoroughly oil piston pin in piston boss. Make sure ring gaps are spaced approximately 120° apart.

2) Lubricate rings and cylinder bore. Compress rings with a ring compressor and install assembly in cylinder block so that numbers on connecting rod and cap are facing away from auxiliary shaft. Tighten connecting rod nuts to specification.

FITTING PISTONS

1) Standard pistons are manufactured in three size classes, and cylinder bores are machined according to piston class. Class of piston and bore is designated by a letter code.

2) Class code of piston is stamped on bottom of piston pin boss. Class of cylinder bore is stamped next to appropriate cylinder on oil pan flange on bottom of cylinder block.

3) Measure piston size at right angles to piston pin and 1.181" (30 mm) from piston skirt. If piston is replaced for any reason, one of the same class must be installed.

NOTE — Refer to class designation letter on bottom of piston pin boss and mating surface of crankcase. (See Figs. 3 and 4).

Std. Piston Class Designation & Size

Class	In. (mm)
A.....	3.3051-3.3055 (83.95-83.96)
C.....	3.3059-3.3063 (83.97-83.98)
E.....	3.3066-3.3070 (83.99-84.00)

4) Measure cylinder bore lengthwise and crosswise near top, center and bottom of bore. Check piston fit in bore at right angles to pin 1.876" (47.65 mm) below piston head using a feeler gauge. If clearance exceeds .0059" (.15 mm), cylinders must be rebored and oversized pistons installed.

Oversize Pistons

Application	Amt. of Oversize In. (mm)
1st Oversize0079 (0.2)
2nd Oversize0157 (0.4)
3rd Oversize0236 (0.6)

NOTE — If replacement pistons are used, ensure that the four pistons are the same weight within ±.18 oz. (±5g).

124 & 131 4 CYLINDER (Cont.)

5) Check ring side clearance in piston grooves prior to installation on piston. Push rings squarely into cylinder bores and check ring gaps with feeler gauge. Install rings on pistons with gaps 120° apart.

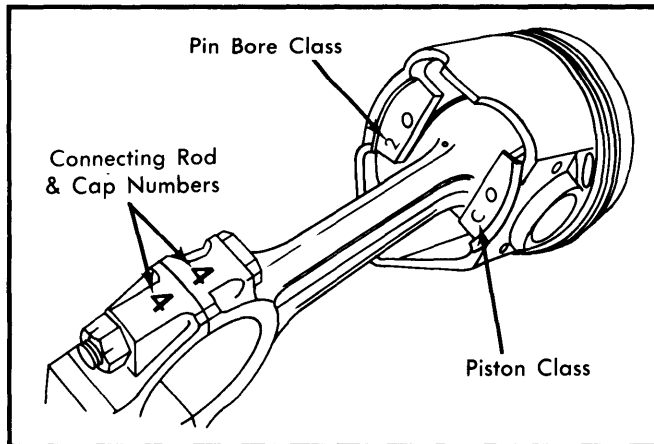

Fig. 3 Piston & Rod Assembly Markings

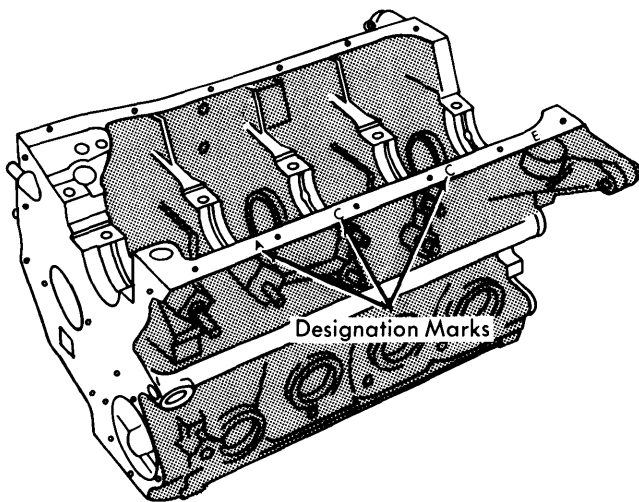

Fig. 4 Piston Bore Class Designation Marks

PISTON PIN REPLACEMENT

- 1) Remove circlips from piston and push piston pin out of piston and connecting rod. Separate piston from connecting rod.
- 2) Check clearance of piston pin in piston and connecting rod. If clearance is excessive, piston and connecting rod must be rebored for a .0079" (.2 mm) oversize pin.
- 3) Bushing in small end of connecting rod is replaceable and requires a .0017-.0040" (.043-.102 mm) interference fit.
- 4) To assemble piston and rod assembly, position piston on connecting rod with side of piston having offset portion of piston pin bore on same side as connecting rod numbers.

5) Oil piston pin and insert in piston and connecting rod. Install circlips and check piston for freedom of movement on pin. Check alignment.

CRANKSHAFT MAIN & CONNECTING ROD BEARINGS

MAIN & CONNECTING ROD BEARINGS

- 1) With crankshaft removed, thoroughly clean and inspect for cracks or scoring on journals. Check all journals for out-of-round condition, using a micrometer. If journal is out-of-round or tapers more than .0002" (.005 mm), crankshaft must be reground for undersize bearings.
- 2) Bearing-to-journal clearance is checked by the Plastigage method. If clearance exceeds specifications, crankshaft must be ground for undersize bearings.
- 3) Main and connecting rod bearings are available in .010" (.25 mm), .020" (.51 mm), .030" (.76 mm), and .040" (1.02 mm) undersizes.

NOTE — Main bearing caps are stamped with a number that must correspond to the number stamped on crankcase near flywheel. Notches on caps face auxiliary shaft side and coincide with position. Front main bearing cap has no notch, however 2nd, center 4th and rear caps have 1, 2, 3, and 4 notches respectively.

CRANKSHAFT END PLAY

- 1) Mount a dial indicator on front of engine and pry crankshaft back and forth to measure crankshaft end play.
- 2) If end play exceeds specifications, adjustment may be made by installing new thrust washers to bring end play within specification.

ENGINE FRONT COVER & OIL SEAL

Engine front cover oil seal should be replaced whenever front cover is removed. Make sure new seal is squarely seated in cover. Lubricate seal contact lip before installing cover.

TIMING BELT REPLACEMENT

- 1) Drain cooling system and remove upper radiator hose. Remove upper section of air duct. Rotate crankshaft until marks on both camshaft sprockets are aligned with fixed pointer on front of engine. Number 4 piston should now be at TDC firing position.
- 2) Place transmission in fourth gear and apply parking brake to prevent crankshaft from turning. **CAUTION** — Do not turn crankshaft or camshafts independent of each other as valves may hit pistons.

124 & 131 4 CYLINDER (Cont.)

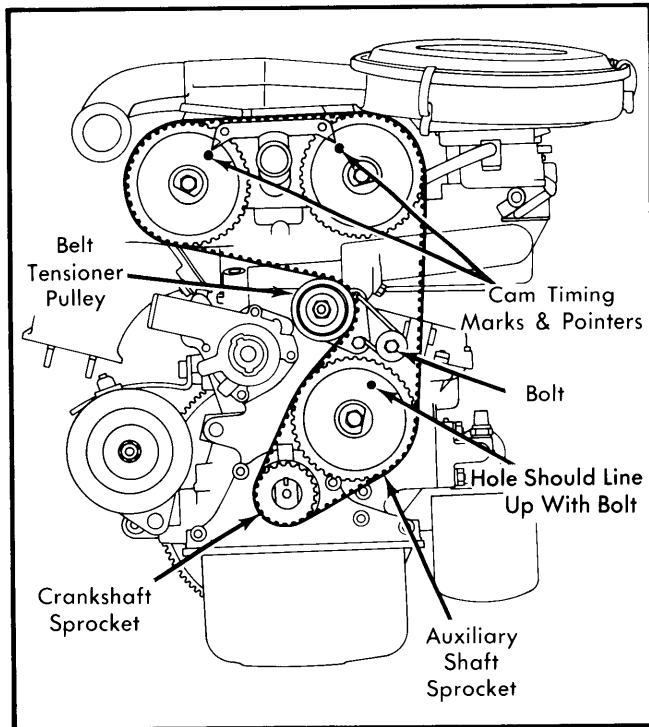

Fig. 5 Camshaft Sprocket Timing Marks

3) Remove lower engine protection plate and all drive belts. Loosen belt idler pulley nut and mounting bracket bolt, release tension on timing belt, tighten pulley nut and bracket bolt and remove belt. **NOTE** – Anytime tension is relieved from timing belt, it must be replaced. Install belt making sure not to move sprockets. Make sure that hole in auxiliary shaft pulley is lined up with tensioner pulley bolt.

4) To adjust timing belt tension, loosen idler pulley tensioner nut and allow pulley to take out play. Rotate crankshaft pulley 2 full turns and recheck timing marks. Tighten tensioner nut and bracket bolt.

CAMSHAFT

CAMSHAFT

With cylinder head removed from engine, remove distributor, manifolds and carburetor assembly. Install pulley holder (A.60446) at front of cam housing and remove bolt, washer and pulley from camshaft. Remove attaching bolts and lift off cam housing with cam. Remove cap from rear of housing and pull out camshaft. Repeat for other side. To install, reverse removal procedure, noting that distributor drive gear is on exhaust camshaft.

AUXILIARY SHAFT

Auxiliary shaft is driven by timing belt and drives oil pump and fuel pump. With engine out of vehicle and front crankshaft pulley removed, take off auxiliary drive pulley. Remove auxiliary shaft cover and gasket. Remove spacer and gasket. Rotate auxiliary shaft to raise oil pump gear and lift gear out with long nose pliers. Remove bolts holding retainer at front of block and pull out shaft along with retainer. To install, reverse removal procedure.

ENGINE OILING

Crankcase Capacity – Total capacity of entire system is 5.2 quarts. Normal drain and refill capacity (with filter) is 4 quarts.

Oil Filter – Full-flow, cartridge type.

Normal Oil Pressure – 64-85 psi (4.5-6 kg/cm²) at idle.

Pressure Regulator Valve – Installed in pump cover.

NOTE – On air conditioned models, oil filter support mounts A/C compressor. Filter screws on from side rather than from bottom.

ENGINE OILING SYSTEM

Engine oiling system is full pressure lubrication utilizing a gear type oil pump driven by auxiliary shaft. A full-flow oil filter and a pressure regulator valve is also employed.

OIL PUMP

1) To remove oil pump, drain oil and remove oil pan. Remove two bolts and washers holding oil pump to engine and remove pump and gasket. Visually inspect all parts for wear or damage.

2) Check gears for tooth-to-housing clearance. Clearance should be .004-.007" (.11-.18 mm). Place straightedge across pump body and measure gear end play. End play should be .0012-.0045" (.031-.116 mm).

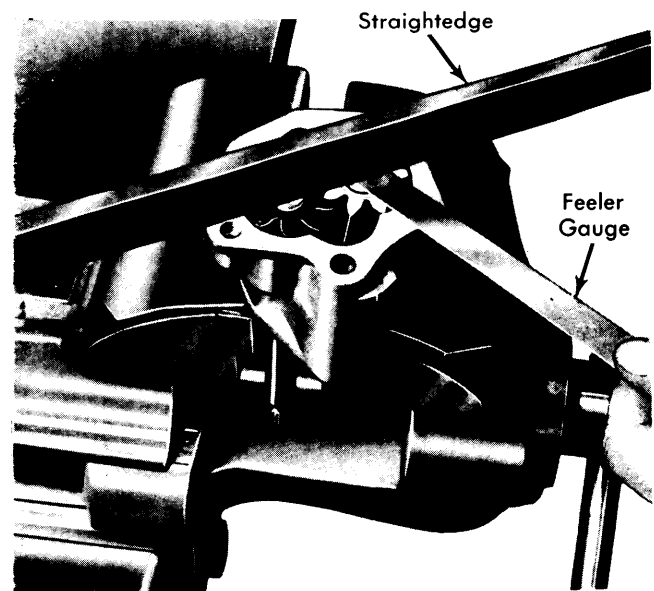

Fig. 6 Checking Oil Pump Gear End Play

3) Check relief valve spring for pressure of at least 9.5 lbs. (4.3 kg) at .886" (22.5 mm). To install, reverse removal procedure and mount pump using a new gasket. Make sure pump is seated before tightening mounting bolts.

Fiat Engines

124 & 131 4 CYLINDER (Cont.)

ENGINE COOLING

Thermostat Opening Temperature - 178-185°F (81-85°C).

Cooling System Capacity - 8.5 qts.

Radiator Cap - 11 psi.

WATER PUMP

To remove water pump, remove alternator and drive belt. Disconnect water hoses from pump and remove three bolts securing pulley on pump. Remove four bolts securing pump to engine and remove pump and gasket. To install, reverse removal procedure and use new gasket.

ENGINE SPECIFICATIONS

GENERAL SPECIFICATIONS										
Year	Displ.		Carburetor	HP at RPM	Torque (Ft. Lbs. at RPM)	Compr. Ratio	Bore		Stroke	
	cu. ins.	cc					in.	mm	in.	mm
1978	107.13	1756	1x2-Bbl.	①86@6200	②90@2800	8.0-1	3.31	84	3.12	79.2

① - 83@5800 when equipped with catalytic converter.

② - 86@2800 on 131 models or 89@2800 on 124 models when equipped with catalytic converter.

VALVES							
Engine & Valve	Head Diam. In. (mm)	Face Angle	Seat Angle	Seat Width In. (mm)	Stem Diameter In. (mm)	Stem Clearance In. (mm)	Valve Lift In. (mm)
1756 cc Int.	1.622-1.638 (41.2-41.6)	45°	45°	.079 (2.0)	.3139-.3146 (7.974-7.992)	.0012-.0026 (.030-.066)	.3765 (9.564)
Exh.	1.412-1.435 (35.85-36.45)	45°	45°	.079 (2.0)	.3139-.3146 (7.974-7.992)	.0012-.0026 (.030-.066)	.3765 (9.564)

VALVE SPRINGS			
Engine	Free Length In. (mm)	PRESSURE Lbs. @ In. (kg @ mm)	
		Valve Closed	Valve Open
1756 cc Inner Spring	1.646 (41.8)	33@1.220 (14.9@31)	62@.846 (28.1@21.5)
Outer Spring	2.122 (53.9)	86@1.417 (38.9@36)	131@1.043 (59.5@26.5)

VALVE TIMING				
Engine	INTAKE		EXHAUST	
	Open (BTDC)	Close (ALDC)	Open (BLDC)	Close (ATDC)
1756 cc	5°	53°	53°	5°

PISTONS, PINS, RINGS						
Engine	PISTONS Clearance In. (mm)	PINS		RINGS		
		Piston Fit In. (mm)	Rod Fit In. (mm)	Rings	End Gap In. (mm)	Side Clearance In. (mm)
1756 cc	.0016-.0024 (.040-.060)	.0001-.0003 (.002-.008)	.0004-.0006 (.010-.016)	No. 1	.0118-.0177 (.30-.45)	.0018-.0030 (.045-.077)
				No. 2	.0078-.0139 (.20-.35)	.0011-.0027 (.030-.070)
				Oil	.0078-.0139 (.20-.35)	.0011-.0024 (.030-.062)

124 & 131 4 CYLINDER (Cont.)

ENGINE SPECIFICATIONS (Cont.)

CRANKSHAFT MAIN & CONNECTING ROD BEARINGS							
Engine	MAIN BEARINGS				CONNECTING ROD BEARINGS		
	Journal Diam. In. (mm)	Clearance In. (mm)	Thrust Bearing	Crankshaft End Play In. (mm)	Journal Diam. ① In. (mm)	Clearance ② In. (mm)	Side Play In. (mm)
1756 cc	2.0860-2.0868 (52.99-53.00)	.0020-.0037 (.050-.095)	No. 5	.002-.012 (.05-.30)	1.9997-2.0001 (50.79-50.80)	.0018-.0031 (.045-.079)

① — Journal diameter is machined in two sizes designated by class codes. Specification given is class "A". Class "B" is smaller by .0004" (.010 mm).

② — Clearance varies according to class of connecting rod journal. Specification given is class "A". Class "B" clearance is larger by .0001" (.002 mm).

CAMSHAFT			
Engine	Journal Diam. In. (mm)	Clearance In. (mm)	Lobe Lift In. (mm)
1756 cc	Front	1.1788-1.1795 (29.94-29.96)	.0019-.0035 (.049-.090)
	Middle	1.8013-1.8020 (45.75-45.77)	.0011-.0027 (.029-.070)
	Rear	1.8171-1.8178 (46.15-46.17)	.0011-.0027 (.029-.070)

TIGHTENING SPECIFICATIONS	
Application	Ft. Lbs. (mkg)
Cylinder Head Bolts	61 (8.5)
Front Main Bearing Cap Bolts	59 (8.2)
Intake & Exhaust Manifold Nuts	18 (2.5)
Intake Manifold Bolts	18 (2.5)
Connecting Rod Nuts	37 (5.1)
Flywheel-to-Crankshaft Bolt	105 (14.5)
Camshaft Sprocket Bolt	87 (12)
Oil Pump Mounting Bolt	14 (2.0)
Tensioner Nut	33 (4.5)