

200SX, 510 & PICKUP 4 CYLINDER

ENGINE CODING

ENGINE IDENTIFICATION

Engine number is stamped on right rear side of cylinder block at cylinder head contact surface. The number is preceded by engine model L20B.

ENGINE, CYLINDER HEAD & MANIFOLD

ENGINE

NOTE — It is recommended that engine and transmission be removed as a unit. Engine can then be separated from transmission.

Model 620 (Pickup) — 1) Remove battery, scribe alignment marks on hood and hinges, then remove hood. Disconnect all hoses and ducts from air cleaner, loosen air cleaner supporting attachments and remove air cleaner.

2) Drain cooling system and remove radiator hoses and oil cooler lines (if equipped). Remove radiator shroud, then remove radiator. Disconnect fuel pump-to-filter and return hoses. Disconnect carbon canister hose on engine side.

3) Disconnect wires to following components: Accelerator wire at carburetor, oil pressure switch, auto choke heater, vacuum control solenoid, coil lead, distributor, thermal transmitter, anti-dieseling solenoid, alternator, starter, and back-up lamp switch.

4) Disconnect power brake unit vacuum hose at intake manifold. Disconnect speedometer cable from rear extension housing. On manual transmissions, remove floor cover, detach rubber boot, remove "E" ring and control lever pin from transmission striking rod guide, remove lever. On automatic transmissions remove screws to disconnect control knob from lever, remove selector rod, range lever and control lever assembly with bracket.

5) On models with air conditioning, remove flexible hose support, remove four compressor bolts, move compressor to battery support. Remove hoses to fast idle control device solenoid valve, remove fast idle control device actuator.

6) Remove attaching screws, disconnect clutch operating cylinder and flexible tube as an assembly. Disconnect exhaust pipe from exhaust manifold. Disconnect center bearing bracket from crossmember and propeller shaft from flange at rear axle. Remove propeller shaft and plug rear end of transmission to prevent oil leakage.

7) Attach a lifting hoist to engine and remove front mount bolts at support. Support transmission with a floor jack and loosen two rear mounting bolts. Remove rear mount to side member bolts, remove rear mount. Remove steering idler arm and push down cross rod. Pull engine forward and carefully remove engine and transmission as an assembly.

Model 200SX, 510 — 1) Mark hood and hinges for alignment on reassembly, then remove hood. Disconnect battery ground cable. Drain cooling system and crankcase. Disconnect transmission oil cooler lines and remove splash board on automatic transmission models.

2) Remove all hoses and tubes to air cleaner, then remove air cleaner. Disconnect the following wires, cables and hoses: Fuel line to fuel pump, carbon canister hoses, high and low tension coil wires, air pump-to-air pump cleaner hose, distributor wires at top of radiator or at connectors, power brake vacuum hose at manifold, accelerator at carburetor, heater inlet and outlet hoses, fast idle control device vacuum hose.

3) On air conditioned models, dismount compressor by removing mounting bolts and moving compressor aside toward fender. DO NOT discharge gas from compressor or system or separate refrigerant lines. Hold compressor out of way with wire to prevent interference with engine removal.

4) Remove accelerator linkage from carburetor. Disconnect heater hoses, remove radiator hoses, shroud, grille and radiator. On manual transmission models, detach rubber boot, remove nut from shift lever, remove shift lever. On automatic transmissions, disconnect joint between control lever and selector rod.

5) Disconnect speedometer cable from extension housing. Remove clutch operating cylinder from clutch housing. On California models, remove heat shield insulators on front exhaust pipe and catalytic converter, then separate front exhaust pipe from converter. All other models, disconnect front pipe from rear pipe.

6) Remove front exhaust pipe mounting and separate pipe from exhaust manifold. Disconnect center bearing bracket from crossmember and propeller shaft from flange at rear axle. Remove propeller shaft and plug end of transmission to prevent oil leakage. Support transmission with a floor jack.

7) Remove rear engine mounts and connect a lifting hoist to engine. Remove front engine mounts. Pull engine forward and carefully remove engine and transmission as an assembly.

CYLINDER HEAD

Removal — 1) Drain cooling system. Remove air cleaner after disconnecting hoses and ducts. Disconnect spark plug wires from spark plugs and valve cover. Disconnect fuel hose from carburetor and remove fuel pump. Remove PCV hose and anti-backfire valve-to-EGR passage hose. Disconnect vacuum hoses and linkage to carburetor, then remove carburetor.

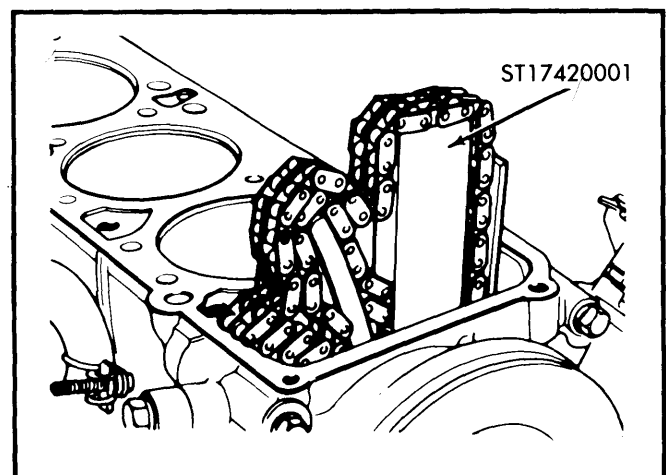

Fig. 1 Holding Timing Chain with Special Support Tool

200SX, 510 & PICKUP 4 CYLINDER (Cont.)

2) Disconnect all hoses and vacuum lines from intake manifold to cylinder head or block. Remove intake and exhaust manifold as an assembly. Remove rocker cover and fuel pump drive cam. Turn crankshaft so No. 1 piston is at TDC on compression stroke. Paint alignment marks on timing chain and camshaft sprocket to aid in installation. Remove camshaft sprocket, and use suitable retainer tool (ST17420001) to support timing chain as shown in Fig. 1. Remove cylinder head attaching bolts and remove cylinder head.

Installation - 1) Ensure that mating surfaces of cylinder head and block are clean, then install cylinder head and gasket without sealer. Number 1 piston should be at TDC on compression stroke and camshaft sprocket location notch and plate oblong groove aligned.

2) Insert head bolts and tighten ① and ② to 14 ft. lbs. (2.0 mkg). Install and align sprockets and timing chain. Install remaining components in reverse order of removal, using new seals, gaskets and sealant where required.

3) Tighten head bolts in several steps in the sequence illustrated in Fig. 2 to final specified torque. Recheck torque after engine has been running for several minutes.

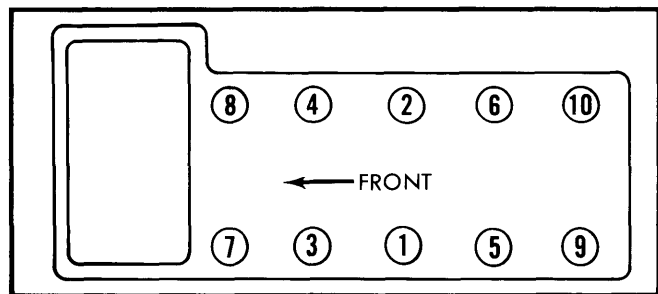

Fig. 2 Cylinder Head Tightening Sequence

VALVES

VALVE ARRANGEMENT

E-I-E-E-I-I-E (front to rear)

NOTE - Camshaft **MUST** be removed to take out valves. See Camshaft Removal & Installation in this Section.

VALVES

Removal - With camshaft removed. Remove valves using suitable valve spring compressor (ST12070000). Take care not to lose valve spring, seat, oil seal, valve collet, and rocker guide. Check each valve for worn, damaged or deformed heads or stems.

Installation - Install oil seal on valve guide. Assemble order, valve, inner and outer valve spring, spring retainer, valve collet and valve rocker guide. Install with suitable valve spring compressor (ST12070000). Make sure that components are clean.

VALVE GUIDE SERVICE

1) Measure clearance between valve stem and valve guide, with aid of micrometer and hole gauge. Check diameter of valve stem in three places: top, center, and bottom.

2) Insert hole gauge in valve guide bore and measure at center. Subtract highest reading of valve stem diameter from valve guide bore to obtain clearance.

NOTE - As a quick check, a valve may be inserted into valve guide and moved either left or right, (parallel with rocker arm). If tip moves .0079" or more, clearance is beyond maximum limit, of .0039".

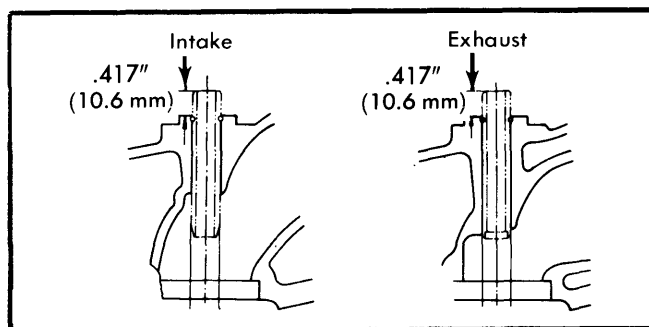

Fig. 3 Intake & Exhaust Valve Guides

VALVE SEAT INSERTS

1) Check valve seats for pitting at valve contact surface. Valve seat inserts of .0197" oversize are available if necessary. To remove old inserts machine should be set so that boring cannot continue beyond bottom face of insert recess in cylinder head.

2) Machine cylinder head recess diameter to concentric circles to valve guide center so that insert will have correct fit. Heat cylinder head to 302-392° F and install insert making sure that it beds on bottom face of recess.

3) Valve seats should be cut or ground to correct face angle and seat width and to head diameter of valve to be installed.

VALVE SPRING INSTALLED HEIGHT

With valves closed, inner spring should have a height of 1.378" (35.0 mm) and outer spring should have a height of 1.575" (40.0 mm). See specification for pressure with valves opened or closed.

VALVE ADJUSTMENT

Loosen pivot locking nut and turn pivot screw until specified clearance is obtained with engine cold. Tighten pivot locking nut after adjustment and recheck clearance. Warm up engine. With engine stopped, measure valve clearance and reset to hot clearances if necessary.

Valve Adjustment Specifications

Valve	Hot	Cold
Intake	.010" (.25 mm)	.008" (.20 mm)
Exhaust	.012" (.30 mm)	.010" (.25 mm)

200SX, 510 & PICKUP 4 CYLINDER (Cont.)

PISTONS, PINS & RINGS

PISTON & ROD ASSEMBLY

Removal — Remove connecting rod nuts and bearing caps. Push piston and rod assembly out top of cylinder, using care not to damage any bearing surface. Retain all components in proper order for reassembly.

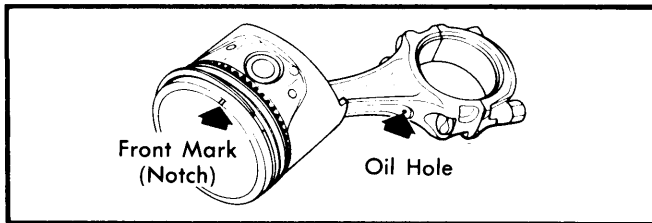

Fig. 4 Piston & Rod Assembly Installation Features

Installation — Reassemble piston and rod so that oil hole in connecting rod is facing right side of engine and notch on top of piston is facing forward. Install connecting rod on original journal with rod and cap marks on same side. Tighten connecting rod nuts and check rod side play.

FITTING PISTONS

1) Measure cylinder bores for wear or taper at top, bottom and middle on thrust face and at 90° to thrust face. If excessive wear is found rebore cylinder and install oversize pistons. Oversize pistons are available as shown in table.

2) When boring cylinders, use cylinder order of 2-4-1-3 to prevent heat distortion. After honing cylinder to final fit, check piston fit using spring tension pull scale. A force of .44-3.31 lbs. (.2-1.5 kg.) should be obtained extracting a .0016" (.04 mm) feeler gauge.

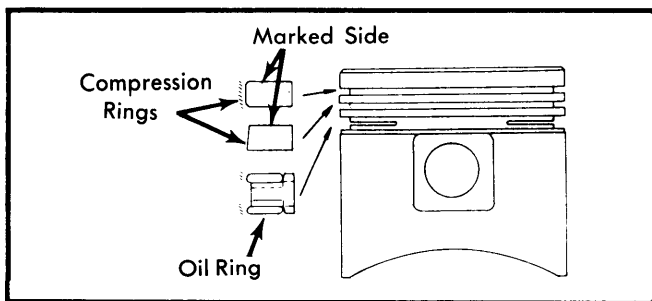

Fig. 5 Installation Order of Piston Rings

3) Measure piston ring end gap and side clearance and replace as necessary. Install rings on pistons with end gaps 180° apart and so no end gap is in line with thrust face. Install rings with top mark facing upward.

NOTE — If only piston ring is to be replaced, measure gap at bottom of bore. Oversize rings are available in .020" (1.00 mm).

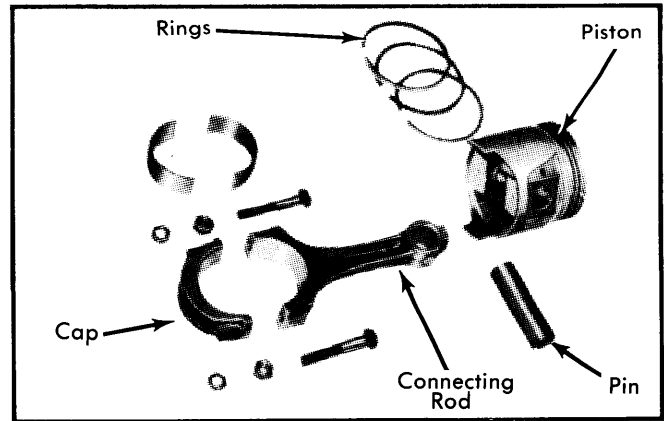

Fig. 6 Exploded View of Piston and Rod Assy.

PISTON PINS

Pin must be a tight press fit in connecting rod, pressing force is from one to one and a half tons. When pressing pin into connecting rod, oil pin and press pin so that oil jet of connecting rod large end is directed toward right side of cylinder block.

Piston Specifications

Application In. (mm)	Piston Size In. (mm)
Standard	3.3459-3.3478 (84.985-85.035)
.020 (.50) OS	3.3648-3.3667 (85.465-85.515)
.040 (1.00) OS	3.3844-3.3864 (85.965-86.015)

CRANKSHAFT MAIN & CONNECTING ROD BEARINGS

CRANKSHAFT

Removal — With engine removed from vehicle, remove cylinder head and oil pan. Remove flywheel and rear plate. Remove oil strainer, oil pump and drive spindle. Remove front cover, chain tensioner, chain slack side guide, and timing chain. Remove oil thrower, crankcase worm gear, and timing drive sprocket. Remove piston and rod assemblies. Remove main bearing caps using suitable puller (KV101041SO) to remove center and rear main bearing caps.

NOTE — Keep all main bearing caps in order to aid in reassembly. Remove rear oil seal, remove crankshaft.

Inspection — Check all crankshaft journals for scoring, wear or cracks. Taper and out-of-round on all journals must not exceed .001" (.025 mm). Check crankshaft for bend using dial indicator at center journal of crankshaft. If bend exceeds .004" (.10 mm), which is one-half of indicator reading, replace crankshaft. Check main driveshaft pilot bearing at rear of crankshaft for wear or damage and replace if necessary.

200SX, 510 & PICKUP 4 CYLINDER (Cont.)

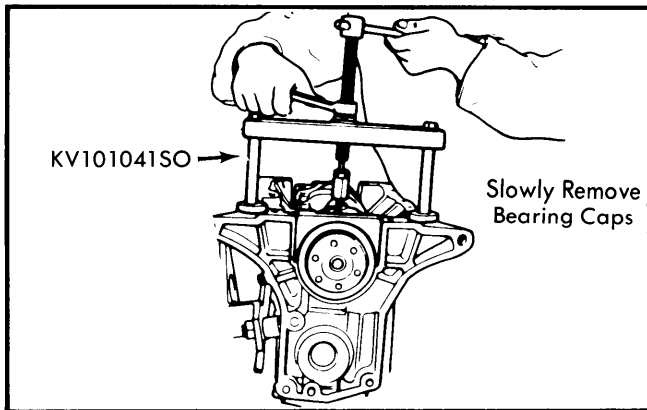

Fig. 7 Rear Main Bearing Cap Removal

Installation - 1) Install main bearing halves to engine block ensuring that all bearings are on correct journal. Journal No. 3 requires a thrust bearing. Bearing for No. 1 is the same as for journal No. 5 except that an oil hole is provided in No. 1. Upper and lower bearings are interchangeable.

2) Apply oil to main bearing surface and install crankshaft. Install main bearing caps with arrow pointing toward front of engine. Shift crankshaft toward front of engine, tighten main bearing caps, in two or three steps, starting at center bearing and working outwards. Ensure crankshaft rotates smoothly.

NOTE - Apply sealer to rear main bearing cap at point where cap contacts cylinder block.

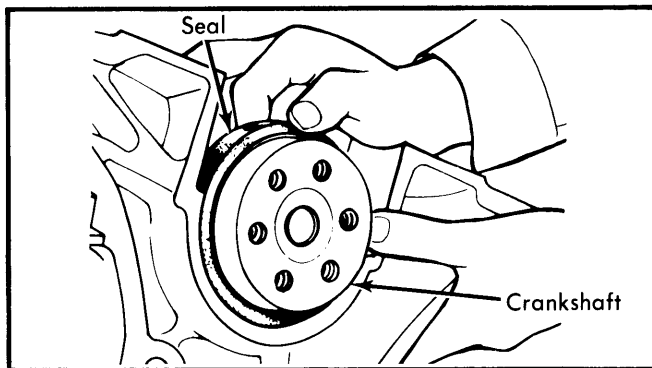

Fig. 8 Rear Oil Seal Removal

3) Check crankshaft end play, and if not within specifications replace center thrust bearing. Install side seals in rear main bearing cap, after applying sealer to seals. Install rear oil seal. Install rear end plate and flywheel. Install piston and rod assemblies. Install remaining components in reverse of removal procedure

MAIN BEARINGS

1) Check all bearings for scoring or wear and replace if damage is found. Clean oil from crankshaft and place a strip of Plastigage on crankshaft journal. Install main bearing cap, with bearing installed, and tighten to 33-40 ft.lbs. (4.5-5.5 mkg).

NOTE - Plastigage should run parallel with crankshaft and not block oil hole. Do not turn crankshaft while Plastigage is inserted.

2) Remove cap and measure width of Plastigage at widest point using gauge provided. If clearance is not to specifications, replace bearings. Bearings are available in undersizes of .01" (.25 mm), .02" (.50 mm); and .03" (.75 mm).

CONNECTING RODS

Check connecting rod bearings in same manner as main bearings using Plastigage. Tighten connecting rod caps to 33-40 ft. lbs. (4.5-5.5 mkg) Bearings are available in undersizes of .01" (.25 mm), .02" (.50 mm) and .03" (.75 mm). Check for clearance of .001-.002" (.025-.055 mm) when installing new bearings. Maximum wear limit for old bearings is .005" (.12 mm).

ENGINE FRONT COVER

Removal - With engine removed from vehicle and mounted on engine stand, remove oil pump and drive spindle. Remove front cover attaching bolts and front cover.

Installation - Apply sealant at mating corners of oil pan, cylinder head and front cover. Oil seal should be coated with engine oil before installation in cover and before cover is installed. Use new gasket and install cover.

NOTE - Check height difference between cylinder block and front cover upper face. Difference must not exceed .006" (.15 mm).

CAMSHAFT

CAMSHAFT

Removal - With cylinder head removed, remove valve rocker springs. Loosen valve rocker pivot lock nuts and remove rocker arms by pressing down on spring. Use care not to lose valve rocker guide. Carefully remove camshaft from cylinder head.

Installation - Carefully install camshaft into cylinder head taking care not to damage bearing. Install camshaft locating plate with oblong groove of plate, facing front of cylinder head. Install camshaft sprocket and tighten attaching bolts. Install remaining components in reverse of removal procedure and tighten all nuts and bolts.

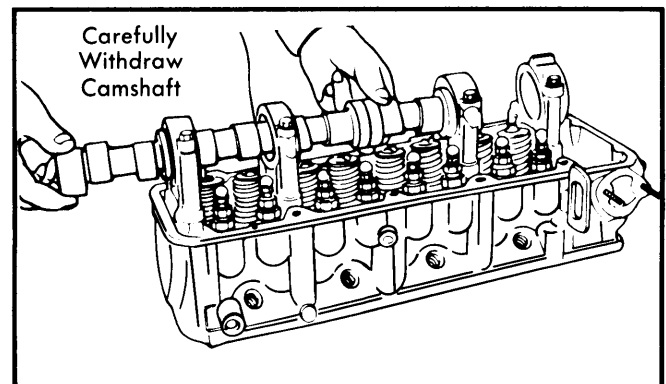

Fig. 9 Withdrawing Camshaft from Cylinder Head

200SX, 510 & PICKUP 4 CYLINDER (Cont.)

CAMSHAFT BEARINGS

Measure inner diameter of camshaft bearing and outer diameter of camshaft journal. If wear or damage is excessive, replace cylinder head assembly.

NOTE — Do not remove camshaft bearings. If bearings are removed, bearing centers will be out of alignment and proper reassembly will be difficult without center boring.

TIMING CHAIN & GEARS

Remove engine front cover and camshaft drive sprocket and fuel pump cam. Remove timing chain, tensioner and chain guide. Remove oil thrower, crankshaft worm gear and crankshaft chain drive gear. To install, reverse removal procedure.

NOTE — When installing timing chain, camshaft key points upward. Set timing chain so that mating marks align with crankshaft and camshaft sprockets. There are 44 chain links between the two timing marks.

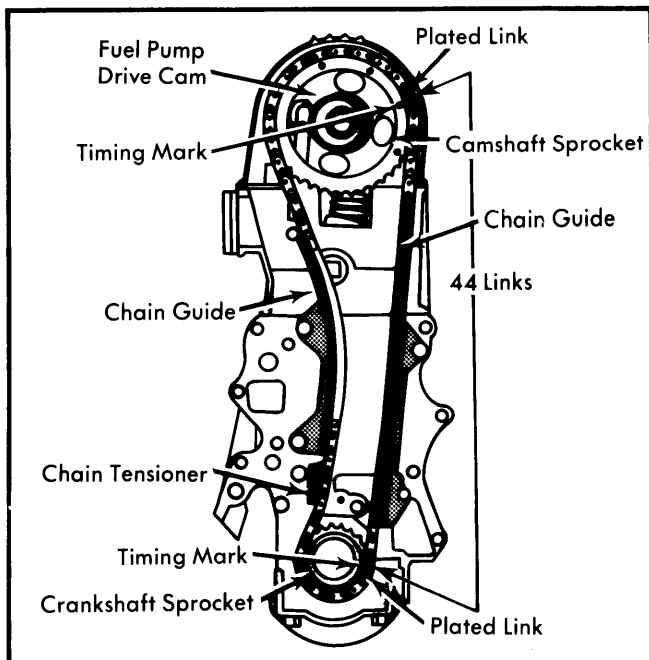

Fig. 10 Timing Chain & Sprocket Alignment

ENGINE OILING

Crankcase Capacity — 4.5 Quarts with filter change.

Oil Filter — Full-flow, disposable cartridge.

Oil Pressure — 11-40 psi. (.8-2.8 kg/cm²) at idle, 50-70 psi. (3.5-5.0 kg/cm²) at maximum.

Pressure Relief Valve — Non-adjustable.

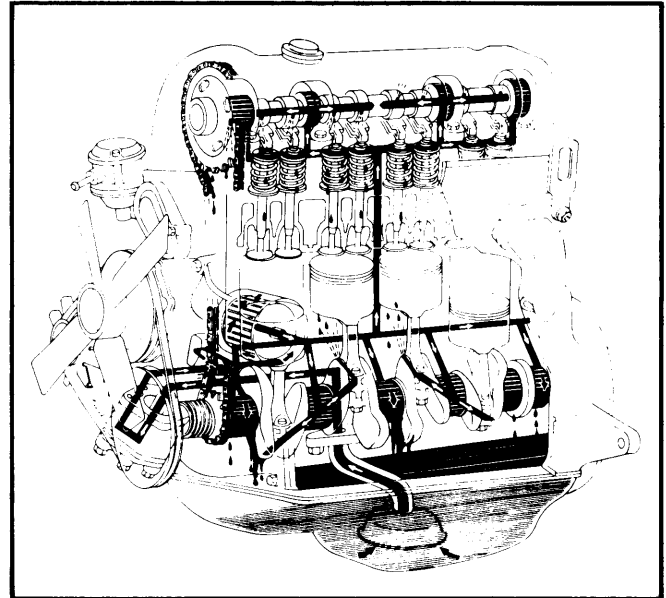

Fig. 11 Cutaway View of Engine Oiling System

ENGINE OILING SYSTEM

Oil drawn from pan passes through screen to oil pump and is delivered to oil filter and to main oil gallery. Main oil gallery supplies oil to crankshaft main bearings and drilled passages in crankshaft. Oil sprayed from jet holes on connecting rods lubricates cylinders and piston pins. Oil from main gallery lubricates chain tensioner and timing chain. Center hole in crankshaft, center bearing feeds camshaft bearings on cylinder head. Valve rocker mechanism is lubricated through oil gallery in camshaft and through a small channel at base circle portion of each cam. Rocker arms and valves are lubricated intermittently through small holes or oil pipe.

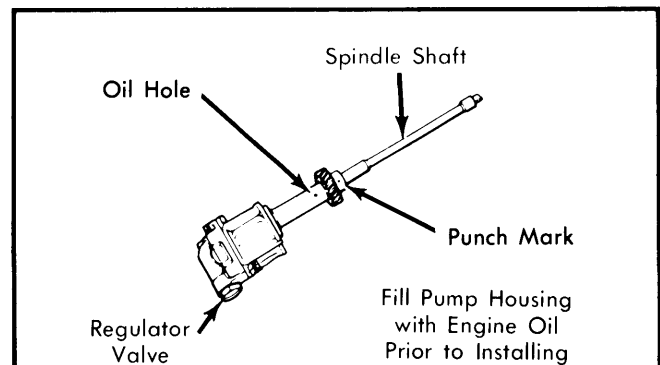

Fig. 12 Aligning Oil Pump Timing Marks

OIL PUMP

Removal — Pump assembly is installed at bottom right of front cover and held in place by four bolts. Pump is driven by helical gear on crankshaft and in turn drives distributor shaft. Remove distributor, splash shield board and pump mounting bolts. Remove oil pump and drive spindle assembly.

200SX, 510 & PICKUP 4 CYLINDER (Cont.)

Inspection — Remove cover from oil pump body, remove gears. Wash parts with cleaning solvent, inspect for wear or damage. Make sure clearances are to specification. Pump is serviced as an assembly only. Replace pump if any part is worn or damaged.

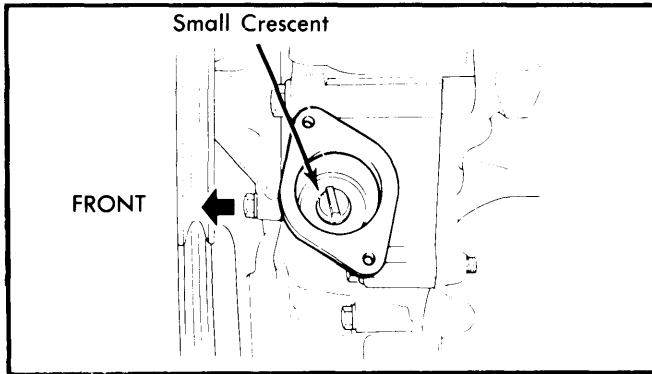

Fig. 13 Position of Distributor and Oil Pump Drive in Engine

Installation — Rotate engine until number one piston is at TDC. Fill pump housing with oil and align punch mark on shaft with hole in pump (Fig. 12). Using a new gasket, install oil pump and drive shaft assembly so that tongue is positioned at 11:25 o'clock position. Small crescent will be facing forward (Fig. 13). Check drive gear engagement through distributor mounting hole.

Oil Pump Specifications	
Application	① Clearance In. (mm)
Rotor Side Clearance (Rotor to Bottom Cover)	0.20 (0.0079)
Rotor Tip Clearance	0.20 (0.0079)
Outer Rotor to Body	0.5 (0.0197)
① — Wear limit specifications given.	

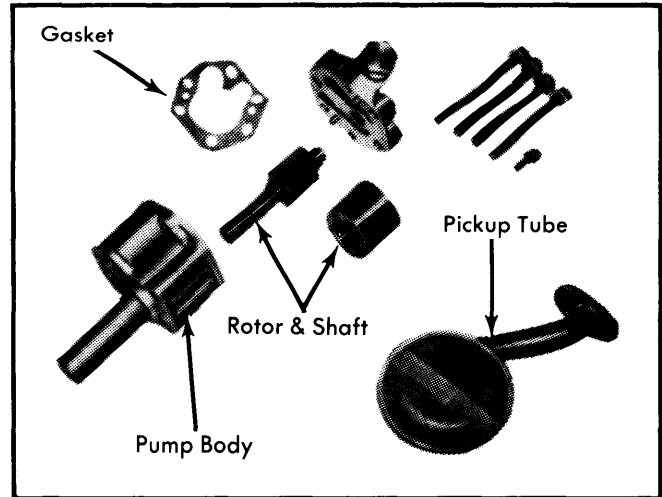

Fig. 14 Exploded View of Oil Pump & Pickup Tube

ENGINE COOLING

Thermostat — Opens at 180° F (82° C). Full open at 203° F (95° C).

Radiator Cap — 13 psi.

Cooling System Capacity — 200SX — 8 qts.; 510 and Pickup 9 qts.

WATER PUMP

Centrifugal type pump with aluminum body. To remove drain cooling system and remove upper and lower radiator hoses, shroud, fan, belts and pulley. Remove pump attaching bolts and remove water pump.

ENGINE SPECIFICATIONS

GENERAL SPECIFICATIONS										
Year	Displ.		Carburetor	HP at RPM	Torque (Ft. Lbs. at RPM)	Compr. Ratio	Bore		Stroke	
	cu. ins.	cc					in.	mm	in.	mm
1978 L20B	119.1	1952	2Bbl.	8.5-1	3.35	85	3.39	86

VALVES							
Engine & Valve	Head Diam. In. (mm)	Face Angle	Seat Angle	Seat Width In. (mm)	Stem Diameter In. (mm)	Stem Clearance In. (mm)	Valve Lift In. (mm)
L20B Intake	1.654-1.661 (42.0-42.2)	45°	45°	.0551-.0630 (1.4-1.6)	.3136-.3142 (7.965-7.980)	.0008-.0021 (.020-.053)	.413 (10.5)
Exhaust	1.378-1.386 (.35.0-35.2)	45°	45°	.0709-.0866 (1.8-2.2)	.3128-.3134 (7.945-7.960)	.0016-.0029 (.040-.073)	.413 (10.5)

Datsun Engines

200SX, 510 & PICKUP 4 CYLINDER (Cont.)

ENGINE SPECIFICATIONS (Cont.)

PISTONS, PINS, RINGS						
Engine	PISTONS	PINS		RINGS		
	Clearance In. (mm)	Piston Fit In. (mm)	⓪ Rod Fit In. (mm)	Rings	End Gap In. (mm)	Side Clearance In. (mm)
L20B	.0010-.0018 (.025-.045)	.0001-.0006 (.003-.015)	.0006-.0013 (.015-.033)	No.1	.010-.016 (.25-.40)	.0016-.0029 (.040-.073)
				No. 2	.012-.020 (.30-.50)	.0012-.0028 (.030-.070)
				Oil	.012-.035 (.30-.90)

⓪ - Interference fit.

CRANKSHAFT MAIN & CONNECTING ROD BEARINGS							
Engine	MAIN BEARINGS				CONNECTING ROD BEARINGS		
	Journal Diam. In. (mm)	Clearance In. (mm)	Thrust Bearing	Crankshaft End Play In. (mm)	Journal Diam. In. (mm)	Clearance In. (mm)	Side Play In. (mm)
L20B	2.3599-2.3604 (59.942-59.955)	.0008-.0024 (.020-.062)	No. 3	.002-.007 (.05-.18)	1.9670-1.9675 (49.961-49.974)	.001-.002 (.025-.055)	.0079-.0118 (.20-.30)

VALVE SPRINGS			
Engine	⓪ Free Length In. (mm)	PRESSURE Lbs. @ In. (kg @ mm)	
		Valve Closed	Valve Open
Inner	1.766 (44.85)	27.1@1.378 (12.3@35)	56.2@.965 (25.5@24.5)
Outer	1.968 (49.98)	47@1.575 (21.3@40)	108@1.161 (49@29.5)

⓪ - If valve spring is out-of-square more than .063" (1.6 mm) replace spring.

CAMSHAFT			
Engine	Journal Diam. In. (mm)	⓪ Clearance In. (mm)	Lobe Lift In. (mm)
L20B	1.8877-1.8883 (47.948-47.963)	.0015-.0026 (.038-.067)	.276 (7.0)

⓪ - End play is .003-.015" (.08-.38 mm).

TIGHTENING SPECIFICATIONS	
Application	Ft. Lbs. (mkg)
Cylinder Head	47-61 (6.5-8.5)
Front Cover	
8 mm bolts	7-9 (1.0-1.3)
6 mm bolts	3-4.3 (.4-.6)
Connecting Rods	33-40 (4.6-5.5)
Flywheel	101-116 (14-16)
Main Bearings	33-40 (4.6-5.5)
Camshaft Sprocket	86-116 (12-16)
Oil Pan	4-7 (.6-.9)
Crankshaft Pulley	86-116 (12-16)
Manifolds	9-12 (1.2-1.7)
Rocker Pivot Lock Nuts	36-43 (5-6)