

LUV

LUV

DESCRIPTION

Axle housing is banjo type with removable differential carrier and semi-floating axle shafts. Ring and pinion gears are hypoid type in which centerline of pinion is set below centerline of ring gear. Differential case is a one piece, two-pinion design. The axle shafts are retained in housing by cone-type roller bearings and bearing retainers at axle housing outer ends.

AXLE RATIO & IDENTIFICATION

All LUV models are equipped with one type of rear axle assembly. To determine axle ratio, divide the number of ring gear teeth by the number of drive pinion gear teeth.

REMOVAL & INSTALLATION

AXLE SHAFTS & BEARINGS

Removal — Raise vehicle and remove wheel and tire assembly. Remove brake drum, brake shoes, and disconnect parking brake inner cable. Disconnect brake line from wheel

cylinder and cover end to prevent loss of fluid and entry of dirt. From inboard side of brake backing plate, remove four nuts from the bearing holder through bolts. Pull axle shaft from housing.

Bearing Replacement — 1) Flatten locking tab of lock washer, then mount axle shaft in a vise, clamping vise jaws around lock nut. Using a suitable tool (J-24246) positioned on lug bolts, turn axle shaft loose from lock nut. Mount axle assembly in a press and remove lock nut, lock washer, bearing and holder, and brake backing plate. Remove oil seal from outboard side of bearing holder, then drive off bearing outer race with a drift.

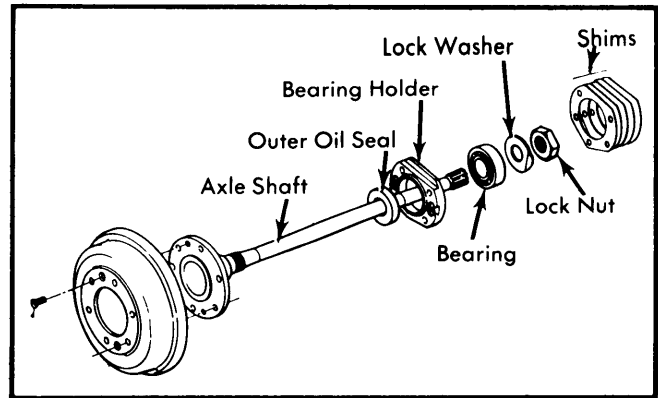

Fig. 2 Exploded View of Axle Shaft Assembly

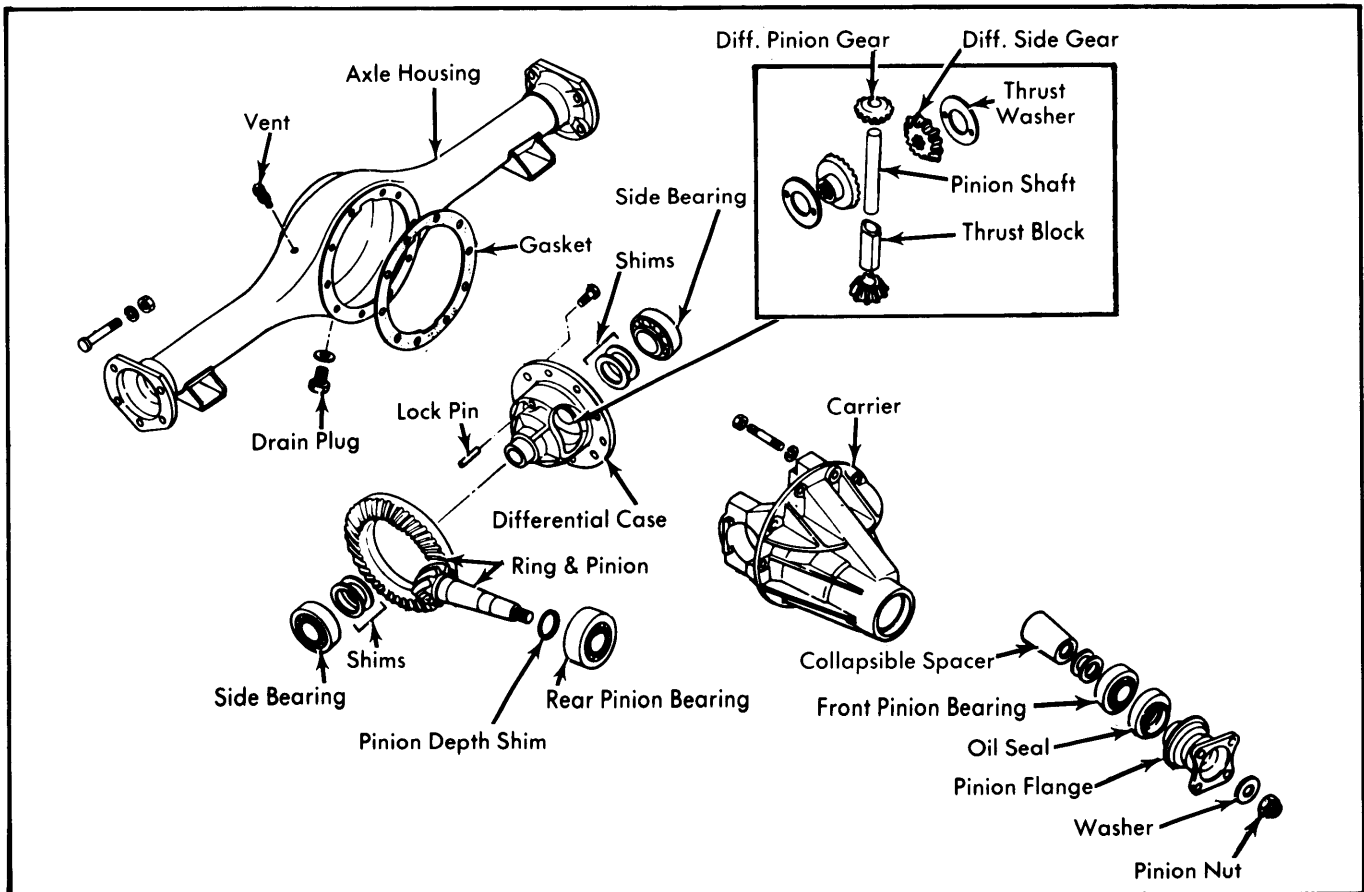

Fig. 1 Exploded View of LUV Rear Axle Assembly

LUV (Cont.)

2) To reassemble, install bearing outer race and grease seal into bearing holder using suitable drivers. Apply wheel bearing grease to bearing holder, rear axle tube, and bearing inner race. Insert the four through bolts into backing plate, then install bearing holder to backing plate, making sure oil seal side of bearing holder is against backing plate. Place backing plate assembly over axle shaft, position bearing over axle shaft and press into bearing holder. Install new lock washer with dished side away from bearing, and thread lock nut onto shaft. Place lock nut between vise jaws, and using tool used during disassembly, tighten lock nut securely. Bend over portion of lock washer opposite to locating tab to prevent lock nut from turning.

Installation – 1) If both axle shafts were removed, insert a .079 (2 mm) shim between bearing holder and axle tube flange of first axle shaft to be installed. Insert shaft into axle tube and install and tighten bearing holder-to-flange bolts. For the second axle shaft (or if only one shaft was removed), insert shaft without shims into axle tube until it comes into contact with thrust block in differential. Measure clearance between bearing holder and axle tube flange (see illustration).

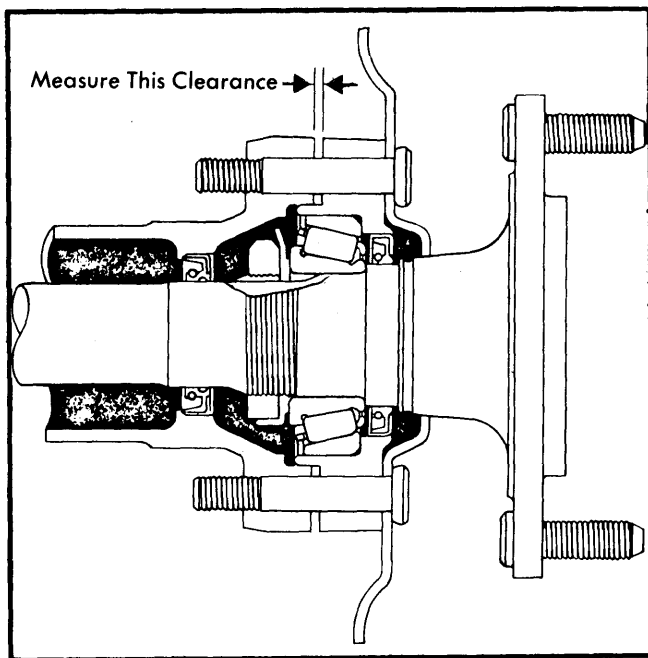

Fig. 3 Sectional View of Axle Shaft Bearing Assembly Measurement for Axle Shaft Shim Requirements

2) Proper size shim for this location may be determined by adding .004" (.1 mm) to measurement just obtained. Select a shim or combination of shims, withdraw axle shaft, and install shims between bearing holder and flange face. Reinstall axle shaft and tighten four through bolts. Connect brake line to wheel cylinder, then install brake shoes, parking brake cable, and brake drum. Install wheel and tire assembly, adjust brakes and bleed system.

DIFFERENTIAL CARRIER

Removal & Installation – Raise rear of vehicle, remove wheels and brake drums, and disconnect brake lines at rear wheel cylinders. Disconnect parking brake cable brackets at rear spring location, remove four through bolts from each end flange, and partially withdraw axle shafts from axle tubes.

Disconnect propeller shaft from pinion flange and place out of way. Remove nuts attaching carrier to axle housing and remove carrier assembly. To install, reverse removal procedure, making sure to refill axle with lubricant.

OVERHAUL

DISASSEMBLY

1) Mark side bearing caps for reassembly reference, remove nuts and bearing caps, then remove differential case assembly. **NOTE** – Keep right and left side bearing races with respective bearings. Remove differential side bearings from case using a suitable puller and adapter (J-22888 and J-8107-2). Record thickness of each side bearing and each shim pack, then place with appropriate bearing race.

2) Remove ring gear bolts and separate ring gear from case. Drive out pinion shaft lock pin using a long drift. **NOTE** – It may be necessary to remove caulking in lock pin using a 5 mm drill. Remove pinion shaft using a drift, then withdraw thrust block, pinion gears, side gears, and thrust washers.

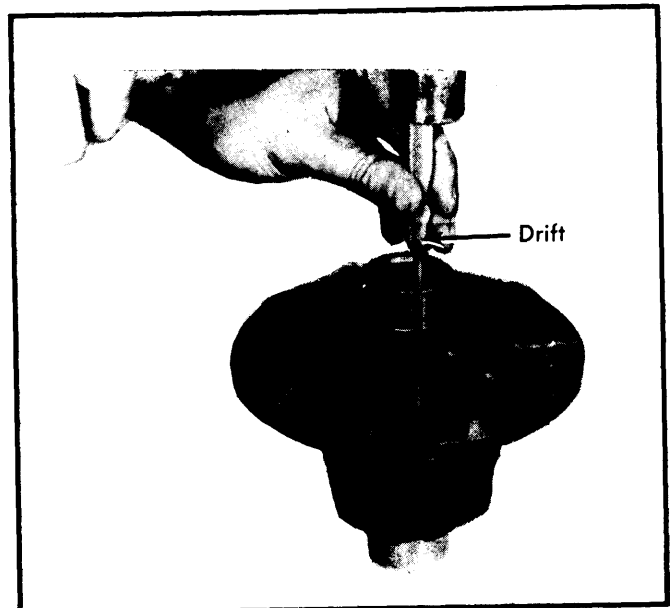

Fig. 4 Removing Pinion Shaft Lock Pin

3) Remove pinion nut and pinion flange. Drive the pinion gear from carrier using a soft hammer or drift. Withdraw front pinion bearing and oil seal. Using a drift, remove pinion bearing races from carrier. Mount pinion gear in a press and remove rear pinion bearing and depth shim from pinion gear.

REASSEMBLY & ADJUSTMENT

Drive Pinion Depth – 1) Install front and rear pinion bearing races into carrier bores, lubricate pinion bearings, and position in respective races. Install a suitable gauging plate (J-23597-7) and preload stud and pilot (J-23597-9) through pinion bearings and tighten nut snugly. Rotate bearings to insure proper seating, then tighten lock nut until

LUV (Cont.)

20 In. Lbs. (25 cmkg) of torque are required to rotate new bearings, or 8-10 In. Lbs. (9.2-11.5 cmkg) are required to rotate used bearings.

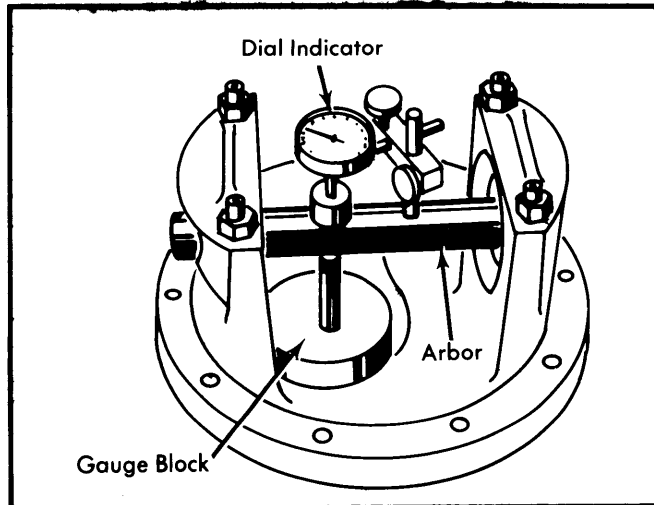

Fig. 5 Tool Arrangement for Measuring Drive Pinion Installed Height

2) Place mounting discs (J-23597-8) onto arbor tool (J-23597-1) and place assembly in position in side bearing bores. Install bearing caps. Mount a dial indicator on arbor post, preload dial $\frac{1}{2}$ revolution, then tighten indicator in this position. Position indicator plunger on gauge plate, slowly swing across until highest reading is obtained, then "zero" indicator on highest reading of gauge plate. Swing plunger off gauge plate and note indicator reading. Reading is the correct thickness of rear pinion bearing depth shim for a nominal drive pinion. **NOTE** — Shims are available in sizes from .086" to .101". An indicator reading of .000" or .001" requires shims of .100" and .101" respectively.

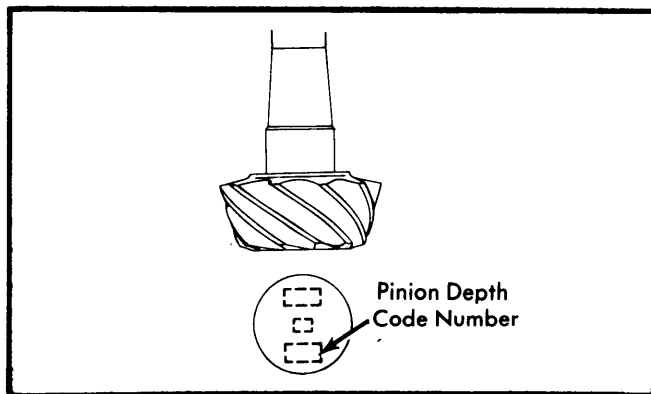

Fig. 6 Location of Pinion Depth Code on Head of Drive Pinion

3) Examine head of drive pinion; pinion depth code is stamped by chemical ink and is the lower of three numbers. A "+" (plus) number indicates need for greater mounting distance (decreased shim thickness), while a "-" (minus) number indicates need for smaller mounting distance (increased shim thickness). See following chart to determine proper shim variation to compensate for plus or minus markings. **NOTE** — If no pinion depth code is present, pinion is "nominal" and no correction to dial indicator reading is required.

Pinion Depth Shim Chart

Pinion Code	Correction Required
+10	Subtract .005" (.13 mm)
+8	Subtract .004" (.10 mm)
+6	Subtract .003" (.08 mm)
+4	Subtract .002" (.05 mm)
+2	Subtract .001" (.03 mm)
0	No Correction Required
-2	Add .001" (.03 mm)
-4	Add .002" (.05 mm)
-6	Add .003" (.08 mm)
-8	Add .004" (.10 mm)
-10	Add .005" (.13 mm)

4) Place selected shim on drive pinion and press rear bearing on pinion. **NOTE** — Do not press on roller cage; press only on bearing inner race. Remove gauging tools from carrier.

Pinion Bearing Preload (W/Collapsible Bearing Spacer)

— 1) Place drive pinion and collapsible spacer into carrier, then install front pinion bearing and oil seal. Mount pinion flange on drive pinion, apply lubricant to pinion threads, install pinion nut and tighten to 85 ft. lbs. (11.3 mkg). Rotate pinion to insure bearings are seated, then wind a small amount of string (approximately 4-6 windings) around pinion flange. Using a pull scale, note reading required to rotate flange.

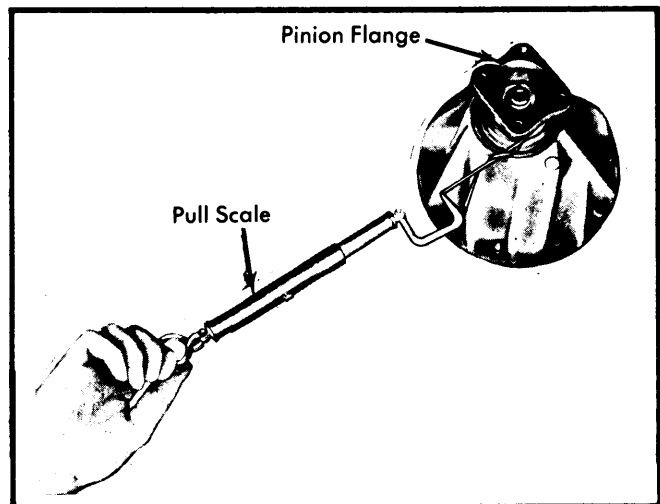

Fig. 7 Using Pull Scale to Measure Drive Pinion Bearing Preload

2) Continue tightening nut in small increments until pull required to rotate flange is 17 lbs. (7.7 kg) for new bearings or 7-9 lbs. (3.2-4.1 kg) for reused bearings. **CAUTION** — Preload builds quickly. Nut should be tightened only in small increments and pull scale used after each small amount of tightening. If preload is exceeded, a new collapsible bearing spacer must be installed.

Case Assembly — Install side gears and thrust washers in case. Position thrust washers 180° apart, then roll gears into position making sure they are in alignment to allow installation of pinion shaft. Place thrust block between pinion gears and drive pinion shaft into position, making sure roll pin hole aligns with hole in case. Measure backlash between side gears and pinion gears; if greater than .003" (.08 mm), install selective thrust washers to bring backlash within specifications. Washers are available in thicknesses of .037" (.94 mm), .041"

LUV (Cont.)

(1.04 mm), and .045" (1.14 mm). **NOTE** — Increasing washer thickness decreases backlash; decreasing washer thickness increases backlash. Install lock pin into pinion shaft and caulk end to prevent loosening. Install ring gear into position on case, apply Loctite to bolt threads, and install and tighten ring gear to case bolts in a diagonal sequence.

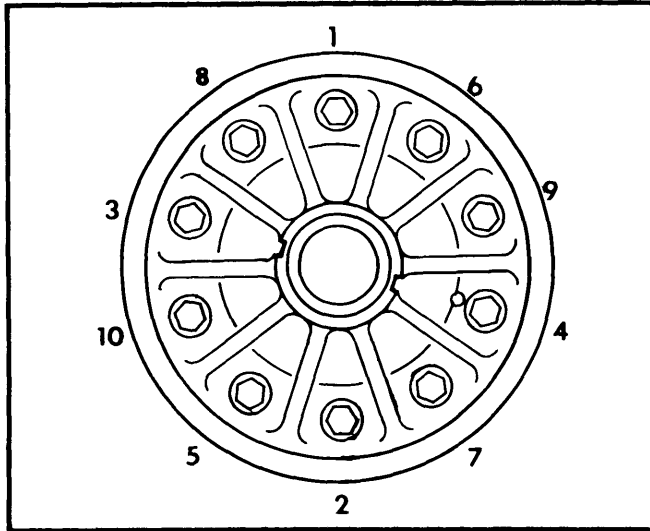

Fig. 8 Ring Gear Bolt Tightening Sequence

Backlash & Side Bearing Preload — 1) If original side bearings, differential case, ring and pinion, and differential carrier are being reused, the original shims may be reinstalled in their respective positions. If only new side bearings are being installed, measure new bearings with a micrometer and compare thickness with original bearings. If new bearing is thicker, **SUBTRACT** difference from shim pack. If new bearing is thinner, **ADD** difference to shim pack.

2) If new bearings, and/or differential case, ring and pinion, or differential carrier are being installed, new shims must be selected as follows: Install side bearings onto differential case, but do not install shims at this time. Mount case into carrier bores. Move ring gear tightly against carrier on ring gear side (away from pinion), and hold in this position. Using a feeler gauge, measure clearance between bearing and differential carrier on side opposite ring gear. Record clearance.

3) Proper preload is established using the predetermined dimension of .002". Therefore, **ADD** this dimension to clearance obtained in step 2) for proper preload. This will give required total thickness of **both** shim packs. Equally divide the total dimension for required shim pack thickness for each side.

4) Remove case from carrier, remove side bearings and install shim packs, then reinstall bearings. Install differential case into carrier, tapping carefully into place. Install side bearing caps in original positions, install and tighten attaching bolts. Measure run-out of ring gear (see illustration). If run-out exceeds .002" (.05 mm), correct by cleaning or replacement of parts.

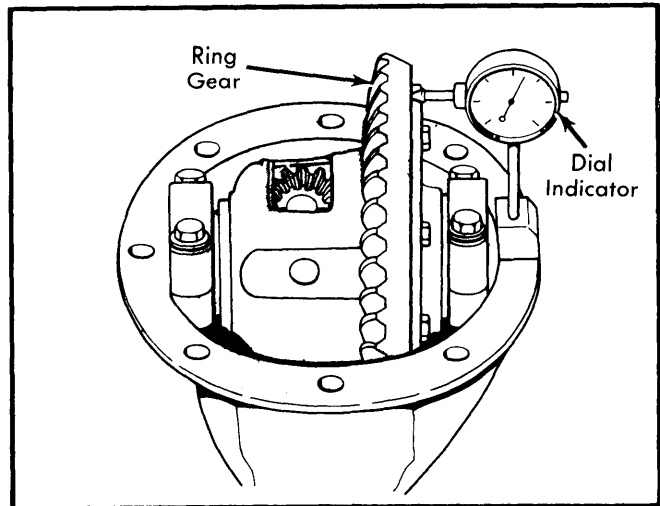

Fig. 9 Checking Ring Gear Backface Runout

5) Mount a dial indicator against ring gear teeth and measure backlash in three locations. Backlash should be .005-.007" (.13-.18 mm); if not, shims behind side bearings must be adjusted. **NOTE** — To maintain preload when backlash is adjusted, the total thickness of both shim packs must not be altered. Therefore, if it is necessary to increase one shim pack, the opposite shim pack must be decreased by the same amount. To increase backlash, right side bearing shim must be increased, and left side decreased. To decrease backlash, right side shim must be decreased, and left side increased. **NOTE** — Backlash changes approximately .002" (.05 mm) for each .003" (.08 mm) shim change. After adjustment, make a gear tooth pattern check to insure correct assembly.

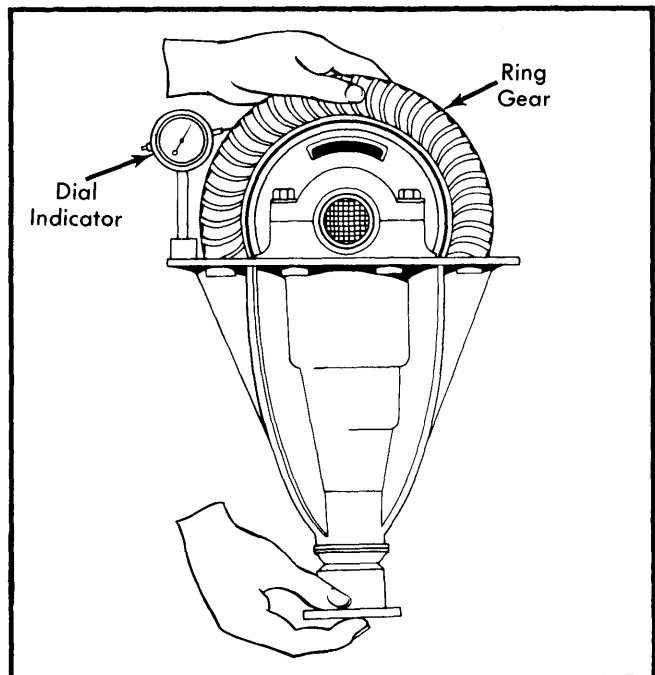

Fig. 10 Checking Ring Gear-to-Drive Pinion Gear Backlash

Drive Axles

LUV (Cont.)

AXLE ASSEMBLY SPECIFICATIONS

Application	Measurement
Pinion Bearing Preload Preload	
New Bearings	17 Lbs. (7.7 kg)①
Used Bearings.....	7-9 Lbs. (3.2-4.1 kg)①
Side & Pinion Gear Backlash.....	.003" (.08 mm) Max.
Side Bearing Preload.....	.002" (.05 mm)②
Ring-to-Drive Pinion Backlash.....	.005-.008" (.13-.18mm)
① — Measured with pull scale.	
② — Add to side bearing "zero clearance" shim pack.	

TIGHTENING SPECIFICATIONS

Application	Ft. Lbs. (mkg)
Propeller Shaft-to-Pinion Flange	18 (2.5)
Axle Shaft Lock Nut	190 (26.3)
Axle Bearing Holder Through Bolts	55 (7.6)
Ring Gear-to-Case Bolts.....	80-87 (11.1-12)
Bearing Cap Nuts.....	75 (10.4)
Carrier-to-Housing Bolts	18 (2.5)
Pinion Flange Nut	85 (11.8)①
① — Initial torque only.	