

VOLKSWAGEN RABBIT/SCIROCCO

Rabbit
Scirocco

DESCRIPTION

Clutch is a single plate dry disc type, using a diaphragm type pressure plate and a transmission mounted clutch release bearing. Clutch is cable operated.

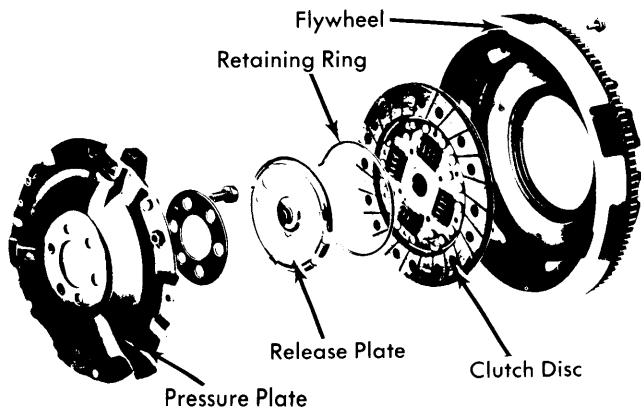

Fig. 1 Exploded View of Clutch and Flywheel Assembly

REMOVAL & INSTALLATION

TRANSMISSION

1) Disconnect battery ground strap and attach an engine support assembly. Remove four attaching bolts and left transmission mount. Remove TDC sender unit and rotate flywheel until flywheel lug appears in sender unit hole. **NOTE** — Engine and transmission can be separated only when flywheel is in this position.

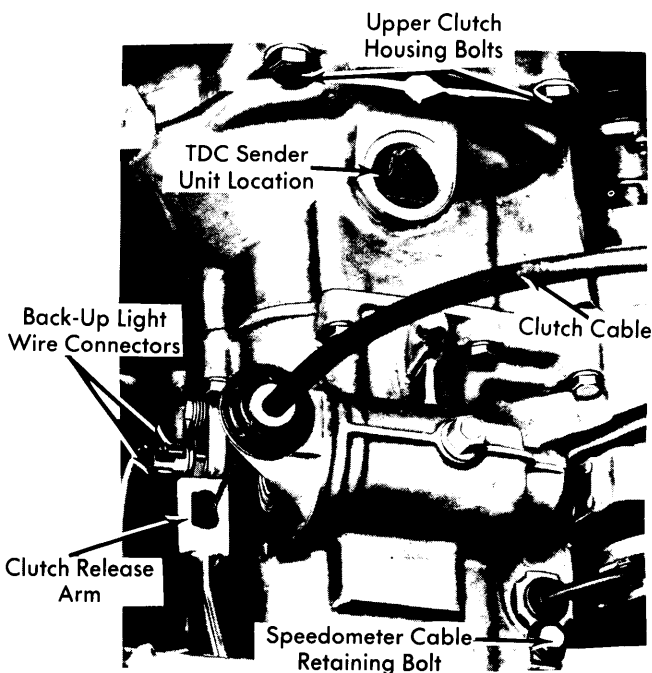

Fig. 2 Top View of Transmission and Clutch Housing
Note Where Clutch Cable Mounts on Transmission Case

2) Disconnect speedometer drive cable and plug hole in transmission with a rubber cap. Disconnect back-up light wires and clutch cable. Remove two upper clutch housing-to-engine bolts. Disconnect shift linkage from rod lever and relay lever.

3) Disconnect ground strap from transmission. Remove starter and engine mount next to starter. Remove lower transmission mount. Disconnect left and right drive shafts and hang aside with wire. While supporting transmission, remove bolts from large housing plate and small housing plate (large housing plate remains on engine). Slide transmission from locating dowels and lower out bottom of vehicle. To install, reverse removal procedure making sure recess in flywheel is level with drive shaft flange. Adjust clutch cable so that clutch pedal has $\frac{5}{8}$ " (15.87mm) of free play.

CLUTCH ASSEMBLY

1) Using a diagonal loosening pattern, gradually loosen and remove flywheel bolts and flywheel. Pry retaining ring from release plate and lift release plate from pressure plate.

NOTE — A special dual purpose holding tool (VW558) may be used to lock either flywheel or pressure plate for removal purposes.

2) Remove bolts attaching pressure plate to engine. Use Loctite 270 or 271 when installing pressure plate bolts. If a new flywheel is to be installed a new timing mark must be cut into flywheel $\frac{1}{4}$ " (6 mm) to right of TDC mark. Install clutch assembly in reverse of disassembly with ends of retaining ring between two slots in release plate. Use a centering disc (VW 547) to center clutch disc in flywheel.

CLUTCH RELEASE BEARING

NOTE — It is not necessary to remove transmission from engine to replace clutch release bearing as bearing is located on opposite end of transmission from clutch assembly.

Remove cover plate from transmission. Disconnect clutch cable and rotate clutch arm until clutch lever is clear of release bearing. Lift out release bearing. Inspect clutch push rod for signs of wear or burning. To install, reverse removal procedure.

ADJUSTMENT

CLUTCH PEDAL FREE PLAY

Adjust cable housing at transmission until there is $\frac{5}{8}$ " (15.87 mm) of free play at clutch pedal.

TIGHTENING SPECIFICATIONS

| Application | Ft. Lbs. (mkg) |
|-----------------------------------|----------------|
| Transmission-to-Engine | 47 (5.5) |
| Drive Shaft-to-Transmission | 32 (4.5) |
| Pressure Plate Bolts | 54 (7.5) |
| Flywheel Bolts | 14 (2.0) |
| Cover Plate | 11 (1.5) |