

## TOYOTA EXCEPT LAND CRUISER

Celica  
Corolla  
Corona  
Pickup

## DESCRIPTION

Clutch is a dry, single plate, diaphragm spring type. Clutch actuation is hydraulic, using a firewall mounted master cylinder and a clutch housing mounted slave cylinder. A pre-lubricated clutch release bearing is also used.

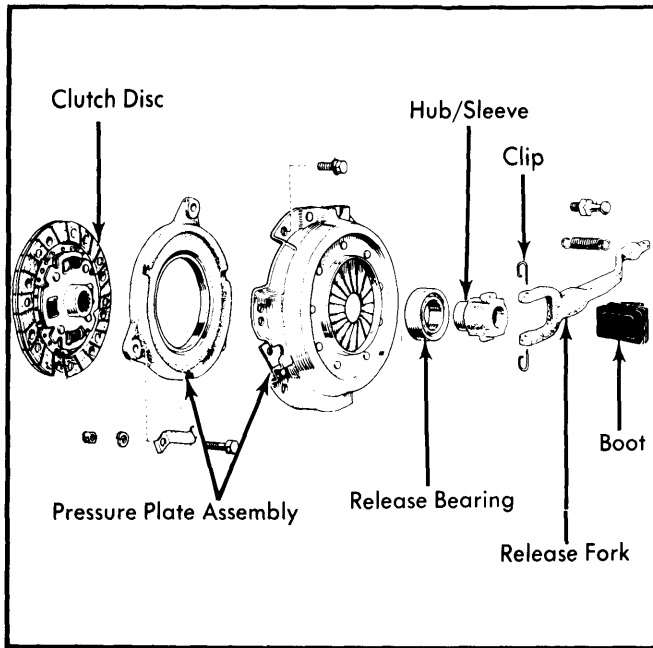

Fig. 1 Exploded View of Typical Clutch Arrangement

## REMOVAL &amp; INSTALLATION

## CLUTCH ASSEMBLY

**NOTE** — Engine removal procedures are of a general nature written to cover all Toyota models.

**Removal** — 1) Disconnect battery cable. Remove air cleaner and drain cooling system, then disconnect top radiator hose. Disconnect accelerator control rod linkage. Remove shift lever boot and shifter assembly. Remove starter.

2) Raise vehicle and support at front and rear with jack stands. If equipped, remove protective cover from under engine.

3) Remove clutch slave cylinder, but only disconnect hydraulic line if necessary. Disconnect exhaust pipe support bracket from mounting and separate exhaust pipe from manifold. Disconnect speedometer cable and electrical leads from transmission.

4) Scribe index marks on drive shaft and coupling for reinstallation reference, then remove drive shaft. Insert suitable plug into extension housing to prevent oil spillage.

5) Support transmission using a floor jack and remove rear support crossmember. Lower jack and remove bolts mounting

transmission to engine. Index mark clutch assembly and flywheel for reassembly. Loosen bolts securing clutch assembly alternately and evenly until pressure is released from clutch. Lift out clutch assembly.

**Installation** — To install, reverse removal procedure and note the following: Use a suitable aligning tool to center clutch disc on flywheel. Tighten clutch pressure plate attaching bolts alternately and evenly in a diagonal progression. With transmission installed, adjust clutch.

## CLUTCH MASTER CYLINDER

**Removal** — Remove cotter pin and clevis pin connecting master cylinder push rod to clutch pedal, then disconnect push rod. Disconnect hydraulic line from cylinder, remove cylinder attaching nuts at firewall, and remove cylinder from vehicle.

**Installation** — To install, reverse removal procedure and note the following: When installing master cylinder, make sure rubber boot hole faces downward. Adjust pedal height and free play, and bleed hydraulic system.

## CLUTCH SLAVE CYLINDER

**Removal** — Raise front of vehicle and support with safety stands. If equipped, remove protective cover under engine. Remove return spring and disconnect hydraulic line. Back off push rod and remove slave cylinder attaching nuts and slave cylinder.

**Installation** — To install, reverse removal procedure and note the following: After installing slave cylinder, adjust free play at release lever and bleed hydraulic system.

## CLUTCH RELEASE BEARING

**Removal** — With transmission removed, check release bearing for freedom of rotation with bearing still installed on hub. To remove, disconnect spring clips from bearing collar and slide bearing off transmission input shaft. Use a press to remove and install bearing on collar.

**Installation** — Slide bearing and collar over transmission input shaft and secure to release lever with new retaining clips. Apply grease to diaphragm spring contact points before installing transmission.

## PILOT BEARING

**Removal** — With transmission and clutch assembly removed, check pilot bearing in crankshaft for roughness or noise. If required, remove bearing using a suitable puller (09303-35010).

**Installation** — Apply grease to new bearing and install into crankshaft using a suitable driver (09304-30012 for Corona and Hi-Lux models, or 09304-12011 for all other models).

## OVERHAUL

## CLUTCH MASTER CYLINDER

**Disassembly** — 1) With cylinder removed from vehicle, clamp it into a soft jawed vise. Remove reservoir, snap ring, and push rod. Pull out piston, cup, and remaining internal components. Further disassemble piston by prying up spring retainer and separating retainer from piston.

## TOYOTA EXCEPT LAND CRUISER (Cont.)

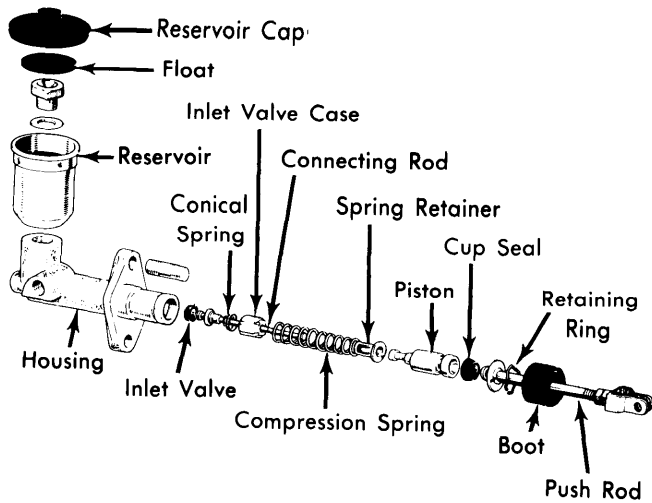

**Fig. 2 Exploded View of Clutch Master Cylinder**  
Celica, Corona, Corolla Shown

**Inspection** — Wash all parts in clean brake fluid. Check master cylinder piston to bore for a clearance of .006" (.15 mm); replace components as necessary. Check compression spring for distortion or weakening and reservoir for damage. Make sure vent hole in reservoir is open.

**Reassembly** — Dip cylinder cups into clean brake fluid or coat with rubber grease before assembly. Assemble piston components in reverse order of disassembly. Install piston assembly, push rod, and reservoir into master cylinder.

### CLUTCH SLAVE CYLINDER

**Disassembly** — With slave cylinder removed from vehicle, remove rubber boot and push rod. Remove piston and cups, then remove bleeder screw.

**Inspection** — Thoroughly clean all parts with clean brake fluid and inspect for wear or damage. **NOTE** — *Manufacturer recommends replacing seals each time slave cylinder is disassembled.*

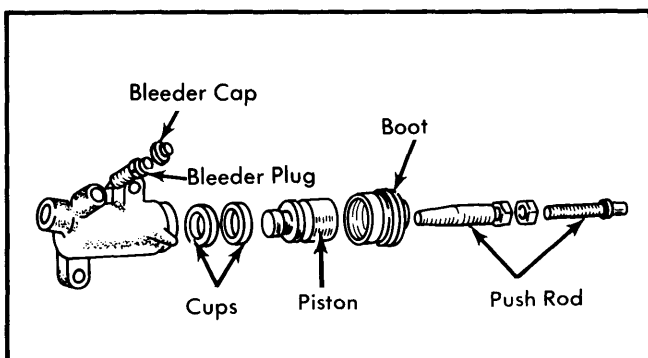

**Fig. 3 Exploded View of Slave Cylinder**  
Pickup Cylinder Shown — Other Similar

**Reassembly** — Soak all parts in clean brake fluid before assembly. Install seals on piston, then install piston into cylinder. Install rubber boot and push rod. Install bleeder screw and cap.

### ADJUSTMENT

#### PEDAL HEIGHT

Adjust pedal stop bolt at top of pedal assembly until specified pedal height is obtained. Height is measured from floor mat to top of pedal pad.

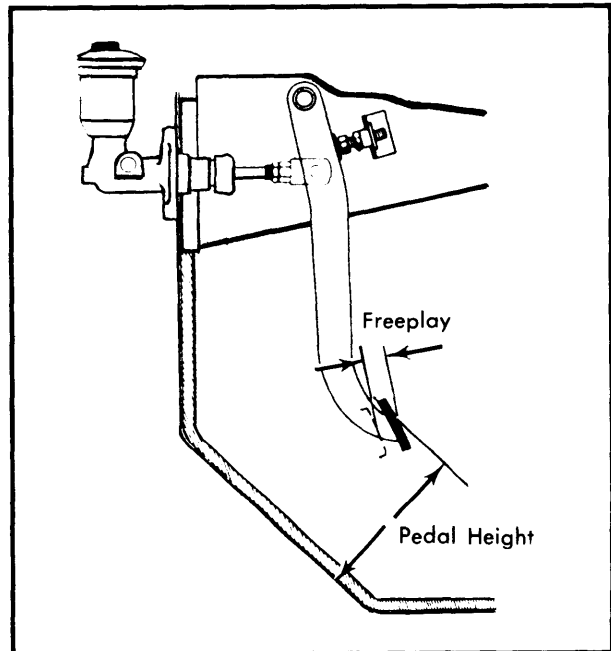

**Fig. 4 Pedal Height and Free Play Measuring Points**

#### Pedal Height Specifications

| Application  | Height                |
|--------------|-----------------------|
| Celica.....  | 6.59" (167 mm)        |
| Corolla..... | 6.65" (169 mm)        |
| Corona.....  | 6.3-6.8" (160-170 mm) |
| Pickup.....  | 6.3" (160 mm)         |

#### MASTER CYLINDER PUSH ROD FREE PLAY

To obtain specified free play between pedal push rod and master cylinder piston, loosen lock nut on push rod and adjust rod until specified free play is obtained.

#### Master Cylinder Push Rod Free Play Specifications

| Application        | Free Play             |
|--------------------|-----------------------|
| Celica.....        | .04-.12" (1.0-3.0 mm) |
| Corona.....        | .04-.28" (1.0-7.0 mm) |
| Hi-Lux Pickup..... | .02-.12" (.5-3.0 mm)  |

# Clutches

## TOYOTA EXCEPT LAND CRUISER (Cont.)

### CLUTCH FORK FREE PLAY

Clutch fork free play determines amount of clearance between clutch release bearing and clutch. To obtain specified free play, loosen lock nut on slave cylinder push rod and screw push rod in or out until specified free play is obtained.

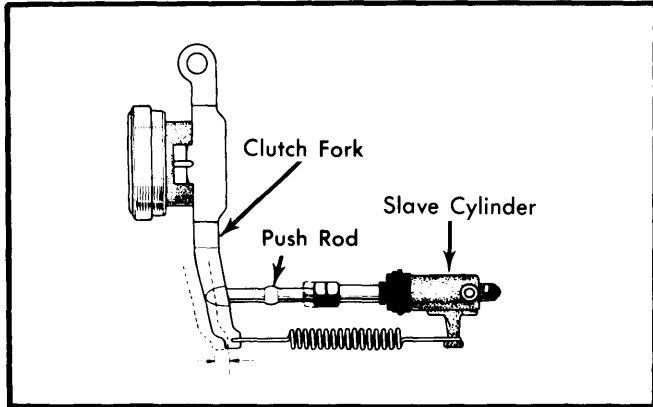

**Fig. 5 Clutch Fork Free Play Measurement Location**

### Clutch Fork Free Play Specifications

| Application     | Free Play             |
|-----------------|-----------------------|
| Corolla.....    | .08-.14" (2.0-3.5 mm) |
| All Others..... | .08-.12" (2.0-3.0 mm) |

### PEDAL FREE PLAY

Pedal free play is total of clutch fork free play and master cylinder push rod free play, and is measured at pedal pad. If other measurements are to specification, pedal free play should be as specified in table.

### Pedal Free Play Specifications

| Application          | Free Play            |
|----------------------|----------------------|
| Celica, Corolla..... | .79-1.58" (20-40 mm) |
| Corona.....          | .79-1.18" (20-30 mm) |
| Pickup.....          | 1.0-2.0" (25-50 mm)  |

### HYDRAULIC SYSTEM BLEEDING

- 1) Raise vehicle and support with safety stands. Make sure clutch master cylinder reservoir is full of fluid. Remove bleeder screw cap and loosen bleeder screw. Place a finger on vent hole of bleeder screw and push clutch pedal to bottom of stroke three or four times.
- 2) With pedal fully depressed, remove finger and allow air to vent out. Repeat procedure three or four times or until pressure is felt. Install a flexible hose on bleeder screw and insert free end into a container partially full of brake fluid.
- 3) Push pedal to bottom of stroke, loosen bleeder screw, and allow fluid to bleed into container. Tighten bleeder screw and release clutch pedal. Repeat procedure until air bubbles are no longer seen in container, then close screw on a down stroke of pedal. Check system for leaks and fill master cylinder.

### TORQUE SPECIFICATIONS

| Application                     | Ft. Lbs. ( mkg) |
|---------------------------------|-----------------|
| Clutch Housing-to-Engine        |                 |
| Corolla, Pickup.....            | 36-50 (5.0-7.0) |
| Corona, Celica.....             | 36-58 (5.0-8.0) |
| Master Cylinder Set Screw.....  | 14-22 (2.0-3.0) |
| Pressure Plate-to-Flywheel..... | 11-16 (1.5-2.2) |