

PEUGEOT

504
604

DESCRIPTION

Clutch is a dry, single disc, diaphragm spring type. Clutch actuation is hydraulic, using a firewall mounted master cylinder and a bell housing mounted slave cylinder. A pre-lubricated clutch release bearing is also used. Due to hydraulic system design, no adjustments, with the exception of bleeding hydraulic system, is necessary.

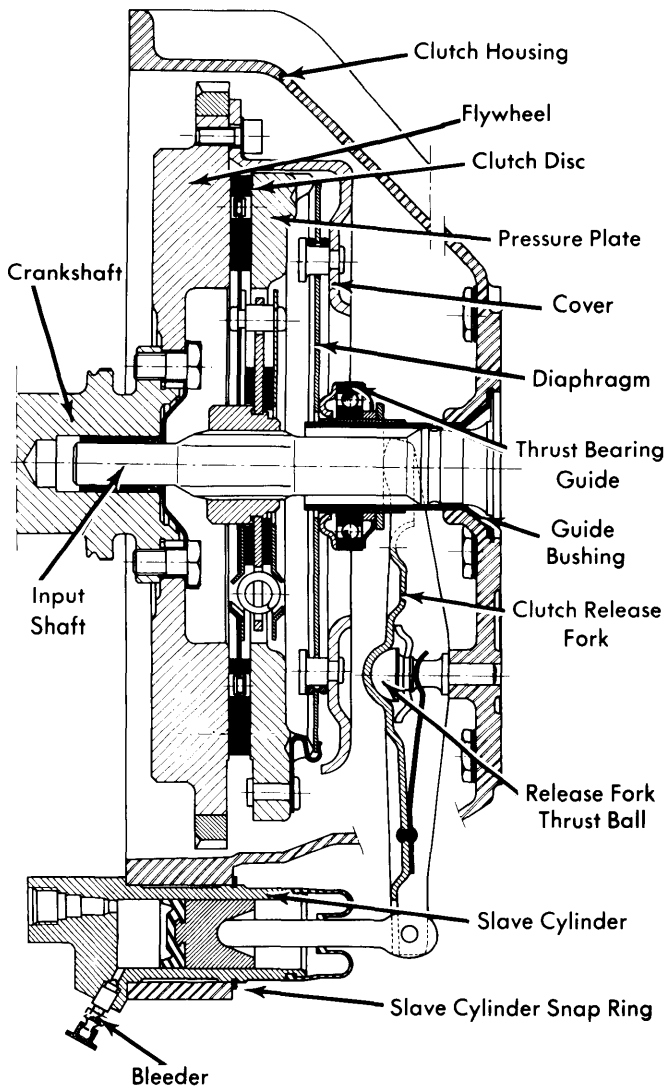

Fig. 1 Sectional View of Clutch Assembly

REMOVAL & INSTALLATION

CLUTCH ASSEMBLY

NOTE — Engine and transmission must be removed as an assembly. See Peugeot article in ENGINE Section.

Removal — 1) Remove engine and transmission assembly.

2) Lower engine and transmission assembly to floor or onto a support.

3) On 604 models, remove 2 bolts mounting starter casing.

4) Remove bolts mounting clutch housing to engine.

5) Mark pressure plate and flywheel for reassembly reference. Remove Allen head bolts and remove clutch assembly.

Installation — Make following notes when installing clutch:

- Place clutch disc on flywheel with flexible hub toward transmission.
- Use a clutch alignment tool to center disc and pressure plate assembly on flywheel. Make sure reference marks are aligned.
- Replace pressure plate mounting bolt washers.
- Lube transmission input splines and clutch release bearing guide with Molykote (or equivalent).

CLUTCH RELEASE BEARING & FORK

1) With engine removed, and working inside clutch housing, remove clutch release bearing from fork by turning it counterclockwise. With slave cylinder removed, pull clutch fork outwards until backing spring is disengaged from ball stud, and remove fork from clutch housing.

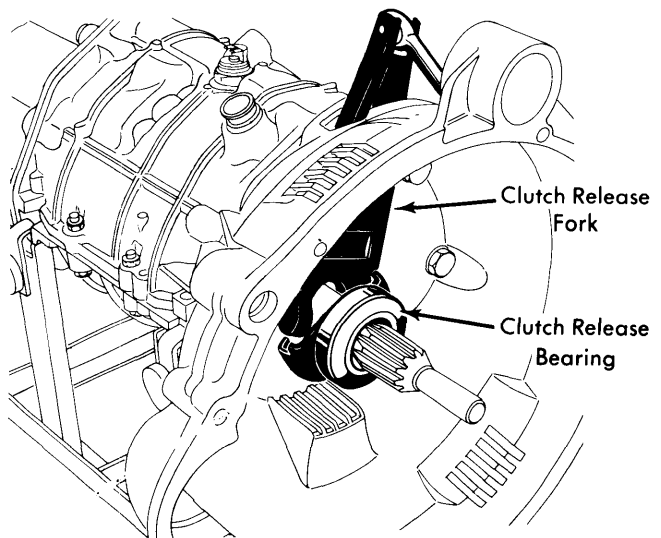

Fig. 2 Installed View of Clutch Release Bearing and Fork

2) Pack rubber cup on ball stud with grease, then slide release fork from inside toward outside of clutch housing. Using a screwdriver, lift fork backing spring, engage fork on ball stud with spring being backed against rubber cup. Install release bearing by engaging onto fork and turning clockwise.

PILOT BUSHING

Bushing is press fit in rear of crankshaft. Bushing must be replaced if excessive clearance with transmission input shaft is evident. Remove and install bushing using suitable pullers and drivers. **NOTE** — Bushing is self-lubricated. Do not wash in any cleaning solution. Lubricate with motor oil when installing.

PEUGEOT (Cont.)

CLUTCH MASTER CYLINDER

Disconnect and plug master cylinder hydraulic lines from fluid reservoir and to slave cylinder. Remove bolts securing master cylinder to pedal assembly and remove master cylinder. To install, reverse removal procedure and bleed hydraulic system.

CLUTCH SLAVE CYLINDER

Disconnect hydraulic line at slave cylinder. Remove snap ring securing cylinder in bell housing, then slide slave cylinder from bell housing mounting. To install, reverse removal procedure and bleed hydraulic system.

ADJUSTMENT

HYDRAULIC SYSTEM BLEEDING

- 1) Attach a suitable adapter (0.0204) to bleeder plug on slave cylinder. Attach a suitable pressure bleeder (ARC 50) to adapter.
- 2) Adjust pressure of bleeder to approximately 25.6 psi. Open bleeder screw on slave cylinder and check fluid level in master cylinder. Close bleeder screw when fluid reaches specified level.