

MERCEDES-BENZ

240D

DESCRIPTION

Dry single disc type clutch uses a diaphragm spring type pressure plate. Clutch actuation is hydraulic, using a clutch pedal mounted master cylinder and a clutch housing mounted slave cylinder. A pedal mounted over-center spring assists in clutch pedal actuation. A sealed prelubricated clutch release bearing is also used.

REMOVAL & INSTALLATION

Removal — 1) Disconnect battery ground cable. Remove rear crossmember, after supporting transmission on a suitable jack or stand. Remove exhaust pipe and supporting bracket. Loosen propeller shaft center bearing, remove propeller shaft-to-transmission bolts. Push propeller shaft towards the rear.

2) Remove tachometer drive from rear of transmission. Remove clutch slave cylinder and pull towards the rear with lines connected, until rod is released from clutch housing. Remove shift linkage from transmission shift levers. Remove starter.

3) Remove transmission-to-intermediate flange attaching bolts (removing two upper bolts last). Pull transmission out horizontally, until input shaft is clear of clutch. Then remove in a downward direction.

4) Loosen pressure plate attaching bolts 1 to 1½ turns at a time until tension is released, then remove all bolts, pressure plate and clutch disc.

Installation — 1) To install, center clutch disc on flywheel using an aligning tool and install pressure plate. Tighten bolts 1 to 1½ turns at a time until tight.

CAUTION — During installation, make sure that clutch is fully pulled into recess in flywheel.

2) To complete installation, reverse removal procedure. Bleed slave cylinder and check hydraulic fluid level. Check clutch adjustment and shift linkage adjustment.

RELEASE BEARING & LEVER

1) Remove release bearing from bearing tube on front transmission cover. Move release lever down and to the left, and pull from ball pin on clutch housing.

2) To install, apply a suitable lubricant to all bearing and lever contact surfaces, and reverse removal procedure.

CLUTCH MASTER CYLINDER

1) Remove floor mats and lining from driver compartment, and remove cover under instrument panel. Siphon sufficient fluid from fluid reservoir to bring level below minimum mark. Loosen input line by pulling elbow out of rubber clamping ring on master cylinder.

2) Disconnect pressure line from master cylinder and unscrew master cylinder from pedal assembly. Remove master cylinder with connecting hose. Push rod remains on clutch pedal.

3) To install, reverse removal procedure, adjust fluid level in fluid reservoir, adjust master cylinder push rod length, and bleed hydraulic system.

CLUTCH SLAVE CYLINDER

1) Disconnect hydraulic line from slave cylinder, then plug line with a rubber cap to prevent loss of fluid. Remove bolts attaching cylinder to clutch housing, and remove slave cylinder and push rod from housing as an assembly.

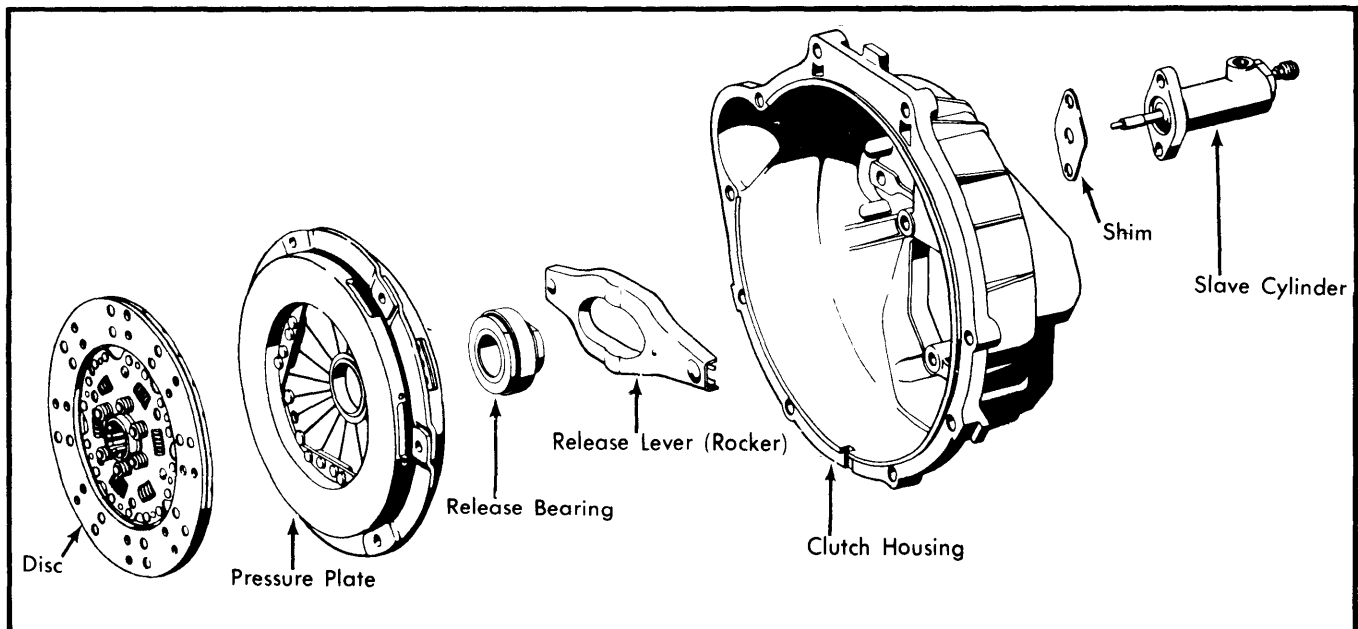

Fig. 1 Mercedes 240D Clutch Components

MERCEDES-BENZ (Cont.)

NOTE — Take care not to lose plastic shim installed between cylinder and housing. Shim is recessed to accommodate inspection gauge.

2) To install, place shim with grooved end against clutch housing and hold in position. Insert slave cylinder with push rod into clutch housing, and install and tighten mounting bolts. Connect hydraulic line to cylinder, and bleed hydraulic system.

NOTE — Wear on clutch disc may only be checked using special inspection gauge inserted in groove of plastic shim. Disc is serviceable if notches on gauge disappear in flange. If notches remain visible, wear limit is exceeded and disc must be replaced. See illustration.

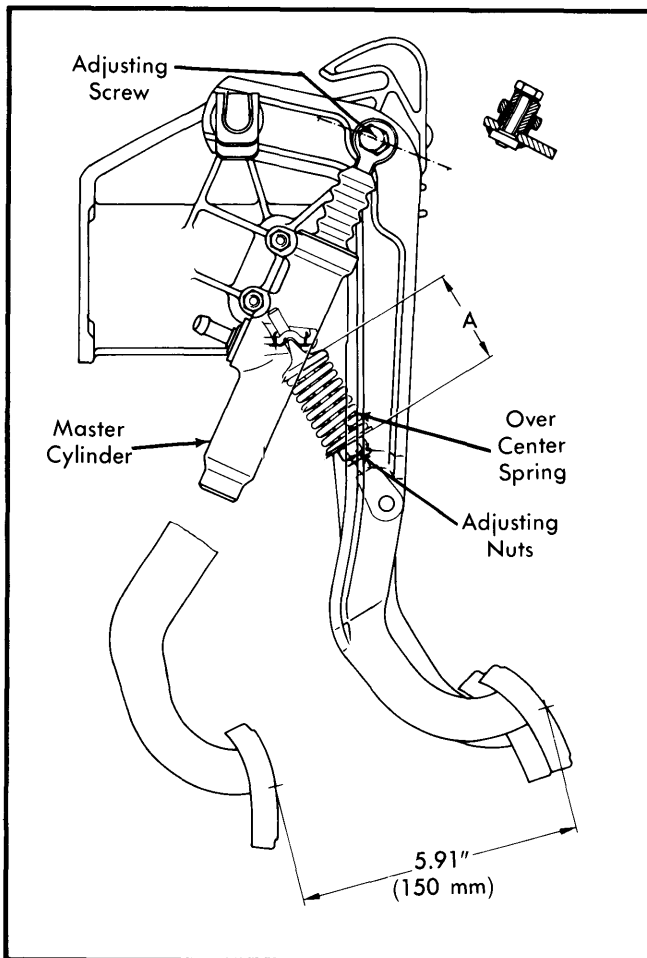

Fig. 2 Clutch Pedal Assembly with Master Cylinder and Over Center Spring

Clearance between master cylinder piston and push rod should be .008" (.2 mm). To adjust, loosen hex nut of eccentric adjusting screw and turn screw until proper clearance is obtained.

OVER CENTER SPRING

Adjust nuts at bottom of over center spring so that spring length measured across retainers is $2.05 \pm .02$ " ($52 \pm .5$ mm). Improper adjustment will result in failure of pedal to return when released or excess pressure required to depress pedal.

HYDRAULIC SYSTEM BLEEDING

With Pressure Bleeder — 1 Connect pressure line of bleeder to opened bleeder screw of slave cylinder. Fluid reservoir of vehicle should be almost empty so that brake fluid can flow from bottom upward through system, allowing air to escape in upward direction.

2) Make sure bleeder is set at lowest possible pressure, and watch reservoir to prevent overflow of fluid. When fluid approaches maximum level in reservoir, remove bleeder and close bleeder screw. Adjust fluid level in reservoir, if necessary, to maximum level in reservoir.

With Assistance of Brake System — 1) Check fluid level in reservoir and make sure it is at maximum level. Place a hose on bleeder screw of right front brake caliper and open screw. Press down on brake pedal until hose is filled with brake fluid and no more air bubbles are showing.

2) Place opposite end of hose on clutch slave cylinder bleeder screw, and open screw. Keep pressure on brake pedal. Close bleeder screw on caliper and release brake pedal. Repeat operation until no more air bubbles appear at fluid reservoir.

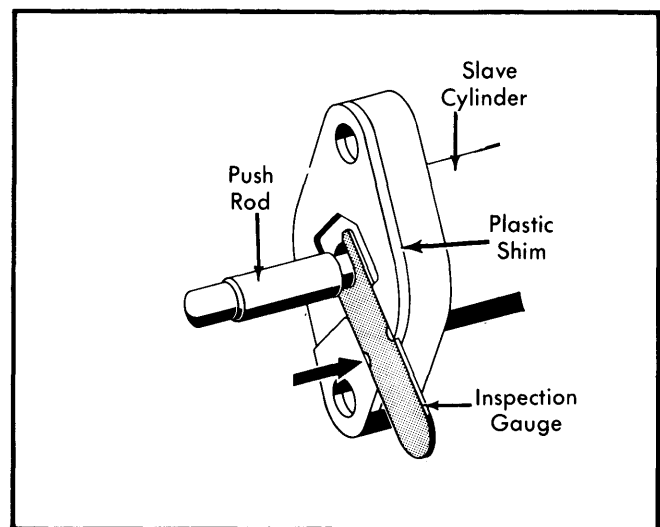

Fig. 3 Checking for Clutch Disc Wear