

AUDI 100LS

100LS

DESCRIPTION

Clutch is of the single plate dry disc type, using a diaphragm type pressure plate and a pre-lubricated clutch release bearing. Clutch is cable actuated.

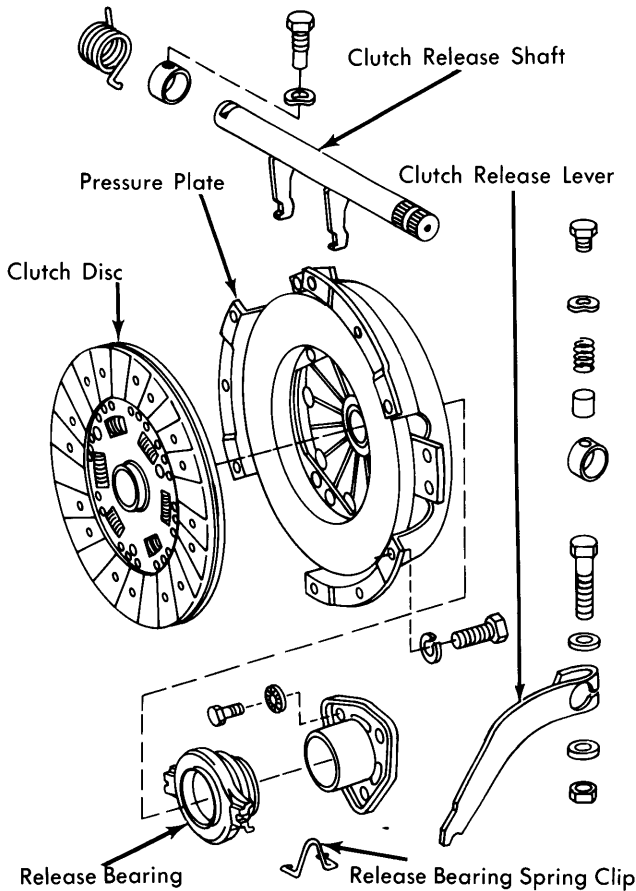

Fig. 1 Exploded View of Audi 100LS Clutch Assembly

REMOVAL & INSTALLATION

CLUTCH ASSEMBLY

1) Remove engine and transmission assembly from vehicle. See *Audi Engine Removal* in **ENGINE** Section. Separate transmission from engine.

2) Mark all parts for reassembly reference, then remove clutch attaching bolts and clutch assembly. To install, reverse

removal procedure and note the following: Use a suitable centering tool (Ku-2) to center clutch disc when installing clutch assembly. Tighten all bolts evenly.

CLUTCH CABLE

1) Remove lower dash panel to gain access to clutch pedal assembly. In engine compartment, loosen adjusting nuts and lift cable out of mounting. Disconnect threaded eyelet from hook at clutch pedal, then remove eyelet and nut from pedal end of cable.

2) Remove cable from engine compartment side. To install, reverse removal procedure and note the following: Position clutch lever so that distance between edge of cable mount and hook portion of lever is 6.3". Adjust clutch pedal free play. See *Pedal Free Play*.

CLUTCH RELEASE BEARING

1) With transmission separated from engine, remove clips securing release bearing to clutch fork. Rotate bearing and check for roughness or noise. **NOTE** — Bearing is pre-lubricated and should not be washed in any cleaning solution.

2) To install, reverse removal procedure, making sure that clips engage cut-outs in back side of release shaft arms. Apply Molykote paste to bearing contact points on clutch fork.

PILOT BEARING

1) Bearing is needle roller type and is pressed into flywheel end of crankshaft. Rotate bearing and check for roughness or noise. If defective, remove using a suitable puller.

2) Lubricate new bearing when driving in. Drive bearing in so that flat side with lettering is facing out.

ADJUSTMENT

PEDAL FREE PLAY

With upper and lower adjusting nuts loose, tighten upper nut until clutch pedal free travel is .6-.8". Tighten lower adjusting nut to secure adjustment, then check operation of clutch assembly.

TIGHTENING SPECIFICATIONS

Application	Ft. Lbs. (mkg)
Clutch Assembly-to-Flywheel	25-28 (3.5-3.9)
Clutch Lever Pinch Bolt	10 (1.4)
Transmission-to-Engine	
12 mm Bolts	54 (7.5)
10 mm Bolts	33 (4.6)
8 mm Bolts	18 (2.5)