

TRIUMPH TR7 4 CYLINDER

ENGINE CODING

ENGINE IDENTIFICATION

Engine number is stamped on cylinder head and may be seen by looking down between intake manifold branches.

CL1234UE

1st & 2nd Digits – Model range.

3rd, 4th, 5th & 6th Digits – Serial number.

7th Digit – "U" denotes USA specification engine.

8th Digit – "E" denotes engine unit.

ENGINE, CYLINDER HEAD & MANIFOLD

ENGINE

1) Disconnect battery and bottom radiator hose, allow coolant to drain. Remove hood, radiator, air cleaner duct and air cleaner hot air hose. Disconnect heater hoses at firewall and brake booster vacuum hose at intake manifold. Disconnect vapor canister hoses from canister, cooling system expansion hose from thermostat housing and vacuum hose from intake manifold to anti-runon valve.

2) Disconnect all electrical leads to engine, fuel line at carburetor(s), choke cable from rear carburetor and throttle cable from throttle linkage. Remove gearshift lever by first removing shift boot, then releasing bayonet cap securing lever to transmission extension. Raise front and rear of vehicle and place on stands. Disconnect propeller shaft from transmission.

3) Disconnect wiring from transmission and remove exhaust downpipe from manifold. Disconnect speedometer cable and remove clutch slave cylinder. Remove complete engine torque strap assembly and disconnect wiring from starter motor. Release wiring harness from clutch housing clips. Remove clutch housing bolts necessary to remove clips and release clutch hydraulic pipe.

4) Remove engine ground strap and hood lock from firewall. Relieve pressure from air conditioning system (if equipped) and disconnect hoses from compressor. Using a lifting sling with a 23" (58.4 cm) leg to rear lift eye and a 18" (45.7 cm) leg to front eye, raise hoist to remove weight of engine.

5) Disconnect right side engine mount and remove five bolts securing rear crossmember to body. Raise rear of vehicle. Hoist engine and remove left side engine mount. Continue raising engine and work it away from vehicle. To install, reverse removal procedure.

INTAKE MANIFOLD

Disconnect battery and drain cooling system, including cylinder block. Remove ducts and air cleaner. Disconnect all hoses, wiring and control cables from manifold and carburetor(s). Remove distributor cap and six manifold bolts. Lift out manifold complete with carburetor(s). To install manifold, reverse removal procedure.

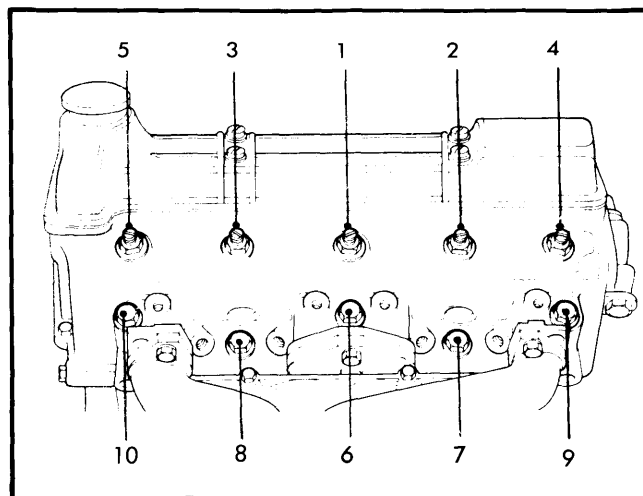

Fig. 1 Cylinder Head Tightening Sequence

CYLINDER HEAD

1) Remove intake manifold as previously described. Remove camshaft cover and semi-circular grommet to gain access to camshaft sprocket nut. Crank engine until camshaft sprocket bottom bolt is accessible and remove bottom bolt. Anchor camshaft sprocket to support bracket. Crank engine so that timing mark on camshaft flange is in line with groove in camshaft front bearing cap and distributor rotor points to manifold rear attachment bolt hole in cylinder head.

2) Unlock and remove top sprocket retaining bolt. Disconnect air hose from air injection check valve and disconnect water pipe from thermostat housing. Disconnect exhaust pipe from manifold. Remove the two cylinder head to timing cover nuts and bolts and loosen cylinder head nuts and bolts in reverse of tightening sequence (See Fig. 1). Remove cylinder head complete with exhaust manifold. To install, reverse removal procedure and tighten bolts to specifications in sequence shown in Fig. 1.

VALVES

VALVE ARRANGEMENT

E-I-I-E-E-I-I-E (front to rear).

VALVE GUIDE SERVICING

1) Inspect valve guide wear by inserting a new valve, lifting it slightly from its seat, and rocking sideways. Movement of valve head across seat should not exceed .020" (.508 mm).

2) If replacement is required, use valve guide removal and installation tool S-60A and adapters to remove and replace valve guide. After guides are installed, ream out guide using a .3130" (7.95 mm) reamer.

VALVE SEAT INSERT SERVICING

1) If valve seat inserts are too badly damaged to be refaced, replace inserts as follows: Machine-out existing inserts taking care not to damage insert bores in cylinder head. Machine in-

TRIUMPH TR7 4 CYLINDER (Cont.)

take valve seat bore to a diameter of 1.665-1.666" (42.29-42.32 mm) or exhaust valve seat bore to a diameter of 1.329-1.330" (33.75-33.78 mm).

2) Heat cylinder head uniformly to a temperature of 356°F (180°C) and immediately install new valve seats squarely into cylinder head. Allow cylinder head to cool and machine valve seats to an inclusive angle of 89°.

VALVE SPRINGS

With cylinder head removed, remove camshaft bearing caps (check that caps are numbered for reassembly in same position) and camshaft. Remove tappets and adjusting shims keeping them in correct order for reassembly. With spring compressor, depress spring and remove valve keepers. Release spring and remove spring and valve collar. To install, reverse removal procedure.

VALVE CLEARANCE ADJUSTMENT

NOTE — This operation may be performed with cylinder head on the bench. When on the bench, turn camshaft using a wrench on hexagon at rear of camshaft.

1) Disconnect battery and remove camshaft cover if cylinder head is installed on engine. Loosen camshaft bearing caps and retighten to specifications. Rotate camshaft or engine and check and record clearance of each valve using a feeler gauge between cam heel and tappet. Maximum clearance exists when cam is vertical to cylinder head.

2) If all clearances are correct, adjustment procedure is completed. If any clearances are incorrect, proceed as follows: Remove camshaft and withdraw each tappet and adjusting shim where clearance requires adjustment, keeping tappets and shims in sequence.

3) Measure shim thickness and add measured valve clearance to arrive at total clearance. Subtract proper valve clearance from total clearance to determine needed shim thickness. Install tappets with correct shims then install camshaft. Recheck valve clearance and install camshaft cover.

Application	Valve Clearance
Intake.....	.008" (.2 mm)
Exhaust.....	.018" (.5 mm)

PISTONS, PINS & RINGS

OIL PAN

1) Disconnect battery and remove fresh air duct and fan shroud. Raise vehicle and drain engine oil. Remove two bolts securing coupling plate on bottom of oil pan to clutch housing. Remove engine torque strap assembly. Support front of engine using hoist or jack. **NOTE** — A bracket, made of angle iron, may be fabricated to bolt into lower timing cover bolt holes. Engine may then be supported by a jack via the fabricated bracket.

2) Remove two engine right side mounting bolts, then remove left side engine mounting to sub-frame nut. Remove oil pan nuts and bolts. Raise engine sufficiently to enable oil pan,

complete with left side engine mounting and cross-member to be removed. To install, reverse removal procedure.

PISTON & ROD ASSEMBLY

Connecting rods and rod caps are numbered. Note positioning and location before disassembly.

Removal — With oil pan and cylinder head removed, unscrew rod nuts and withdraw bearing caps. Place protective sleeves over rod bolts and push out rod and piston. Rotate crankshaft as necessary to gain access to piston and rod assemblies.

Installation — 1) Stager piston ring gaps, lubricate pistons and rings and, using a ring compressor, place piston in cylinder bore ensuring that raised flat portion of piston crown is towards right side of engine.

NOTE — Some pistons may have arrows stamped on both sides of skirt, on the piston pin bore side, to indicate direction of pin off-set. Ensure that these arrows point to right side of engine also. Alternatively some pistons may have an arrow on the crown. These piston assemblies must be installed with arrow pointing to front of engine.

2) Install bearing halves in connecting rod and cap and pull connecting rod onto crankpins. Install bearing caps to their respective numbered connecting rod making sure the bearing keeper recesses in connecting rods and caps are on the same side. Install new nuts and tighten.

PISTON PIN REPLACEMENT

1) Remove circlips from pistons and extract piston pin. Separate piston from connecting rod. Inspect connecting rod bushing for wear and replace if necessary.

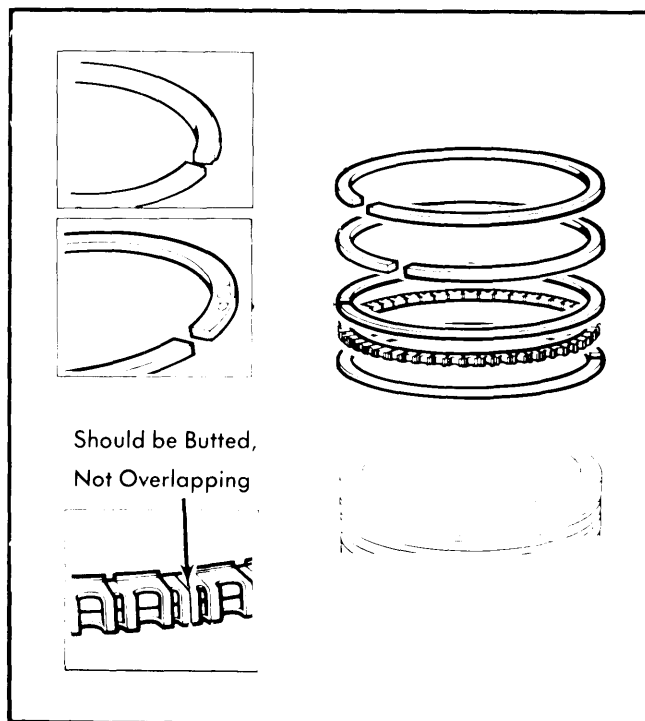

Fig. 2 View Showing Correct Piston Ring Installation

TRIUMPH TR7 4 CYLINDER (Cont.)

2) Using a press, remove worn bushing and install replacement. Ensure oil hole in new bushing is aligned with hole in connecting rod. Ream bushing to fit piston pin. Piston pin diameter is .9374-.9376" (23.810-23.815 mm).

FITTING PISTONS

Inspect and measure cylinder for wear or taper. Measure piston diameter and determine if clearance is correct. Install expanding ring in bottom groove of piston with ends butting but not overlapping. From bottom of piston install bottom rail and from top, upper rail. Install middle ring with word "TOP" facing upward (see Fig. 2). Install upper compression ring and stagger ring gaps.

NOTE— Oversize rings are available in .010 and .020" (.254 and .508 mm) oversizes.

CRANKSHAFT MAIN & CONNECTING ROD BEARINGS

MAIN & CONNECTING ROD BEARINGS

1) Remove engine and separate engine and transmission. Remove clutch, flywheel, engine rear adapter plate, oil pan and dipstick. Remove rear main bearing oil seal, timing chain cover, oil pickup screen and oil slinger. Remove crankshaft sprocket, drive key and shims.

2) Remove connecting rod bearing caps and slightly push up connecting rod assembly but do not dislodge it from cylinder. Remove upper and lower connecting rod bearings and install protectors over connecting rod bolts. Remove timing chain and main bearing caps. Lift out crankshaft. Remove pilot bushing, upper and lower main bearing inserts and thrust washers.

3) Examine all bearing journals and determine if regrinding is necessary. When regrinding crankshaft, do not grind journal diameter to less than specified minimum diameter. Examine each bearing half and replace any damaged bearings. Bearings are available in various oversizes. To install, reverse removal procedure making sure that grooves in thrust washers face outward.

Minimum Crankshaft Regrind Diameters

Application	In. (mm)
Main Journal	2.0860-2.0865 (52.984-52.997)
Connecting Rod	1.7100-1.7105 (43.434-43.447)

CRANKSHAFT END PLAY

Using a feeler gauge or dial indicator, measure crankshaft end play by levering crankshaft back and forth. Value must be within specifications. If not, thrust washers are available in various oversizes.

REAR MAIN BEARING OIL SEAL

1) Disconnect battery and remove transmission, clutch and flywheel. Remove two rear oil pan bolts, loosen two right side

rear and one left side rear oil pan bolts. Remove six bolts securing rear main bearing oil seal housing to crankcase. Press oil seal out of housing.

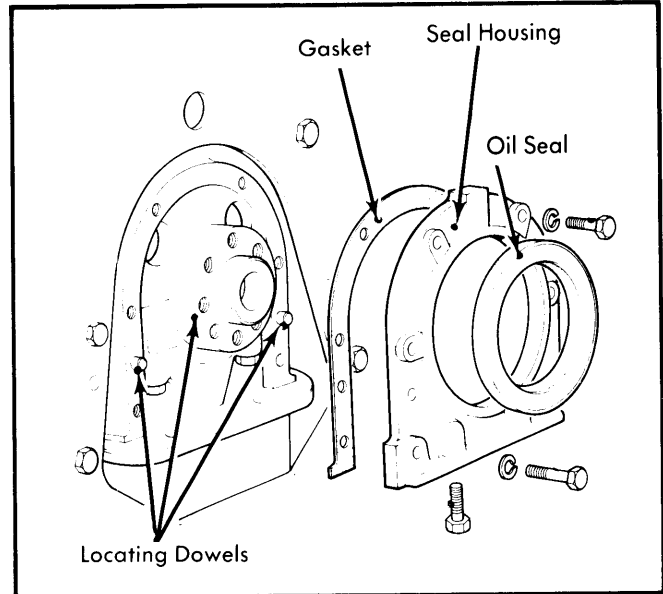

Fig. 3 Exploded View of Rear Main Bearing Oil Seal

2) Lubricate outer diameter of new seal and press it squarely into housing with lip facing crankshaft. Clean gasket area and install new gasket using sealing compound. Lubricate crankshaft and carefully ease seal housing into position on two dowels. Install six retaining bolts noting that two lower bolts are longer. Evenly tighten bolts then install two pan bolts removed previously. Tighten all oil pan bolts and continue assembly in reverse of disassembly.

CAMSHAFT

ENGINE FRONT COVER & OIL SEAL

1) Disconnect battery and remove crankshaft pulleys after first loosening drive belts and removing cooling fan. Remove alternator and mounting brackets. Remove air pump and bracket, and diverter valve and bracket. Remove air conditioning compressor strut (if equipped).

2) Remove two bolts and nuts securing front cover to cylinder head. Remove four bolts securing compressor to engine and three compressor adjusting bolts (if equipped). Remove two front oil pan bolts. Remove front cover center attachment bolt and bottom left side bolt. Remove front cover and gaskets and pry out old seal.

3) Dip new seal in engine oil and with lip facing inward, tap in squarely into front cover until flush with cover. Install front cover on engine in reverse of removal procedure using new gaskets. **NOTE**— Front oil seal may be replaced with front cover installed by first removing crankshaft pulleys and prying out old seal.

TRIUMPH TR7 4 CYLINDER (Cont.)

CAMSHAFT

1) Disconnect battery and remove camshaft cover. Crank engine until camshaft timing mark is 180° from groove in camshaft front bearing cap. Unlock and remove exposed camshaft sprocket retaining bolt. Crank engine so that timing mark on camshaft flange is exactly in line with groove in camshaft front bearing cap. Secure sprocket to support bracket with a suitable nut.

2) Unlock and remove remaining sprocket retaining bolt. Evenly loosen camshaft bearing cap nuts and remove bolts and washers. Check that bearing caps are numbered for identification and remove caps. Remove camshaft. To install, reverse removal procedure making sure timing marks are correctly aligned.

INTERMEDIATE SHAFT

1) Disconnect battery and remove fresh air duct, radiator, air conditioning condenser (if equipped), engine front cover, intake manifold, water pump cover and impeller, fuel pump, and camshaft cover. Crank engine so that timing mark on camshaft flange is in line with groove on front bearing cap. Remove distributor cap and check that rotor points to last intake manifold bolt hole in cylinder head, which indicates number one cylinder TDC.

2) Remove the distributor, hydraulic chain tensioner and adjustable timing chain guide. Remove two Allen head screws and withdraw intermediate shaft keeper plate. Lift timing chain clear of sprocket and pull out intermediate shaft (complete with sprocket). Clamp intermediate shaft in a vise and remove sprocket retaining bolt, tab washer and sprocket. To install, reverse removal procedure, making sure valve timing is set correctly and adjusting timing chain tension.

TIMING CHAIN

1) Remove engine front cover, camshaft cover and distributor cap. Disconnect camshaft sprocket as described under *Camshaft Removal*. Make sure that camshaft timing marks are aligned when engine is TDC, No. 1 cylinder compression stroke. Remove hydraulic chain tensioner and guide plate.

2) Remove locking bolt from adjustable chain guide and common bolt securing adjustable guide and camshaft sprocket support bracket. Remove adjustable guide. Remove bolt securing camshaft support bracket and fixed guide while holding camshaft sprocket. Remove fixed guide and release chain from intermediate shaft and camshaft sprockets. Remove (upward) camshaft sprocket and bracket along with timing chain. To install, reverse removal procedure and check valve and intermediate shaft timing.

3) Set chain tension as follows: Insert a .100" (2.54 mm) feeler gauge between chain slipper and tensioner body (see Fig. 4). Loosen three chain guide retainer bolts and press down on timing chain guide between camshaft and intermediate shaft sprockets until feeler gauge is a sliding fit. Hold guide in this position and tighten adjustable guide bolt first, then two remaining bolts. Remove feeler gauge and continue reassembly.

VALVE TIMING

Crank engine until timing mark on crankshaft pulley coincides with zero mark on front cover scale. At this time, distributor

rotor should point to rear bolt securing intake manifold to cylinder head and timing mark on camshaft flange is in line with groove in camshaft front bearing cap. To adjust timing it is necessary to remove timing chain.

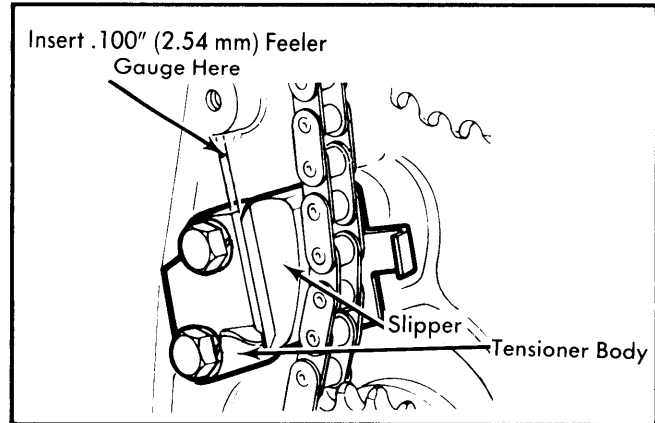

Fig. 4 Adjusting Timing Chain Tension

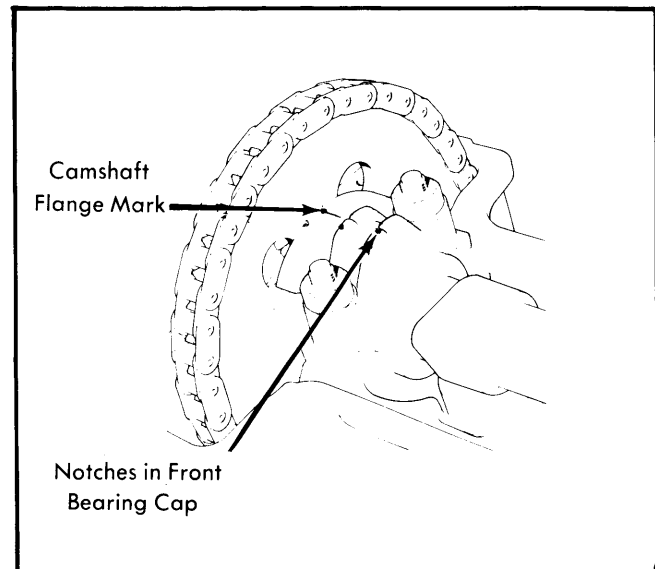

Fig. 5 Alignment of Camshaft Timing

ENGINE OILING

ENGINE OILING SYSTEM

Oil is drawn from engine by a rotor type pump which discharges via a nonadjustable relief valve to a full-flow filter. Cylinder bores, pistons and piston pins are splash lubricated. All other components are oiled through drilled passages.

Crankcase Capacity – 9.5 pts. (including filter).

Oil Filter – Full-flow, paper element type filter.

Oil Pressure Relief Valve – Nonadjustable.

TRIUMPH TR7 4 CYLINDER (Cont.)

OIL PUMP

1) Disconnect battery and raise vehicle. Remove two bolts securing clutch slave cylinder to clutch housing. **NOTE** — Use care when removing slave cylinder that clutch release mechanism doesn't become dislodged. If mechanism does dislodge, transmission will have to be removed to repair it. Remove clutch slave cylinder with hydraulic pipe and move out of way.

2) Remove clutch housing nut and bolt, then remove four oil pump retaining bolts and washers. Remove pump from engine complete with hexagonal drive shaft. Remove "O" ring. To disassemble pump, first remove drive shaft. Remove two screws and lift off pump cover from body. Remove pump rotors and "O" ring. Remove cotter pin from pump body and pull out relief valve plug, spring and valve. Remove "O" ring from relief valve plug.

3) Clean all components and install rotors in pump body, ensuring that chamfered edge of outer rotor is at driving end of rotor pocket. Place a straight edge across pump body and with a feeler gauge check clearance between rotor and straight edge. This clearance should be .004" (.1 mm)

4) With a feeler gauge, check clearance between outer rotor and pump body. Clearance must not exceed .008" (.2 mm). Now check the clearance between the inner and outer rotors with a feeler gauge. This clearance must not exceed .010" (.25 mm).

5) Reassemble and install oil pump in reverse of disassembly, using new "O" rings and making sure large end of relief valve is installed inward so spring will engage small end of valve.

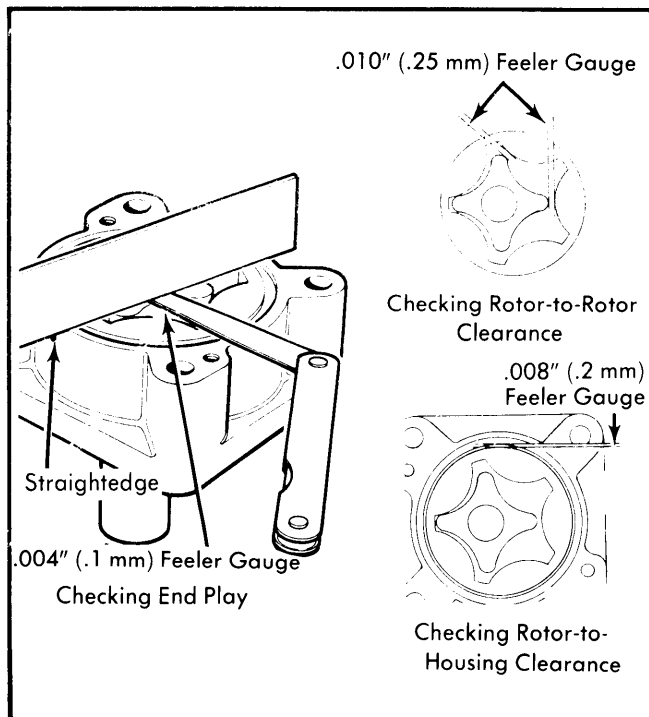

Fig. 6 View Showing Oil Pump Checking Points

ENGINE COOLING

WATER PUMP

1) Disconnect battery and remove intake manifold. Disconnect hoses from water pump cover and remove three bolts securing pump cover to engine. Lift off cover and gaskets. Turn impeller center bolt clockwise until either water pump is released from intermediate shaft drive gear and can be removed, or center bolt is removed. If center bolt comes out, use impact tool (4235A) and adapter (S4235A/10) to remove pump.

2) To overhaul pump, remove center bolt if not previously removed. Use a drift and support tool to remove impeller from shaft. Invert pump assembly (drive gear up) and drift shaft from housing. Remove "O" ring, graphite seal, water slinger, oil seal and circlip from pump shaft. Again invert shaft and drift shaft from bearing. Remove oil slinger. Remove "O" rings from housing.

3) To assemble, reverse disassembly procedure using new seals and "O" rings and noting the following: Make sure oil slinger dish is towards gear. Flat face of oil seal should face bearing. Dish of water slinger should be towards bearing. Install graphite seal with flat face towards bearing.

4) Place pump in housing ensuring that pump and jackshaft gear, mesh correctly and that pump is properly seated. **CAUTION** — Use of force or impact to seat pump will damage pump. Ensure gasket surfaces are clean and temporarily install pump cover. Using feeler gauges, check that gap between pump cover and engine is equal, equalize gap by adjusting bolts.

5) Select water pump cover gaskets to equal the gap noted in step 4) plus .010-.020" (.25-.5 mm) to provide running clearance. Remove pump cover, install selected gaskets, reinstall cover and tighten bolts to specifications. Complete installation in reverse of removal procedure.

Thermostat — Begins to open at about 180°F (82°C).

Cooling System Capacity — 15.5 pts. (including heater).

Radiator Cap — 15 psi (1.05 kg/cm²).

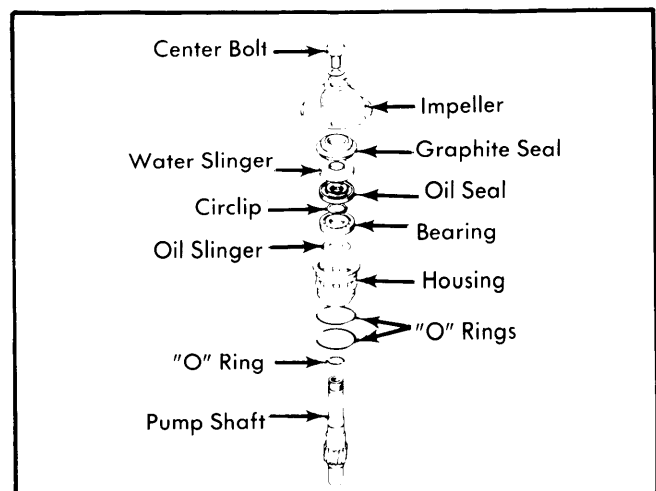

Fig. 7 Exploded View of Water Pump Assembly

Triumph Engines

TR7 4 CYLINDER (Cont.)

ENGINE SPECIFICATIONS

GENERAL SPECIFICATIONS										
Year	Displ.		Carburetor	HP at RPM	Torque (Ft. Lbs. at RPM)	Compr. Ratio	Bore		Stroke	
	cu. ins.	cc					in.	mm	in.	mm
1977	122	1998	⊙2x1-Bbl.	8.0-1	3.56	90.3	3.07	78.0

⊙ — 1x1-Bbl. if equipped with catalytic converter.

VALVES							
Engine & Valve	Head Diam. In. (mm)	Face Angle	Seat Angle	Seat Width In. (mm)	Stem Diameter In. (mm)	Stem Clearance In. (mm)	Valve Lift In. (mm)
1998 cc Intake	1.560 (39.62)	45°	44.5°3103-.3113 (7.881-7.907)	.0017-.0023 (.043-.058)
Exhaust	1.280 (32.51)	45°	44.5°3098-.3106 (7.87-7.89)	.0014-.0030 (.035-.076)

PISTONS, PINS, RINGS						
Engine	PISTONS		PINS		RINGS	
	Clearance In. (mm)	Piston Fit In. (mm)	Rod Fit In. (mm)	Rings	End Gap In. (mm)	Side Clearance In. (mm)
1998 cc	.0005-.0015 (.013-.038)	0-.0004 (0-.010)	.0001-.0006 (.003-.015)	No. 1	.015-.025 (.39-.64)	.0019-.0039 (.048-.099) .0015-.0025 (.038-.064)
				No. 2	.015-.025 (.39-.64)	
				Oil	.015-.055 (.39-1.40)	

CRANKSHAFT MAIN & CONNECTING ROD BEARINGS							
Engine	MAIN BEARINGS				CONNECTING ROD BEARINGS		
	Journal Diam. In. (mm)	Clearance In. (mm)	Thrust Bearing	Crankshaft End Play In. (mm)	Journal Diam. In. (mm)	Clearance In. (mm)	Side Play In. (mm)
1998 cc	2.1260-2.1265 (54.000-54.013)	.0012-.0022 (.030-.055)	Center	.003-.011 (.08-.28)	1.7500-1.7505 (44.450-44.463)	.0008-.0023 (.020-.058)	.006-.013 (.15-.33)

TRIUMPH TR7 4 CYLINDER (Cont.)

ENGINE SPECIFICATIONS (Cont.)

VALVE SPRINGS			
Engine	Free Length In. (mm)	PRESSURE Lbs. @ In. (kg @ mm)	
		Valve Closed	Valve Open
1998 cc	1.60 (40.64)

VALVE TIMING				
Engine	INTAKE		EXHAUST	
	Open (BTDC)	Close (ALDC)	Open (BLDC)	Close (ATDC)
1998 cc	16°	56°	56°	16°

TIGHTENING SPECIFICATIONS

Application	Ft. Lbs. (mkg)
Main Bearing Caps.....	50-65 (6.9-.0)
Camshaft Sprocket Bolt	7-10 (1.0-1.4)
Camshaft Bearing Caps.....	10-14 (1.4-1.9)
Connecting Rod Bolt	40-45 (5.5-6.2)
Crankshaft Pulley Bolt.....	90-120 (12.5-16.5)
Cylinder Head Bolts.....	45-55 (6.2-7.6)
Flywheel-to-Crankshaft.....	40-45 (5.5-6.2)
Jackshaft Sprocket Bolt.....	30-38 (4.1-5.3)
Timing Chain Tensioner-to-Block	6.9 (0.9)
Timing Chain Support Brackets & Guides..	15-20 (2.1-2.8)