

20R 4 CYLINDER

ENGINE CODING

ENGINE IDENTIFICATION

Engine serial number is stamped on left side of cylinder block, behind the alternator. Last group of numerals and letters designates engine type.

Application	Engine Code
2189 cc.....	20R

ENGINE & CYLINDER HEAD

ENGINE

1) Drain coolant and engine oil. Disconnect battery cables. If equipped with auto. trans., drain fluid. Unscrew hinge bolts and remove hood.

2) Remove air cleaner and disconnect heater hoses, fuel lines and all engine wiring. Disconnect flexible cable to carburetor and remove bracket holding cable to cylinder head cover. Disconnect vacuum hoses to emission control and mark them for reinstallation. Make sure to disconnect throttle retard hose connection at base of carburetor.

3) Disconnect vacuum line for brake booster at intake manifold. If equipped with air conditioning, disconnect lines at compressor. Disconnect plug-in for electric clutch.

4) Remove baffle between radiator and front suspension to gain access to lower radiator hose and auto. trans. hoses. Remove radiator and auto. trans. cooler hoses. Remove fan shrouds and grille, radiator baffle, and radiator. Remove condenser lines and condenser.

5) Remove hood lock support. Disconnect clutch hose bracket (if equipped). Remove front engine mount attaching bolts. Engine will rest on mounts.

6) Disconnect exhaust pipe from exhaust manifold and disconnect support bracket from side of transmission. Remove clutch cylinder (if equipped). Remove support bracket for parking brake equalizer.

7) Disconnect speedometer drive cable, transmission linkage and driveshaft. Remove rear engine support after placing jack under engine and removing engine mounting bolts and crossmember. Engine will rest on jack. Remove engine using engine hoist. To install, reverse removal procedure.

CYLINDER HEAD

1) Disconnect battery and exhaust pipe and drain coolant. Remove air cleaner and cover carburetor. Remove all hoses and linkages to intake manifold, carburetor and cylinder head. Remove spark plug wires and distributor. Remove valve cover and set number one piston to TDC on compression stroke.

2) Paint mating marks on camshaft sprocket and timing chain. Remove rubber half circle seal, distributor drive seal and cam

sprocket retaining bolt and remove sprocket from camshaft, allowing sprocket and chain to rest in cylinder head. Remove chain cover bolt, then remove cylinder head bolts in reverse of tightening sequence (See Fig. 1).

3) Pry equally on front and rear of rocker arm assembly and remove same. Lift off cylinder head using care to clear locating dowels. Do not pry between cylinder head and block. To install, reverse removal procedure and note the following: Apply liquid sealer at two front corners of block. Make sure valve timing and clearance is correctly set. Tighten cylinder head bolts in three steps to specified torque and in sequence indicated (See Fig. 1). Set ignition timing statically at 8° BTDC, then reset with timing light.

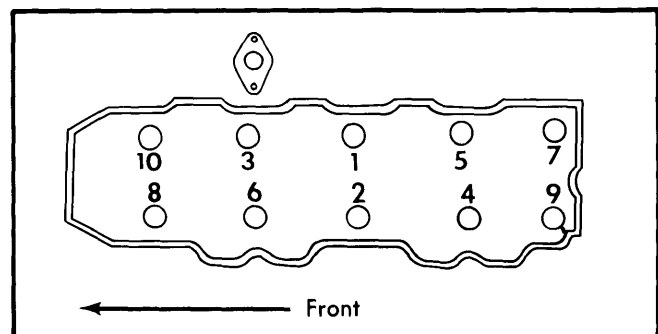

Fig. 1 Cylinder Head Tightening Sequence

VALVES

VALVE ARRANGEMENT

Left Side – All exhaust.

Right Side – All intake.

VALVE GUIDE SERVICING

1) Measure clearance between valve stem and guide. If clearance exceeds specifications, valve guides must be replaced. If valve guide being replaced has a snap ring installed, break guide using brass punch and hammer. Using driver tool (09201-60011), drive old guide down through combustion chamber.

NOTE – Only replacement valve guides have snap rings.

2) Drive in new valve guide from top of head until snap ring contacts cylinder head. Guide should have .75" (19 mm) protrusion above cylinder head. Ream new valve guide to provide proper stem clearance.

VALVE STEM OIL SEALS

1) Using a suitable spring compressor, remove valve keepers. Withdraw spring retainer and springs. Remove valve stem oil seal from end of valve guide.

20R 4 CYLINDER (Cont.)

2) Slide a new oil seal over valve stem, using care not to damage seal as it passes over keeper grooves. Force seal over end of valve guide. Reverse removal procedure for remaining components.

VALVE SPRING INSTALLED HEIGHT

1) With valve spring removed, check length under specified load in a spring tester. Check valve spring free length, if less than specified, replace spring.

2) Check valve spring squareness with a steel square. If spring is out of square more than specified, replace spring.

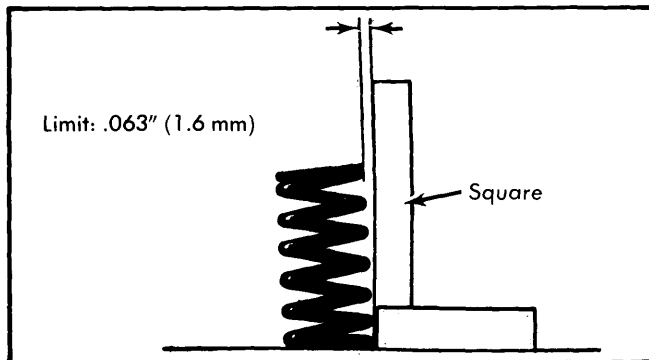

Fig. 2 Checking Valve Spring Squareness

ROCKER ARM ASSEMBLY

If rocker arms appear loose, disassemble rocker arm assembly and measure rocker arm-to-shaft clearance. Clearance should be .0004-.0020" (.01-.05 mm). If clearance is greater than specifications, replace rocker arm and/or shafts. Reassemble in reverse of disassembly noting that all rocker arms are identical but that all rocker stands are different (See Fig. 3).

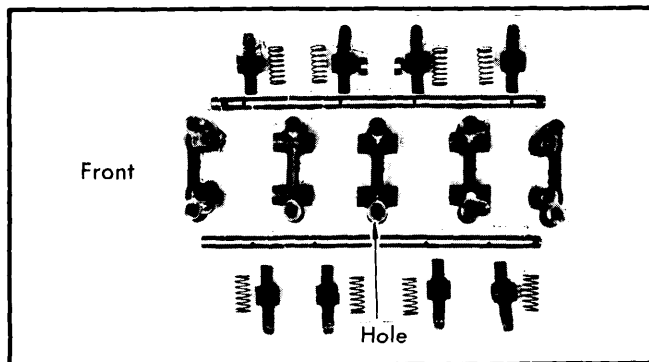

Fig. 3 Disassembled View of Rocker Arm Assembly

VALVE CLEARANCE ADJUSTMENT

Set No. 1 piston to TDC compression stroke. Sprocket timing mark should be slightly left of top. Valve clearance is measured between valve stem and rocker arm. Adjust intake

valves 1 & 2 to .008" (.2 mm) and exhaust valves 1 & 3 to .012" (.3 mm). Rotate crankshaft one complete revolution and align timing marks at pulley. Adjust intake valves 3 & 4 to .008" (.2 mm) and exhaust valves 2 & 4 to .012" (.3 mm).

PISTONS, PINS & RINGS

OIL PAN

NOTE — No on-car removal procedure available.

NOTE — Apply liquid sealer to four corners of oil pan gasket where front cover and rear seal retainer join cylinder block.

PISTON & ROD ASSEMBLY

Removal — Remove connecting rod caps and remove bearings. Push piston and rod assembly up through cylinder head side. Mark all components with cylinder numbers for correct reassembly.

Installation — Apply oil to piston and piston rings. Install compression rings so stamped code on ring faces upward. Position piston ring gaps as shown in Fig. 4. Using suitable ring compressor, install piston and rod assembly in cylinder. Make sure indent on piston faces forward.

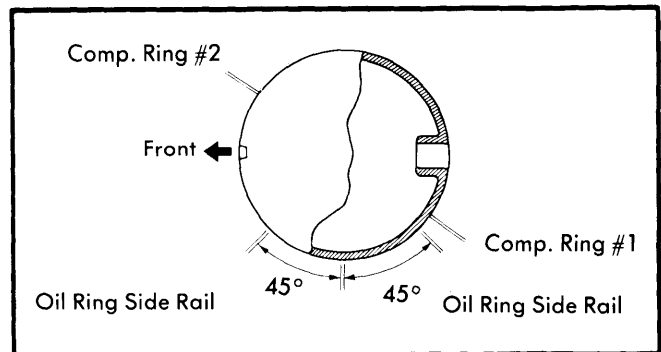

Fig. 4 Correct Piston Ring Gap Arrangement

FITTING PISTONS

1) Measure clearance of piston in cylinder. When measuring piston diameter, measure 90° to pin bore .83" (21 mm) from piston skirt. If clearance exceeds specifications, cylinders must be bored for oversize piston.

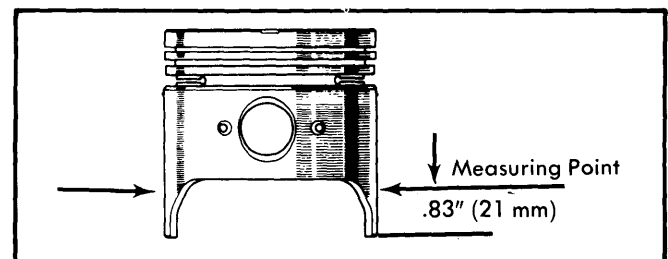

Fig. 5 Piston Diameter Measuring Point

20R 4 CYLINDER (Cont.)

2) Measure piston ring end gaps in cylinder. If cylinder has not been bored, check gap with ring in lowest part of cylinder. Check clearance of piston ring in ring groove.

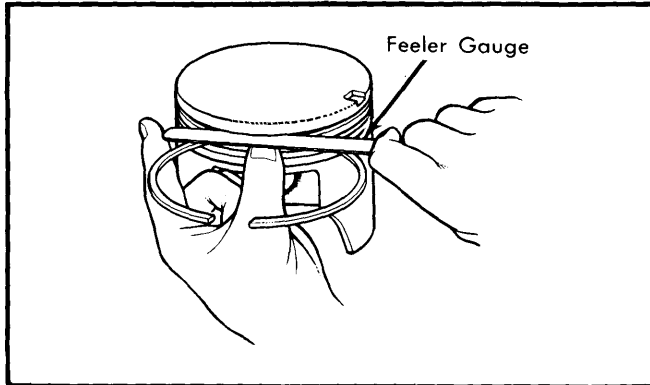

Fig. 6 Measuring Ring Groove Clearance

PISTON PINS

Removal — Heat piston to 176°F (80°C) and push piston pin out of piston and connecting rod. Piston pin should push through connecting rod with thumb pressure when rod is at 68°F (20°C). If pin is too loose in rod, press out bushing from connecting rod using press tool (09222-30010). Install and hone new bushing. **NOTE** — Piston and pin are a matched set.

Installation — Heat piston to 176°F (80°C) and position piston and connecting rod so mark on rod and indent on piston crown face same direction. Push piston pin into piston and rod assembly.

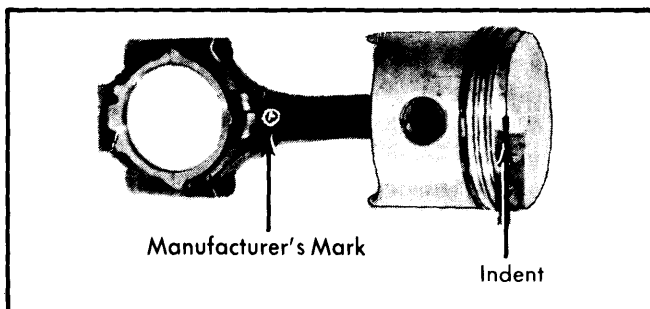

Fig. 7 Correct Alignment of Piston & Rod Assembly

CRANKSHAFT MAIN & CONNECTING ROD BEARINGS

MAIN & CONNECTING ROD BEARINGS

1) Measure crankshaft runout at center bearing journal. If runout exceeds .004" (.1 mm), replace crankshaft. Inspect all journals for wear or scoring. Check for out-of-round or taper. If crankshaft is worn excessively, grind journals for undersize bearings.

2) Measure bearing clearances using Plastigage method. If clearance exceeds specifications, grind journals for undersize bearings. Both main and connecting rod bearings are available .010" (.25 mm) undersize.

THRUST BEARING ALIGNMENT

Check crankshaft thrust clearance at thrust bearing using a feeler gauge. If end play exceeds limit of .012" (.3 mm), replace thrust washers. Thrust washers are available in two oversizes, .005" (.13 mm) and .010" (.25 mm).

REAR MAIN BEARING OIL SEAL

With rear main bearing oil seal retainer removed, pry out old seal. Using suitable tool (09223-41010) drive oil seal in place. After installing new seal, coat seal lip lightly with multi-purpose grease.

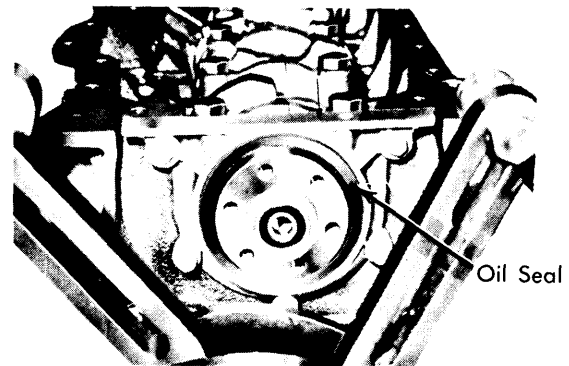

Fig. 8 Installed View of Rear Seal & Retainer

CAMSHAFT

ENGINE FRONT COVER OIL SEAL

With engine front cover removed, pry out old seal toward front side. Using suitable tool (09223-50010), drive seal into place. After installing new seal, coat seal lip lightly with multi-purpose grease.

TIMING CHAIN

Removal — 1) Remove cylinder head and oil pan. Remove radiator, drive belts, air pump and alternator bracket. Remove crankshaft pulley and timing chain cover assembly.

2) Remove chain from damper sprocket and remove cam sprocket and chain. Using puller (09213-36010), remove both oil pump drive and chain sprocket. Check chain, sprockets, tensioner and chain dampers for wear and replace as necessary.

Installation — 1) Turn crankshaft until shaft key is at TDC and slide sprocket over key. Position chain with chromed link over sprocket and aligned with mark on sprocket (See Fig. 9).

20R 4 CYLINDER (Cont.)

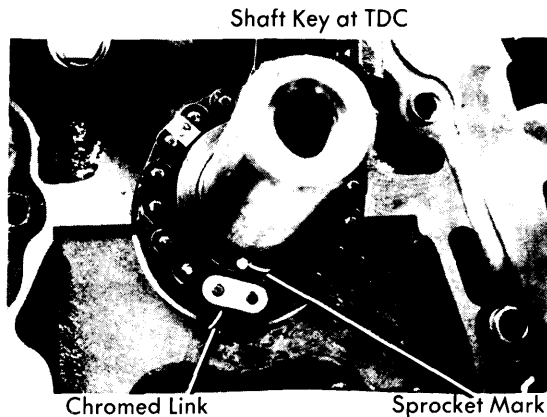

Fig. 9 Aligning Crankshaft Sprocket & Timing Chain

2) Install cam sprocket in chain so that timing mark on sprocket is located between two chromed links on chain (See Fig. 10). Slide oil pump drive spline over crankshaft key. Install new timing cover gasket after first cleaning mounting surface. Turn cam sprocket counterclockwise to remove slack from chain and install timing chain cover.

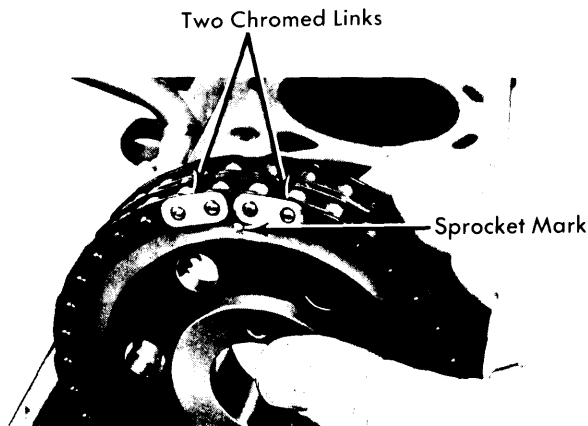

Fig. 10 Aligning Camshaft Sprocket & Timing Chain

3) Continue installation in reverse of removal procedure and set cam timing as follows: With engine at number one cylinder TDC on compression stroke, position camshaft so that dowel on sprocket flange is at 12 o'clock position. Complete reassembly procedure.

CAMSHAFT

With cylinder head and rocker arm assembly removed, remove camshaft bearing caps and lift out camshaft. Camshaft bearing clearance may be checked using Plastigage method. If clearance exceeds specifications, replace cylinder head and/or camshaft. To install, reverse removal procedure. Install bearing caps in numbered order with arrows pointing toward the front. Adjust valve timing.

VALVE TIMING

Valve timing is determined by the relationship between the camshaft and the crankshaft. Turn crankshaft to position No. 1 piston at TDC (align mark on crankshaft with pointer on chain cover). Turn camshaft to locate dowel pin and stamped mark on camshaft at 12 o'clock position. Install timing gear and chain on camshaft. A locating pin may be needed to stretch chain and a hammer may be needed to drive on gear. Tighten timing gear bolts to specifications.

ENGINE OILING

Crankcase Capacity – 3.9 qts. on Celica and Pickup, 4.4 qts. on Corona. Add .9 qts. with filter change on all models.

Pressure Relief Valve – 64 psi (4.5 kg/cm²) operating pressure.

Oil Filter – Full-flow type with paper elements. Located at right side of engine.

ENGINE OILING SYSTEM

Forced feed oiling system utilizing a gear and crescent type oil pump driven from front of crankshaft. Oil from oil pan is pumped through a full flow oil filter and then to oil galleries in cylinder block. Oil is fed to crankshaft bearings, timing chain assembly, camshaft and rocker arm assembly.

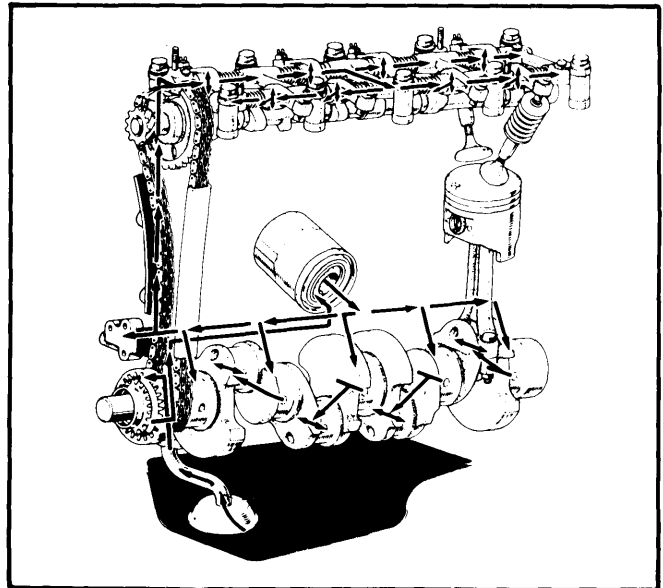

Fig. 11 Engine Oiling System

OIL PUMP

1) Remove oil pan and strainer. Remove drive belts and crankshaft pulley. Unbolt and remove oil pump assembly. Remove oil pump drive spline from crankshaft and "O" ring

2OR 4 CYLINDER (Cont.)

from engine block. Remove relief valve plug, spring and piston from pump body. Remove driven and drive gear from pump body.

2) Inspect pump visually for wear or damage and replace parts as necessary. Place gears in pump body and with feeler gauges measure clearance between driven gear and pump body, driven gear-to-crescent tip clearance, drive gear-to-crescent tip clearance. Measure end clearance by placing straight edge across pump body and measuring clearance between gears and straightedge. To reassemble and install, reverse disassembly and removal procedure.

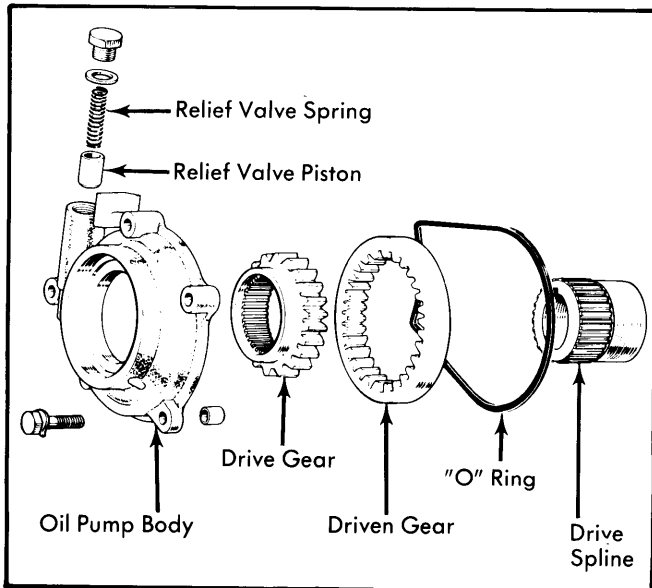

Fig. 12 Exploded View of Oil Pump

Oil Pump Specifications

Application	In. (mm)
Driven Gear-to-Pump Body.....	.0024-.0059 (.06-.15)
Driven Gear-to-Crescent.....	.0059-.0083 (.15-.21)
Drive Gear-to-Crescent.....	.0087-.0098 (.22-.25)
End Clearance.....	.0012-.0034 (.03-.09)

ENGINE COOLING

Thermostat – Starts to open at 187-194°F (86-90°C) and is fully open at 212°F (100°C).

Cooling System Capacity – 8.5 qts. (including heater).

Radiator Cap – 13 psi (.9 kg/cm²).

WATER PUMP

Loosen fan belt and remove fluid coupling assembly, water pump pulley and fan belt. Remove fan from fluid coupling. Remove water pump assembly. To install, reverse removal procedure and use a new gasket.

ENGINE SPECIFICATIONS

GENERAL SPECIFICATIONS										
Year	Displ.		Carburetor	HP at RPM	Torque (Ft. Lbs. at RPM)	Compr. Ratio	Bore		Stroke	
	cu. ins.	cc					in.	mm	in.	mm
1977	133.6	2189	1x2-Bbl.	①96@4800	120@2800	8.4-1	3.48	88.5	3.50	89.0

① – Horsepower is 90@4800 RPM on California models.

PISTONS, PINS, RINGS						
Engine	PISTONS	PINS		RINGS		
	Clearance In. (mm)	Piston Fit In. (mm)	Rod Fit In. (mm)	Rings	End Gap In. (mm)	Side Clearance In. (mm)
2OR	.0012-.0020 (.03-.05)	Press Fit ①	.0002-.0004 (.005-.011) ②	No. 1	.004-.012 (.10-.30)	.008 (.2)
				No. 2	.004-.12 (.10-.30)	.008 (.2)
				Oil

① – Push fit with piston heated to 176°F (80°C).

② – Push fit with piston at room temperature.

Toyota Engines

20R 4 CYLINDER (Cont.)

ENGINE SPECIFICATIONS (Cont.)

CRANKSHAFT MAIN & CONNECTING ROD BEARINGS							
Engine	MAIN BEARINGS				CONNECTING ROD BEARINGS		
	Journal Diam. In. (mm)	Clearance In. (mm)	Thrust Bearing	Crankshaft End Play In. (mm)	Journal Diam. In. (mm)	Clearance In. (mm)	Side Play In. (mm)
20R	2.3614-2.3622 (59.98-60.00)	.0010-.0022 (.025-.055)	Center	.0008-.0079 (.02-.20)	2.0862-2.0866 (52.99-53.00)	.0010-.0022 (.03-.06)	.0063-.0102 (.16-.26)

VALVES							
Engine & Valve	Head Diam. In. (mm)	Face Angle	Seat Angle	Seat Width In. (mm)	Stem Diameter In. (mm)	Stem Clearance In. (mm)	Valve Lift In. (mm)
20R Intake	45°	45°	.047-.063 (1.2-1.6)	.3138-.3144 (7.97-7.99)	.0008-.0024 (.02-.06)
Exhaust	45°	45°	.047-.063 (1.2-1.6)	.3136-.3142 (7.97-7.98)	.0012-.0028 (.03-.07)

VALVE SPRINGS			
Engine	Free Length In. (mm)	PRESSURE Lbs. @ In. (kg @ mm)	
		Valve Closed	Valve Open
20R	1.79 (45.4)	55@1.594 (25.0@40.5)

CAMSHAFT			
Engine	Journal Diam. In. (mm)	Clearance In. (mm)	①Lobe Lift In. (mm)
20R	1.2984-1.2990 (32.98-33.00)	②.0004-.0020 (.01-.05)	Int. 1.680 (42.68) Exh. 1.682 (42.74)

- ① - Total Lobe Height.
- ② - End play is .0031-.0071" (.08-.18 mm)

TIGHTENING SPECIFICATIONS	
Application	Ft. Lbs. (mkg)
Cylinder Head Bolts	52-64 (7.2-8.8)
Main Bearing Cap Bolts	69-83 (9.5-11.5)
Connecting Rod Cap Bolts	39-48 (5.4-6.6)
Camshaft Bearing Cap Bolts	12-17 (1.7-2.3)
Timing Chain Cover	7-12 (1.0-1.6)
Crankshaft Pulley Bolt.....	80-94 (11-13)
Camshaft Sprocket Bolt	51-65 (7.0-9.0)
Intake Manifold	11-15 (1.5-2.1)
Exhaust Manifold.....	29-36 (4.0-5.0)
Oil Pan	2-3 C,3-.4)
Flywheel Bolts	61-69 (8.5-9.5)