

## 2T-C 4 CYLINDER

## ENGINE CODING

## ENGINE IDENTIFICATION

Engine can be identified by first group of numbers and letters in engine serial number. Engine serial number is located on left side of cylinder block behind dipstick. Engine codes are as follows:

## Engine Identification

Application	Code
Corolla.....	2T-C

## ENGINE, CYLINDER HEAD &amp; MANIFOLD

## ENGINE

1) Disconnect battery and drain cooling system. Remove hood support from body, scribe alignment marks on hood and hinges, and remove hood. Remove right headlight door and remove radiator grille, lower grille moulding, radiator baffle (if equipped), hood lock base, and lock brace.

2) On vehicles with automatic transmission, disconnect oil hoses from radiator. On all vehicles, remove radiator hoses and radiator. Disconnect heater hoses from engine and disconnect water temperature gauge wiring.

3) Remove air cleaner, accelerator torque rod, bond cable and clutch hose bracket. Disconnect right front engine mount. Remove distributor wiring, fuel hose, and disconnect exhaust pipe from manifold. Disconnect left front engine mount.

4) Remove shift lever from inside of vehicle and jack up rear end of vehicle and support on stands. Remove exhaust pipe support bracket, propeller shaft, and disconnect speedometer cable. Remove engine rear support member and lightly support transmission with jack and remove engine rear support.

5) With suitable engine hoist, lift up engine, remove jack and move engine to front and remove from vehicle. To install, reverse removal procedure.

## INTAKE MANIFOLD

**Removal** — Drain cooling system, remove air cleaner and carburetor. Disconnect water hose under manifold. Disconnect ventilation hose from manifold, remove manifold bolts and remove manifold.

**Installation** — Clean all mating surfaces and use new gaskets. Reverse removal procedure to complete installation.

## CYLINDER HEAD

1) Drain cooling system and remove air cleaner assembly. Disconnect radiator hoses, heater hoses, and water temperature sending unit wiring.

2) Remove carburetor torque rod and disconnect choke stove pipe and intake pipe. Disconnect PCV valve hose at intake manifold. Disconnect fuel line and vacuum hose at carburetor.

3) Remove clutch flexible hose bracket at cylinder head and jack up vehicle. Remove exhaust pipe clamp No. 1 and disconnect exhaust manifold from cylinder head.

4) Remove cylinder head bolts in sequence, taking two or three steps. Remove rocker arm assembly and push rods. Remove cylinder head with intake manifold attached. To install, reverse removal procedure.

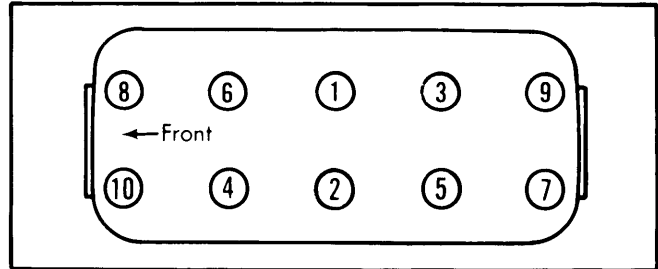

Fig. 1 Cylinder Head Tightening Sequence

## VALVES

## VALVE ARRANGEMENT

**Right Side** — All intake.

**Left Side** — All exhaust.

## VALVE GUIDE SERVICING

**NOTE** — Manufacturer recommends using new valve guides whenever valves are replaced.

1) Measure clearance between valve stem and valve guide bushing. If clearance is greater than .003" (.08 mm) for intake or .004" (.10 mm) for exhaust, replace valve and/or guide bushing.

2) Using suitable tool (brass drift), break off top of valve guide. Heat cylinder head to 176-212°F (80-100°C). Using suitable drift (09201-60010), drive out guide bushing toward combustion chamber.

3) Drive in new guide bushing in same direction it was removed. Valve guide should protrude .67" (17 mm) above cylinder head for both intake and exhaust. If necessary, finish bore of valve guide with reamer, to achieve proper clearance.

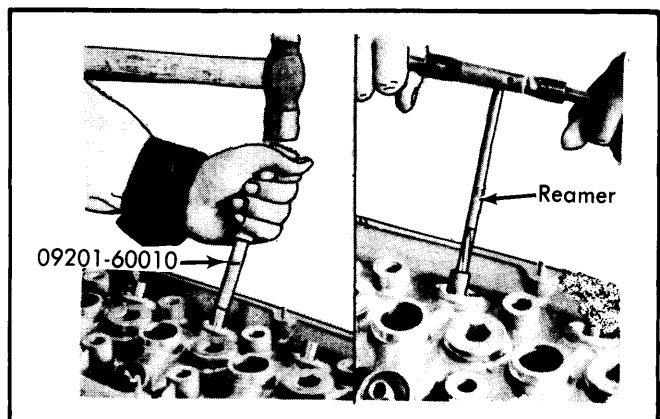

Fig. 2 Removing Valve Guide Bushing and Reaming to Proper Clearance

## 2T-C 4 CYLINDER (Cont.)

### VALVE STEM OIL SEALS

Cup type oil seals are used on all valves. Do not use old seals when valves have been removed. To install, lubricate valve stem and insert in cylinder head. Again lubricate valve stem and carefully push oil seal over valve guide. **NOTE** — Do not push down on top of seal, use pressure on seal sides only.

### VALVE SPRING FREE LENGTH & INSTALLED HEIGHT

Check all valve springs for correct free length, load length and squareness. Spring squareness should be within .075" (1.9 mm). When installed, valve spring height should be 1.484" (37.7 mm).

### ROCKER ARM ASSEMBLY

**NOTE** — There are three kinds of valve rocker shaft supports and two kinds of valve rocker shafts and rocker arms. Do not mix them up.

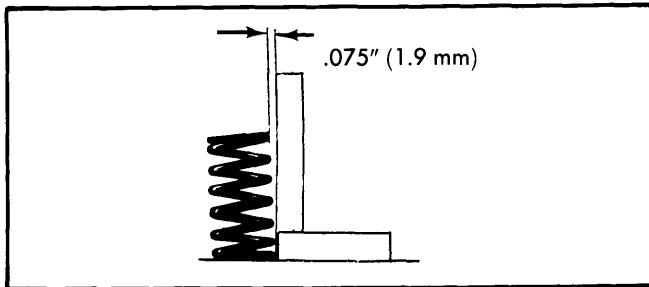

**Fig. 3 Using a Straightedge to Check Valve Spring Squareness Limit**

Remove cylinder head and remove rocker assembly. To disassemble, remove retainer springs, valve rocker support No. 1, compression springs, valve rocker arms for intake valves, valve rocker arms for exhaust valves and rocker supports No. 3 and No. 2. Clearance between rocker arms and shaft should be .001-.002" (.02-.04 mm). Rocker arm shaft for exhaust valves can be identified by oil hole in end of shaft.

**NOTE** — Mark all parts to reassemble in order. Place washer between rocker arm and support number three (center).

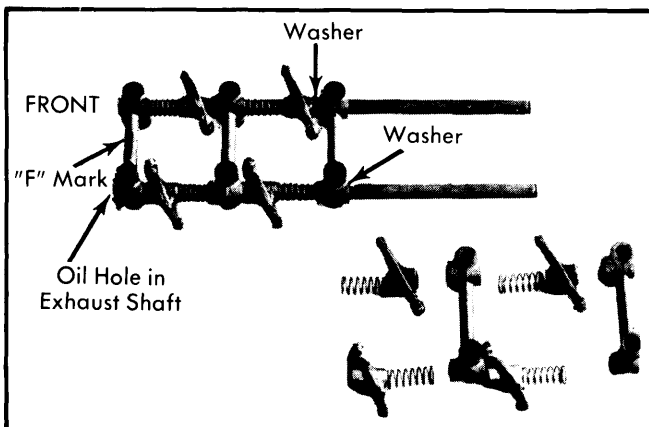

**Fig. 4 Partially Disassembled View of Rocker Arm Assembly**

### VALVE LIFTERS

Inspect lifters and check clearance in bore. If clearance exceeds .004" (.10 mm), select oversize lifter and ream lifter bore to obtain clearance of .001-.002" (.02-.05 mm).

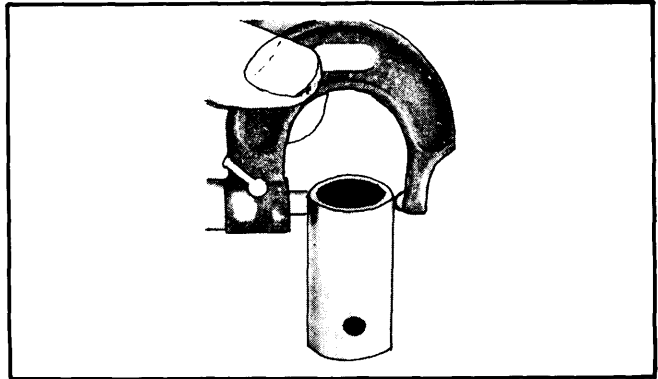

**Fig. 5 Measurement Point for Valve Lifter**

### VALVE CLEARANCE ADJUSTMENT

With number one cylinder at TDC of compression stroke, adjust intake valves of cylinders number one and two, and exhaust valves of cylinders number one and three. Turn crankshaft one complete turn, and adjust intake valves number three and four, and exhaust valves number two and four.

#### Valve Clearance Adjustment

Valve	Hot In. (mm)
Intake .....	.008 (.20)
Exhaust .....	.013 (.33)

## PISTONS, PINS & RINGS

### OIL PAN

1) Disconnect left and right engine front mounts. Jack up vehicle and support on stands. Remove engine front under-cover and right hand stiffener plate. Remove stabilizer bar and oil pan bolts.

2) Place jack under clutch housing and raise slightly taking care not to pull lower radiator hose. Lower oil pan and remove oil pump bolts. Pull oil pan and oil pump forward and outward.

**NOTE** — Apply liquid sealer to four corners of oil pan gasket.

### PISTON & ROD ASSEMBLY

**Removal** — Drain engine coolant system and crankcase. Remove cylinder head, oil pan and oil pump. Remove connecting rod caps and using a wood bar or hammer handle, drive out pistons through top of cylinder block.

## 2T-C 4 CYLINDER (Cont.)

**Installation** — Install piston rings on piston with ring gaps spaced and positioned as shown in Fig. 6. Code letter and number on ring outside surface should face up. Lubricate piston, crankshaft and cylinder. Using suitable piston ring compressor, insert pistons in cylinders, making sure that notch on piston top is toward front of engine. Install connecting rod bearing caps and tighten bolts.

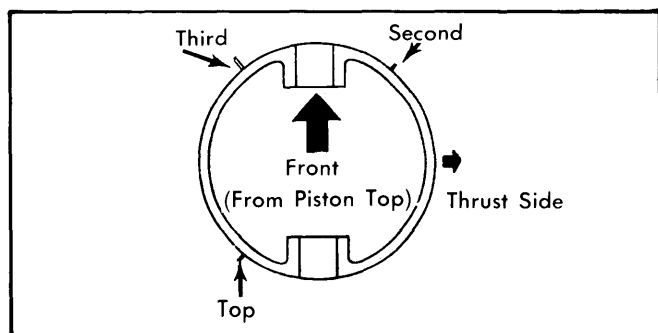

Fig. 6 Installed Position of Piston Rings

**NOTE** — Keep pistons arranged so that they will be replaced in the correct bores.

#### FITTING PISTONS

1) With piston pin removed and pistons at 68°F, measure diameter of pistons  $\frac{1}{16}$ " (11 mm) below lowest ring groove in direction of thrust. Pistons are available .010", .020", .030" and .040" (.25, .50, .75 and 1.00 mm) oversizes.

2) Measure cylinders at top, center and bottom of bore in two directions. If wear exceeds .008" (.20 mm) on any one cylinder, rebore all cylinders for oversize pistons.

3) Insert piston rings into cylinders and measure end gap at lower part of cylinder where wear is smallest. Measure clearance between ring and ring groove.

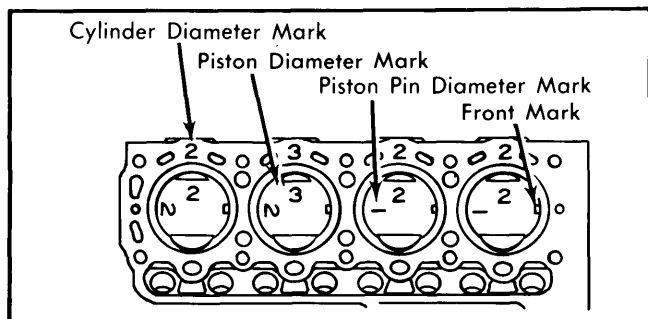

Fig. 7 Diagram Showing Necessary Piston and Cylinder Index Marks

#### PISTON PIN REPLACEMENT

Using suitable tool and press, press out pin from connecting rod and piston assembly. When installing connecting rod to piston, position so that notch at piston top will be on same side as mark on rod center.

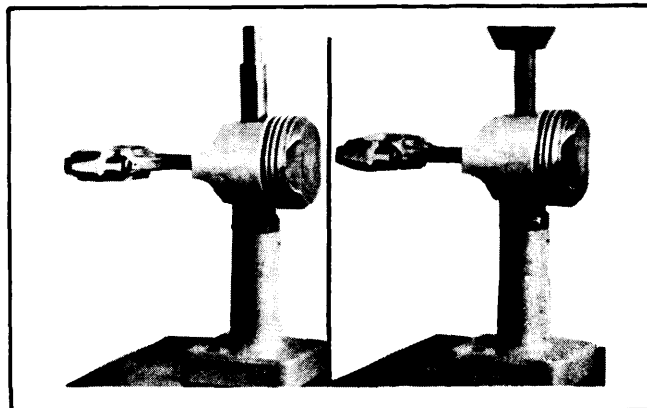

Fig. 8 Using a Press to Remove and Install Piston Pin

### CRANKSHAFT MAIN & CONNECTING ROD BEARINGS

#### MAIN & CONNECTING ROD BEARINGS

1) Using Plastigage method, measure clearance of bearings. Clearance limit is .004" (.10 mm). If proper clearance cannot be obtained with .002" (.05 mm) undersize bearings, grind crankshaft. Bearings are available .002", .010", .020" and .030" (.05, .25, .50, .75 mm) undersizes.

2) Crankshaft bend limit is .001" (.03 mm). Oval and taper wear limit is .0004" (.01 mm). If limits are exceeded, crankshaft must be ground for undersize bearings.

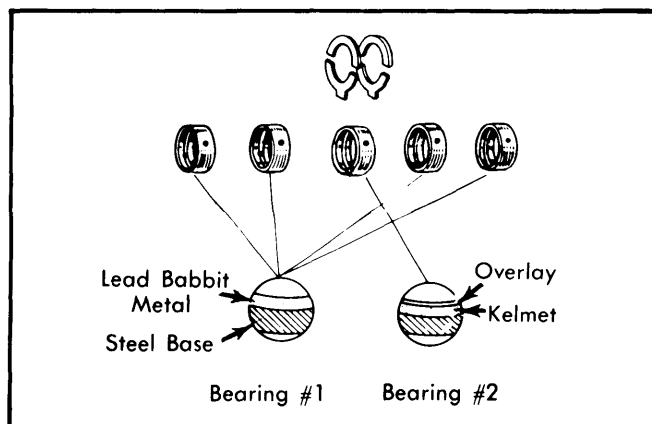

Fig. 9 Crankshaft Bearings

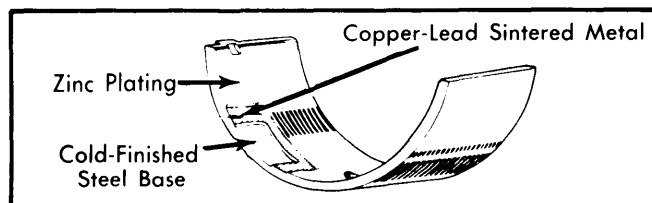

Fig. 10 Connecting Rod Bearings

## 2T-C 4 CYLINDER (Cont.)

### THRUST BEARING ALIGNMENT

Measure crankshaft end play at center bearing. If end play exceeds limit of .012" (.30 mm), install replacement thrust bearings. Bearings are available in standard and oversizes of .005" and .010" (.125 and .25 mm). **NOTE** — Oil groove on bearing faces toward center.

### REAR MAIN BEARING OIL SEAL

Remove oil seal retainer and drive out old oil seal. Apply grease to seal inner lip and take care not to damage this surface. Using suitable tool (09250-10011), drive new seal into place. Replace oil seal retainer with new gasket.

### ENGINE FRONT COVER

1) Jack up vehicle and remove headlamp door and radiator grille. Remove grille lower molding, hood lock base and lock brace. Remove radiator grille and radiator upper baffle. Drain cooling system, disconnect hoses and remove radiator.

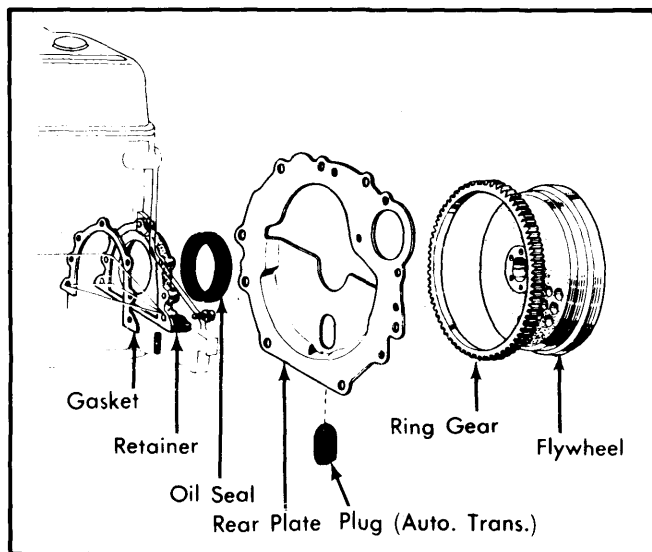

Fig. 11 Oil Seal with Related Components

2) If equipped with Auto. Trans., remove oil cooler hose from radiator. Remove fan belt and water pump assembly. Remove crankshaft pulley. Drain engine oil and remove engine under-cover. Remove right hand stiffener plate, and remove oil pan bolts.

3) Timing chain cover may now be removed. To install, reverse removal procedure and tighten components to specifications.

## CAMSHAFT

### FRONT COVER OIL SEAL

Special Tool 09308-10010 is recommended to pull out oil seal. To install, drive new oil seal into recess in timing cover by using Special Tool 09223-22010.



Fig. 12 Using Special Tool to Install Oil Seal in Front Cover

### TIMING CHAIN AND GEAR INSTALLATION

1) After camshaft has been replaced, rotate crankshaft so that key is pointing up with pistons No. 1 and No. 4 at TDC. Turn camshaft and position key so that it lines up with timing mark in thrust plate.

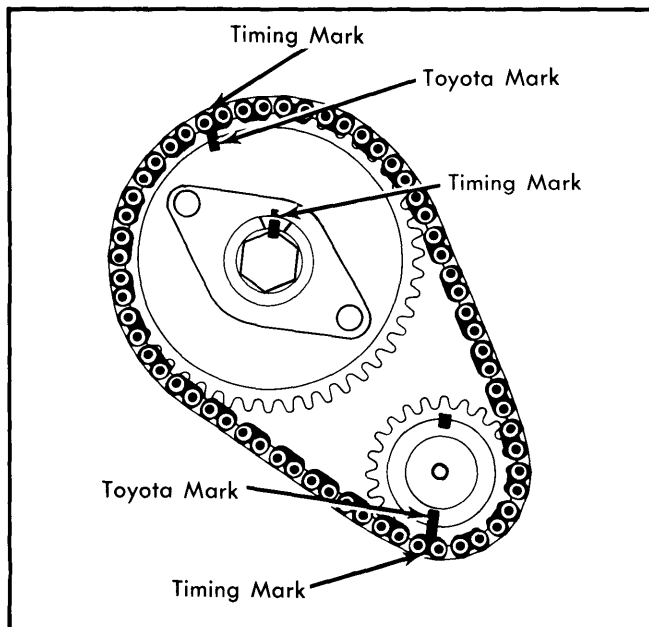

Fig. 13 Timing Chain and Timing Sprocket Marks

2) Assemble crankshaft timing gear and camshaft timing gear to chain so that Toyota marks on each gear line up with chain timing marks. Install gears and chain onto crankshaft and camshaft. Install chain tensioner, chain damper and timing cover.

3) Inspect camshaft for bending and wear. Maximum bend limit is .0012" (.03 mm).

### TIMING CHAIN TENSIONER & DAMPER

1) Inspect surfaces of tensioner plunger and bore of tensioner body. To test clearance, lubricate plunger and insert it into

## 2T-C 4 CYLINDER (Cont.)

plunger body. Cover two oil passages with fingers and pull plunger. Vacuum strong enough to return plunger should be felt.

2) Measure thickness of tensioner head and chain damper wall. Head should be minimum .492" (12.5 mm) and chain damper should be minimum .20" (5.0 mm).

3) To measure chain deflection, pull chain tensioner head with spring scale at 22 lbs. (10 kg). Clearance between tensioner head and body must not exceed .532" (13.5 mm). If limit is exceeded, replace chain, gear or tensioner plunger.

**NOTE**— Chain tensioner must be filled with oil after replacing tensioner or timing chain.

**CAMSHAFT**

1) Remove timing chain cover. See *Timing Chain Cover Removal*. Remove cam timing gear bolt and timing chain tensioner. Remove timing chain and gears, from camshaft and crankshaft, as a unit. Remove cylinder head, distributor and fuel pump.

2) Remove shift lever and support transmission lightly on jack and remove engine rear support member. Then carefully lower jack. Remove camshaft thrust plate and pull out camshaft, being careful not to damage bearings.

**CAMSHAFT BEARINGS**

Using suitable bearing remover tool (09215-25010), pull out bearings one, two and five toward front and bearings three and four toward rear. Using same tool, install new bearings in order one through five, taking care to line up oil holes in bearings with oil holes in block. Bearings are available .005" and .010" (.125 and .250 mm) undersize.

**NOTE**— Apply liquid sealer to plug at rear of block.

**CAMSHAFT END THRUST**

To measure end thrust, install thrust plate and timing gear. Tighten timing gear bolt and use feeler gauge to measure end thrust. Standard clearance is .003-.009" (.07-.22 mm) and limit is .012" (.30 mm). If thrust clearance maximum is exceeded, replace camshaft.

**ENGINE OILING**

**Crankcase Capacity** — 4.6 qts. includes filter.

**Oil Filter** — Full flow type with integral relief valve.

**Normal Oil Pressure** — 28 psi (2 kg/cm<sup>2</sup>) at idle; 43 psi (3 kg/cm<sup>2</sup>) running (minimum values).

**Oil Pressure Regulator Valve** — Begins to open at 51-63 psi (3.6-4.4 kg/cm<sup>2</sup>).

**OIL PUMP**

Oil pan must be removed to gain access to oil pump. If oil pump assembly is tight, tap it out lightly from distributor side. Both drive and driven rotors have punch marks on upper side of rotors, which should be matched when assembling oil pump.

**Oil Pump Specifications**

Application	In. (mm)
Rotor Tip Clearance .....	.002-.006 (.04-.16) Limit .010 (.25)
Rotor Side Clearance .....	.001-.004 (.03-.09) Limit .006 (.15)
Rotor-to-Body Clearance .....	.004-.006 (.10-.16) Limit .010 (.25)

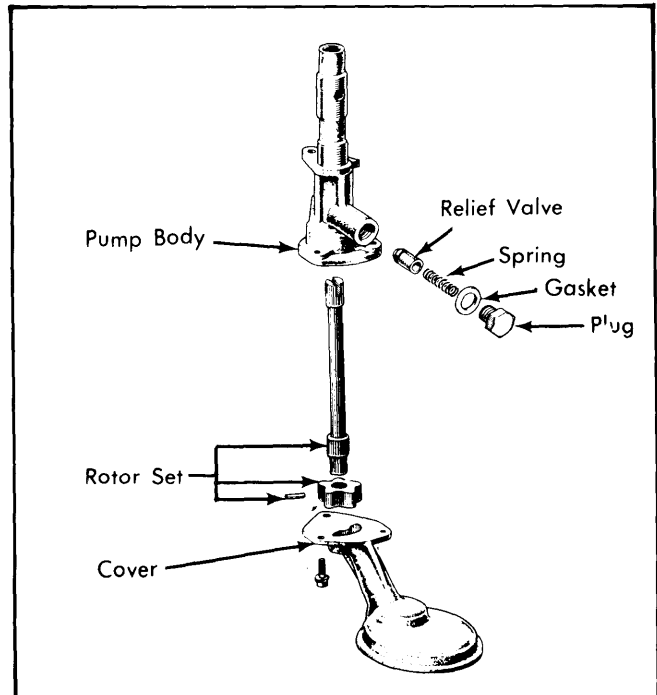

Fig. 14 Exploded View of Oil Pump & Pressure Relief Valve Assembly

**ENGINE COOLING**

**Thermostat** — Wax pellet type thermostat with opening temperature of 187-194°F (80-90°C). Fully opened at 212°F (100°C).

**Coolant Capacity** — Approximately 8 qts.

**WATER PUMP**

Drain cooling system, remove radiator hoses and by-pass and heater hoses. Remove fan belt. Remove attaching bolts and remove water pump. Separate fan and pulley. To install, reverse removal procedure.

**COOLANT DRAINING**

Whenever the coolant is drained the following procedure is mandatory: Fill radiator to top, loosen coolant temperature sending unit, and back it out enough to bleed trapped air from cylinder head. When all air has been vented, coolant level in radiator will drop. Be sure that engine is not started during this procedure. Check coolant level.

# Toyota Engines

5-297

## 2T-C 4 CYLINDER (Cont.)

### ENGINE SPECIFICATIONS

GENERAL SPECIFICATIONS										
Year	Displ.		Carburetor	HP at RPM	Torque (Ft. Lbs. at RPM)	Compr. Ratio	Bore		Stroke	
	cu. ins.	cc					in.	mm	in.	mm
1977	96.9	1588	1x2-Bbl.	88@6000	91@3800	8.5:1	3.35	85	2.76	70

VALVES							
Engine & Valve	Head Diam. In. (mm)	Face Angle	Seat Angle	Seat Width In. (mm)	Stem Diameter In. (mm)	Stem Clearance In. (mm)	Valve Lift In. (mm)
2T-C Intake	1.61 (41)	45°	45°	.055 (1.4)	.3137-.3143 (7.97-7.99)	.0010-.0024 (.025-.061)	.....
Exhaust	1.42 (36)	45°	45°	.055 (1.4)	.3135-.3141 (7.96-7.98)	.0012-.0026 (.030-.066)	.....

PISTONS, PINS, RINGS						
Engine	PISTONS	PINS		RINGS		
	Clearance In. (mm)	Piston Fit In. (mm)	Rod Fit In. (mm)	Rings	End Gap In. (mm)	Side Clearance In. (mm)
2T-C	.002-.003 (.05-.07)	Press Fit	Press Fit	No. 1	.008-.016 (.20-.40)	.0008-.0024 (.02-.06)
				No. 2	.004-.012 (.10-.30)	.002-.0022 (.05-.055)
				Oil	.008-.020 (.20-.51)	.....

CRANKSHAFT MAIN & CONNECTING ROD BEARINGS							
Engine	MAIN BEARINGS				CONNECTING ROD BEARINGS		
	Journal Diam. In. (mm)	Clearance In. (mm)	Thrust Bearing	Crankshaft End Play In. (mm)	Journal Diam. In. (mm)	Clearance In. (mm)	Side Play In. (mm)
2T-C	2.282-2.284 (57.976-58.000)	.0009-.0019 (.024-.048)	Center	.003-.007 (.07-.18)	1.8888-1.8898 (47.976-48.000)	.0009-.0019 (.024-.048)	.006-.010 (.16-.26)

# Toyota Engines

## 2T-C 4 CYLINDER (Cont.)

### ENGINE SPECIFICATIONS (Cont.)

TIGHTENING SPECIFICATIONS	
Application	Ft. Lbs. (mkg)
Cylinder Head Bolts .....	61.5-68.7 (8.5-9.5)
Rocker Arm Support .....	52-64 (7.2-8.8)
Manifold Bolts .....	7-12 (1.0-2.0)
Camshaft Thrust Plate .....	7-12 (1.0-2.0)
Timing Gear Bolt .....	51-80 (7.0-11.0)
Crankshaft Pulley Bolt .....	29-43 (4.0-6.0)
Connecting Rod Cap Bolts .....	29-36 (4.0-5.0)
Main Bearing Cap Bolts .....	52-64 (7.2-8.8)
Flywheel Bolts .....	42-43 (5.8-6.0)
Oil Pan Bolts .....	2-3 (.3-.4)
Radiator Thermo Switch .....	22-29 (3.0-4.0)

CAMSHAFT			
Engine	Journal Diam. In. (mm)	Clearance In. (mm)	Lobe Lift In. (mm)
2T-C			Int. .252 (6.39)
No. 1	1.829-1.830 (46.46-46.48)	.0010-.0026 (.025-.066)	
No. 2	1.819-1.820 (46.21-46.23)		Exh. .258 (6.55)
No. 3	1.809-1.810 (45.96-45.98)		
No. 4	1.800-1.801 (45.71-45.73)		
No. 5	1.790-1.791 (45.46-45.48)		

VALVE SPRINGS			
Engine	Free Length In. (mm)	PRESSURE (LBS.) Lbs. @ In. (kg @ mm)	
		Valve Closed	Valve Open
2T-C	1.657 (42.1)	58.4 @ 1.484 (26.3 @ 37.7)	.....