

924 4 CYLINDER

ENGINE CODING

ENGINE IDENTIFICATION

Engine number is located on left side of crankcase next to the clutch housing. Engine number is coded as follows:

Engine Code Number

Application	1977 Codes	1977 1/2 Codes
924 Federal	XH	XG
924 Calif.	XF	XE

ENGINE, CYLINDER HEAD

ENGINE

Removal - 1) Disconnect battery cable and remove engine protection plate. Scribe hood at hinges and remove hood. Drain cooling system, remove hoses and expansion tank. Remove fan motors with shroud and alternator cooling hose.

NOTE - Remove A/C compressor without disconnecting hoses and lay aside.

2) Disconnect all wiring, hoses, lines, linkage and brackets from engine. Disconnect exhaust pipe at manifold. Support drive line at front brace with wooden block. See Fig. 1.

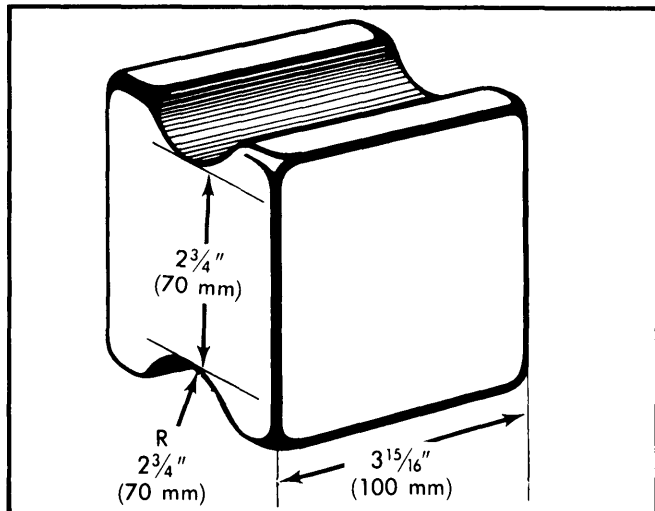

Fig. 1 Drive Line Support Block

3) Disconnect universal joint at steering rack. Disconnect stabilizer bar at frame on both sides and remove crossmember. Attach hoist and lift engine slightly. Remove bellhousing bolts and engine mounts. On vehicles equipped with automatic transmissions, remove bolts from metal/rubber damper. Lift engine carefully and turn at same time.

Installation - To install engine, reverse removal procedure.

CYLINDER HEAD

Removal & Installation - 1) Disconnect battery ground strap and drain cooling system. Remove hoses and wiring con-

ected to cylinder head. Remove exhaust pipe at manifold and remove camshaft timing belt and "V" belt.

2) Remove cylinder head cover and head bolts in sequence. To install, reverse removal procedures.

NOTE - Retorque head bolts after 1000 miles (1600 km). Loosen bolts in sequence and retorque to 86 ft. lbs. (12 mkg).

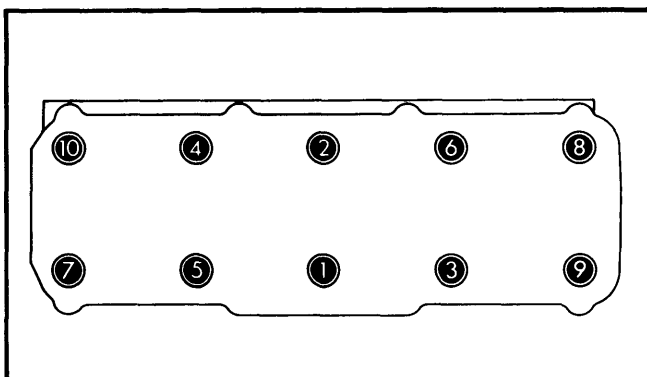

Fig. 2 Cylinder Head Tightening Sequence

VALVES

VALVE ARRANGEMENT

I-E-I-E-I-E-I-E (Front to rear).

VALVE GUIDE SERVICING

NOTE - At present, there is no procedure for valve guide replacement.

Measure amount of clearance between valve and valve guide (rock). If wear is excessive, head must be replaced. Intake valve guide maximum clearance is .032" (0.8 mm). Exhaust valve guide maximum clearance is .039" (1.0 mm).

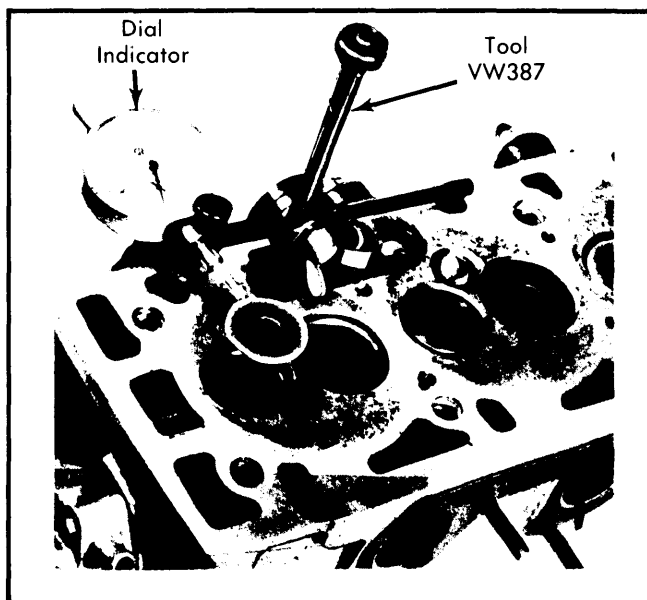

Fig. 3 Measuring Valve Guide Clearance

924 4 CYLINDER (Cont.)

VALVE STEM OIL SEALS

NOTE — Valve stem oil seal may be replaced with cylinder head installed.

Remove spark plug on cylinder being serviced, install air hose and adapter to maintain constant pressure in cylinder. Remove camshaft, tappets, valve stem keepers and valve spring. Remove oil seal and discard. To install, reverse removal procedures while noting the following; Be sure plastic sleeve is installed prior to seal installation. Place sleeve on valve stem, lubricate seal and install onto valve stem.

MECHANICAL VALVE LIFTERS

With camshaft removed, lift out tappet and inspect for wear or damage. Oil tappets lightly and replace in original position.

VALVE CLEARANCE ADJUSTMENT

1) Remove cylinder head cover and turn crankshaft until cam lobes of cylinder to be adjusted are pointing upward. Check valve clearance with feeler gauge between tappet and lobe.

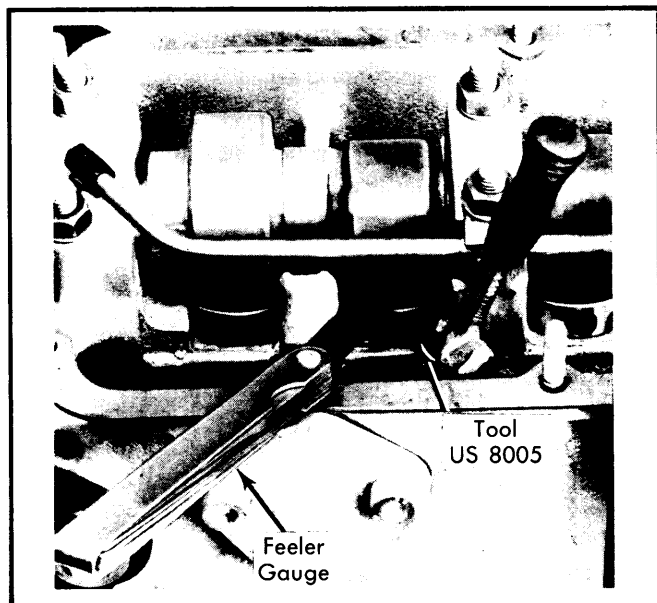

Fig. 4 Valve Adjustment

2) Basic valve clearance with engine cold (when reconditioning engine) is .004" (.10 mm) for intake valve and .016" (.40 mm) for exhaust valve. Valve clearance should be checked with engine warmed to 176°F (80°C) oil temperature. Intake valve clearance is .008" (.20 mm) and exhaust clearance is .018" (.45 mm).

3) Adjust clearance by turning screw mounted in tappet with adjusting tool US 8005. Adjustment must be in complete turns only. One turn of screw changes clearance by .002" (.05 mm). After adjusting valve, be sure edge of tappet is in line with green area of tool.

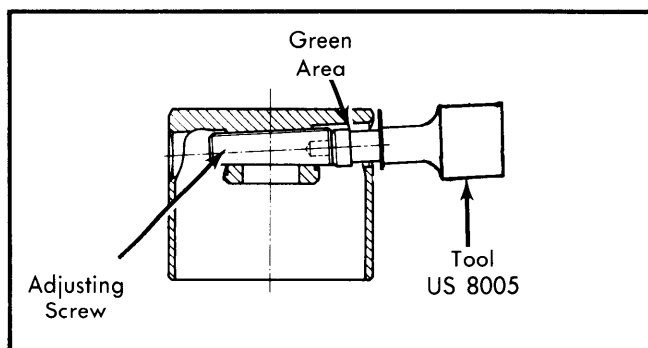

Fig. 5 Valve Lifter Adjustment

PISTONS, PINS & RINGS

OIL PAN

Drain engine oil and loosen left engine mount slightly. Disconnect steering at crossmember and remove crossmember. Remove oil pan bolts and lower oil pan. To install, reverse removal procedure and tighten pan bolts to specifications.

PISTONS & ROD ASSEMBLY

1) Before removing connecting rods, mark rod and cap for installation in original position. Remove rod caps and carefully push piston and rod assembly out top of block.

2) On reassembly of piston and rod assembly, cast bosses on rod and cap must face pulley end of engine. Code numbers must be on same side. Using a suitable ring compressor, install piston and rod assembly with arrow on crown of piston facing front of engine.

FITTING PISTONS

1) Measure cylinder bore .39" (9.9 mm) down from top and up same distance from bottom, also in the center. Take two measurements, one in line with crankshaft and again 90° to crankshaft.

2) Measure piston .63" (16 mm) from bottom of skirt 90° to pin bore. Combine measurements with those taken from cylinder bore. If piston-to-cylinder measurement exceeds .0016" (.04 mm), oversized pistons must be installed.

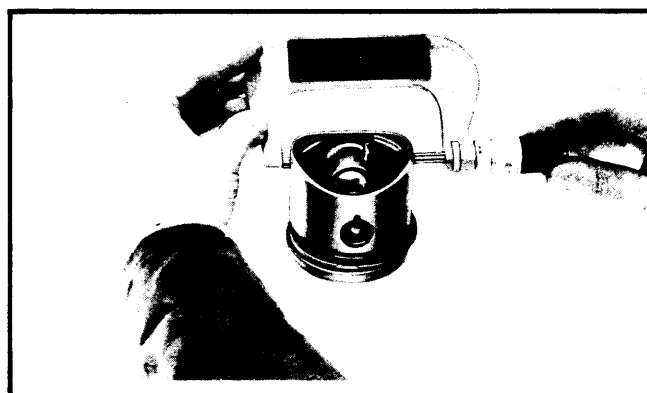

Fig. 6 Measuring Piston Skirt

924 4 CYLINDER (Cont.)

3) Place piston rings squarely in cylinder bore approximately .59" (15 mm) from surface and measure ring gap. If ring side clearance exceeds .039" (1.0 mm), replace rings. Install rings with end gaps offset 120° to each other. Be sure "TOP" mark on ring faces up.

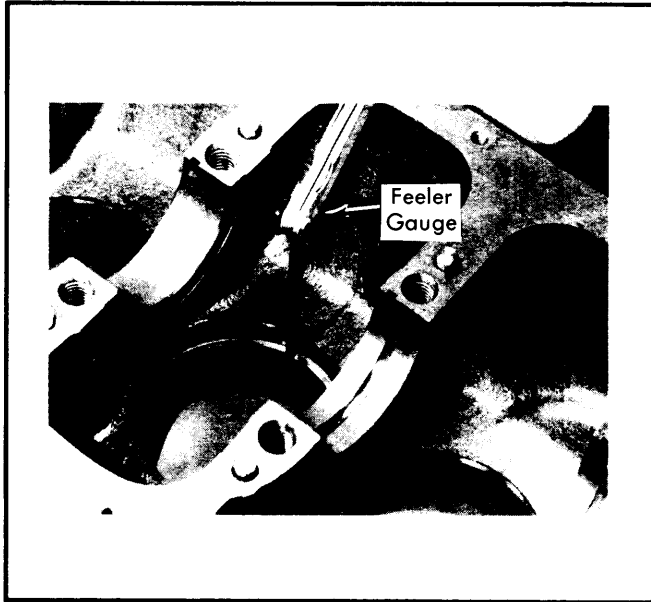

Fig. 7 Measuring Ring Gap

PISTON PINS

Remove circlip and using piston pin remover VW 207c, remove pins. To install, reverse removal procedure.

NOTE — If pin is hard to install, heat piston to about 65°F (60°C).

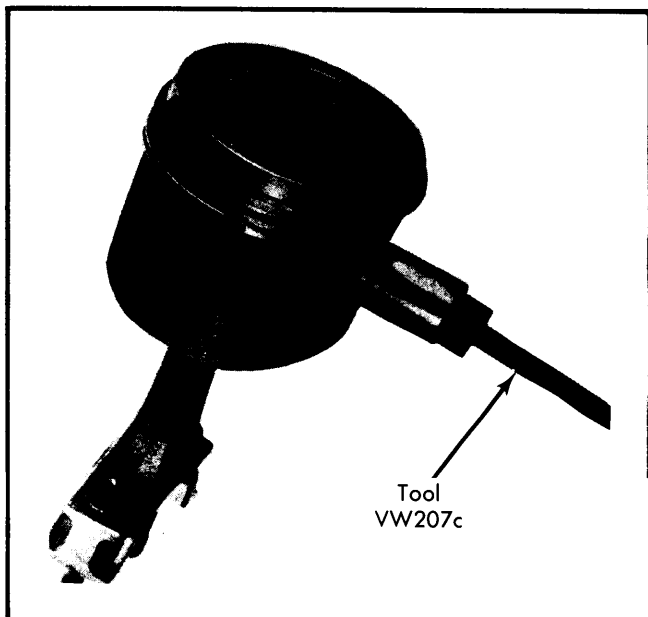

Fig. 8 Piston Pin Removal

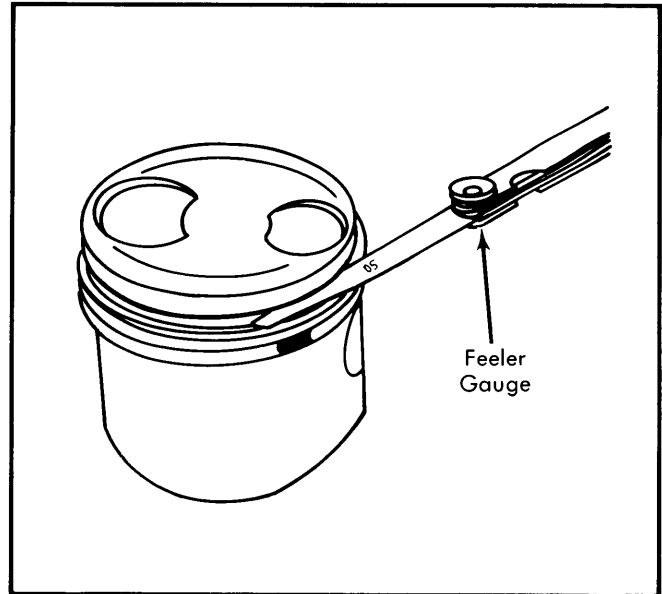

Fig. 9 Piston Ring Side Clearance

CRANKSHAFT MAIN & CONNECTING ROD BEARINGS

MAIN & CONNECTING ROD BEARINGS

1) Push crankshaft toward one end and measure end play at No. 3 thrust bearing. Be sure main bearing caps are marked for reinstallation. Measure connecting rod side play. Remove rod and main bearing caps and check bearing clearance using Plastigage method.



Fig. 10 Measuring Crankshaft End Play

2) Install plain bearing shell into bearing cap. Place grooved shell in block. Do not mix shells. Lubricate bearings and install caps.

924 4 CYLINDER (Cont.)

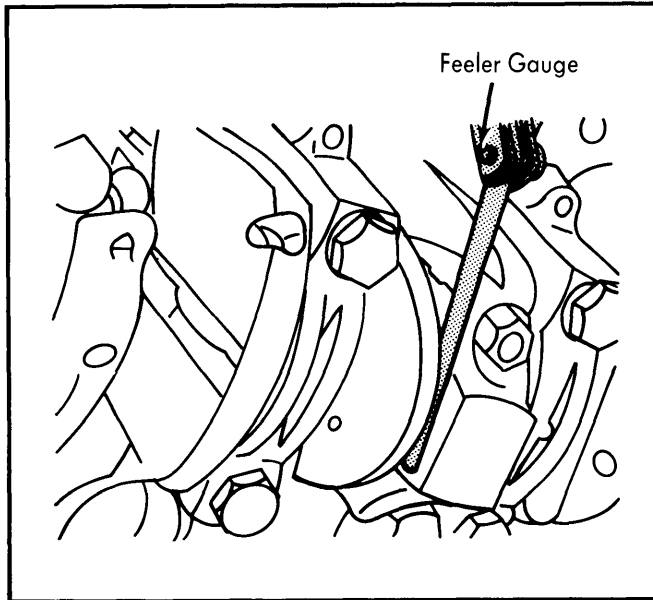

Fig. 11 Measuring Connecting Rod Side Clearance

NOTE — On No. 5. bearing, coat mating surface of bearing with sealing compound.

CAMSHAFT

FRONT MAIN BEARING OIL SEAL

Remove pulley bolt and using oil seal removing tool 10-221 (or equivalent), pry oil seal out of oil pump. Use installing tool 2033 to install new seal.

TIMING BELT

Remove belt cover and loosen drive belt tensioner. Remove crankshaft pulley and drive belt pulley. Remove drive belt. To install, reverse removal procedure.

NOTE — Belt must be tightened until belt can be turned 90° with thumb and index finger at a point midway between crankshaft and camshaft.

1) Remove "V" belt and toothed belt from engine. Remove cylinder head cover and camshaft lubrication tube. Remove distributor and distributor drive.

NOTE — Reinstall nuts handtight after tube has been removed.

2) Remove bearing caps 1, 3 and 5 then carefully, in a crosswise pattern, release bearing caps on 2 and 4.

3) To install camshaft, reverse removal procedure and note the following; Place camshaft into position and install caps 2 and 4 again using a crosswise pattern. Install caps 1, 3 and 5 and tighten all nuts to specifications. Loosen nuts 2 and 4 to install lubrication tube.

NOTE — Make sure that bore is not off center when installing caps. Position caps to check correct position.

VALVE TIMING

1) Set dot on camshaft sprocket in line with pointer on cylinder head cover. Notch on crankshaft pulley must be in line with adjusting lug on oil pump housing.

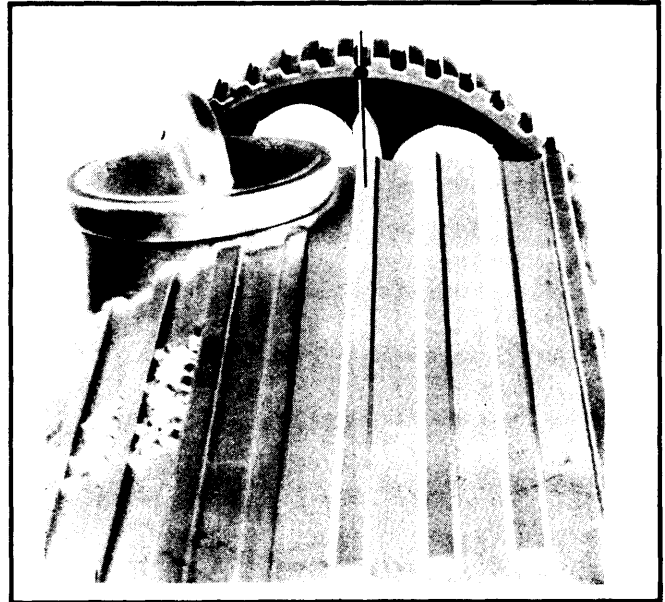

Fig. 12 Camshaft Sprocket Alignment

NOTE — It is also possible to work with TDC mark on flywheel.

2) Adjust valves as previously outlined. Use timing light to check ignition and valve timing.

ENGINE OILING

Crankcase Capacity — 4.7 qts. Add approximately 1 pt. with filter.

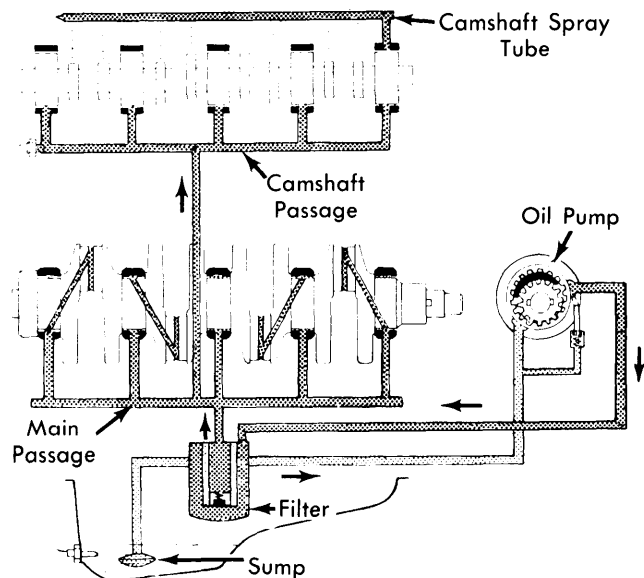

Fig. 13 Engine Oiling System

Porsche Engines

924 4 CYLINDER (Cont.)

Oil Filter — Spin-on type. Change at first oil change and every other one thereafter.

Oil Pressure — 73-101@5000 RPM.

ENGINE OILING SYSTEM

The engine oiling system is full pressure with rotary (sickle) type pump. Oil is picked up by pump through strainer and suction tube. Oil passes through pump and pressure control valve to oil filter and main oil channels. It is then distributed to main bearings, connecting rods and crankshaft. Camshaft lubrication is provided by spray tube at No. 1 cam bearing. Oil pressure switch is located at end of camshaft lubrication passage. A temperature sensor is located in oil pan.

OIL PUMP

Oil pump is sickle type gear driven directly by crankshaft.

ENGINE COOLING

Cooling System Capacity — 7.4 qts.

Thermostat — Opens at approximately 180°F.

Radiator Cap — 12.8-16.4 psi.

Cooling Fan — Comes on at 198°F, goes off at 189°F.

ENGINE SPECIFICATIONS

GENERAL SPECIFICATIONS										
Year	Displ.		Carburetor	HP at RPM	Torque (Ft. Lbs. at RPM)	Compr. Ratio	Bore		Stroke	
	cu. ins.	cc					in.	mm	in.	mm
1977	121	1984	Fuel Inj.	95@5500	109@3000	8.0-1	3.41	86.5	3.32	84.4
1977½	121	1984	Fuel Inj.	110@5750	111@3500	8.5-1	3.41	86.5	3.32	84.4

VALVES							
Engine & Valve	Head Diam. In. (mm)	Face Angle	Seat Angle	Seat Width In. (mm)	Stem Diameter In. (mm)	Stem Clearance In. (mm)	Valve Lift In. (mm)
All Int.	⊙1.496 (38)	45°	45°	.087-.118 (2.2-3.0)	.3532 (8.97)	.0157 (0.4)
Exh.	1.299 (33)	45°	45°	.087-.118 (2.2-3.0)	.3524 (8.95)	.020 (0.5)

⊙ — 1977½ Head Diameter 1.575" (40 mm).

PISTONS, PINS, RINGS						
Engine	PISTONS		PINS		RINGS	
	Clearance In. (mm)	Piston Fit In. (mm)	Rod Fit In. (mm)	Rings	End Gap In. (mm)	Side Clearance In. (mm)
1984 cc	.0012 (.03)0004-.0008 (.01-.02)012-.020 (.3-.5)	.0016-.0028 (.04-.07)

CRANKSHAFT MAIN & CONNECTING ROD BEARINGS							
Engine	MAIN BEARINGS				CONNECTING ROD BEARINGS		
	Journal Diam. In. (mm)	Clearance In. (mm)	Thrust Bearing	Crankshaft End Play In. (mm)	Journal Diam. In. (mm)	Clearance In. (mm)	Side Play In. (mm)
1984 cc	2.518-2.519 (63.95-63.97)	.0008-.0031 (.02-.08)	3	.0020-.0012 (.05-.08)	1.888-1.889 (47.95-47.97)	.0008-.003 (.02-.07)	.004-.007 (.1-.19)

Porsche Engines

924 4 CYLINDER (Cont.) ENGINE SPECIFICATIONS (Cont.)

CAMSHAFT			
Engine	Journal Diam. In. (mm)	Clearance In. (mm)	Lobe Lift In. (mm)
1984 cc	1.0236-1.0245 (26.00-26.02)	.002-.006 (.06-.061)

VALVE TIMING				
Engine	INTAKE		EXHAUST	
	Open (BTDC)	Close (ALDC)	Open (BLDC)	Close (ATDC)
1984 cc	5°	37°	43°	7°
①	4°	44°	44°	4°

① - 1977½.

TIGHTENING SPECIFICATIONS	
Application	Ft. Lbs. (mkg)
Cylinder Head Bolts	①
Cold	72 (10)
Warm	86 (12)
Main Bearing Caps	58 (8)
No 5 Allen Head Bolt	47 (6.5)
Connecting Rod Nuts	43 (6)
Flywheel	65 (9)
Crankshaft Pulley	180 (25)
Oil Pan Bolts	
(M 6)	6 (.8)
(M 8)	11 (1.5)
Exhaust Manifold	18 (2.5)
Intake Manifold	17 (2.4)
Camshaft Bearing Caps	13-18 (1.8-2.5)

① - Bolts must be retorqued after 1000 miles (1600 Km).
Loosen bolts in sequence about 30° and retorque to 86 ft. lbs. (12 mkg).