

6.9 LITER V8

ENGINE CODING

ENGINE IDENTIFICATION

Engine identification number is located on tag attached to engine crankcase. First six digits of code are used to identify engine.

Application	Chassis Type	Engine Code
6.9 Liter	116.036	100.985

ENGINE & CYLINDER HEAD

ENGINE

NOTE — Engine and transmission must be removed as a unit.

Removal — 1) Remove hood, fan, fan shroud and radiator. Remove air cleaner, battery and battery frame. Remove hydraulic lines from hydropneumatic suspension pump. Discharge air-conditioning system.

2) Drain power steering reservoir and remove hoses. Remove all water, vacuum, oil, fuel and electrical lines leading to engine. Remove throttle control shaft.

3) Remove shield between oil pan and reservoir. Remove oil feed and return lines. Remove exhaust pipes and exhaust heat shield. Loosen locknut on drive shaft. Unbolt drive shaft at transmission and push toward the rear. Loosen all connections on transmission. Remove both engine shock absorbers, at frame crossmember.

4) Attach a engine hoist to lifting eyes on engine. Remove rear engine carrier with engine mount. Remove front engine mount. Remove engine and transmission.

Installation — To install reverse removal procedure.

CYLINDER HEAD

NOTE — Cylinder head can only be removed when engine is cold.

Removal — 1) Drain cooling system and crankcase. Remove battery, fan and fan shroud. Disconnect hydraulic oil pump lines. Remove alternator and bracket. Remove windshield washer reservoir and bracket. Disconnect injection lines at injector nozzles, and warm-up compensator.

2) Disconnect fuel supply and return from fuel distributor. Disconnect control linkage, remove mixture regulator assembly with lower housing. Remove throttle control shaft. Remove injection nozzles. Remove bracket for oil lines. Disconnect all electrical lines and vacuum lines. Remove intake manifold.

3) Unbolt exhaust pipe at manifold. Remove timing chain tensioner. Remove timing chain guide rails. Mark camshaft sprocket and timing chain. Carefully remove camshaft sprocket, letting timing chain fall down. Remove cylinder head bolts in reverse of tightening sequence. (Fig. 1).

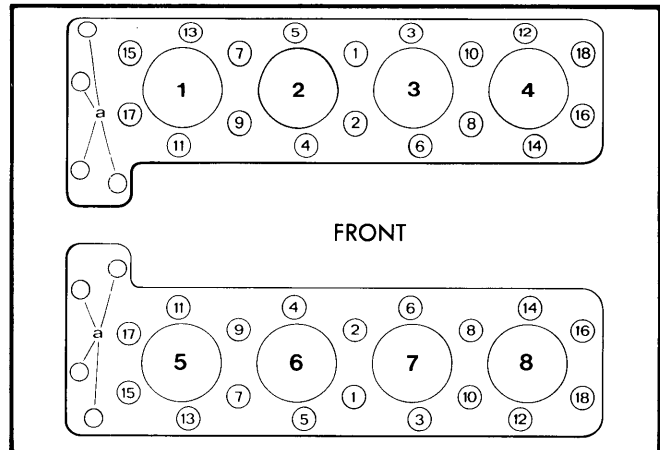

Fig. 1 Cylinder Head Tightening Sequence

NOTE — To remove cylinder head bolts at rear of left cylinder bank, raise engine at transmission mount. Level adjusting switch must be pulled out to first notch.

Installation — To install, reverse removal procedure.

NOTE — Place cylinder head on crankcase and lift, insert new cylinder head gasket.

VALVES

VALVE GUIDE SERVICING

1) Clean valve guide and remove all hard carbon. Using suitable go no-go plug gauges, check valve guide clearance. Drift out old guide using a suitable drift. Check bore in cylinder head and ream to oversize if necessary.

2) Heat cylinder head to 176-194°F (80-90°C) and chill valve guide. Drive valve guide in until lock ring is seated against cylinder head. Allow cylinder head to cool and check guide fit in head.

VALVE STEM OIL SEALS

Removal — 1) Remove camshaft cover. Remove rocker arm. Rotate engine until both valves are closed and supply compressed air to spark plug hole to hold valves closed.

2) Compress valve springs, using suitable valve spring compressor. Remove valve keepers, collar, springs and valve stem oil seal.

Installation — 1) Install valve stem oil seal. On intake guide, position coil spring at top and clamping strap at bottom. On exhaust, place installation bead on bottom next to valve guide.

2) Install springs, collars and keepers, using a suitable valve spring compressor. Install rocker arm and check tappet clearance. Replace camshaft cover and tighten nuts.

VALVE SPRING

With cylinder head and rocker arms removed, compress valve springs with a suitable valve spring compressor. Remove valve keepers, collar and springs.

6.9 LITER V8 (Cont.)

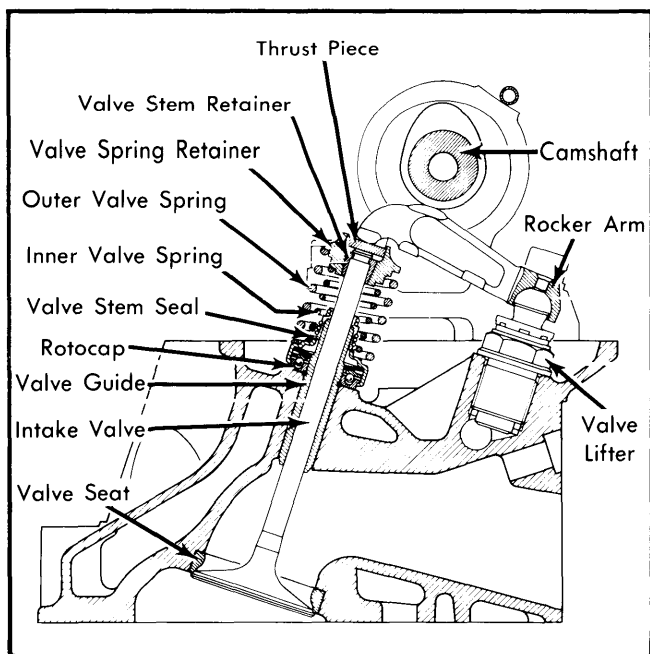

Fig. 2 Valve Assembly

HYDRAULIC VALVE LIFTERS

Removal — Remove camshaft cover and rocker arms. Unscrew hydraulic valve lifters.

Installation — Moisten threads of valve lifter with engine oil and screw into cylinder head. Install rocker arms and camshaft cover. When installing new valve lifters the base setting must be adjusted.

BASE SETTING ADJUSTMENT

NOTE — With new hydraulic valve lifters installed; crank engine for 30 seconds with remote starter switch, before making adjustment.

1) Remove load from valve lifter to be checked, by cranking engine until cam lobe points up. Screw in adapter bushing (700 589 05 21) to dial indicator holder. Screw dial indicator holder to one of the studs in the cylinder head.

2) Insert dial indicator extension through bore in rocker arm, making contact with top of valve lifter. Tighten dial indicator to .16" (4mm) preload. Set dial indicator to zero. Push valve spring down with valve spring compressor, to remove load from valve lifter. Check reading on dial indicator, if reading is between .028-.075" (.7-1.9mm) the base setting is correct. If reading is beyond limit, base setting must be corrected.

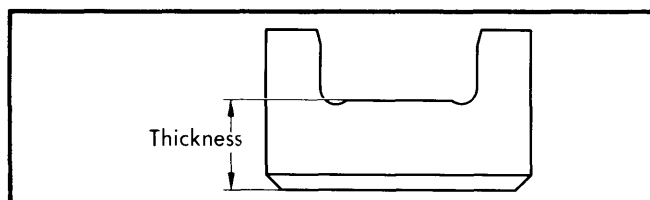

Fig. 3 Thrust Piece

3) To correct base setting, remove rocker arm. Remove thrust piece and insert measuring thrust piece. (Fig. 3) Reinstall rocker arm. Repeat measuring procedure outlined in step 2. Use thrust piece according to measured value in table.

Measured Value In. (mm)	Thrust Piece Thickness In. (mm)
0-.002 (0-.05)	.2146/.2283 (5.45/5.8)
.002-.037 (.06-.087)	.2008 (5.1)
.035-.066 (.88-1.69)	.1870 (4.75)
.067-.099 (1.70-2.51)	.1732 (4.4)
.099-.131 (2.52-3.33)	.1594 (4.05)
.131 (above 3.33)	.1457 (3.7)

4) Reinstall remaining components in reverse of removal procedure. Start engine and listen for valve train noises.



Fig. 4 Dial Indicator Installed

ROCKER ARM ASSEMBLY

Removal — Remove battery and camshaft cover. Rotate camshaft (by remote starter switch) until camshaft lobe is pointed up. Using a suitable valve spring compressor (100 589 06 61 00), position compressor between camshaft and valve spring collar, lever valve downward until rocker arm can be removed.

Installation — Reverse removal procedure.

NOTE — When installing new rocker arms, replace camshaft and check base setting of hydraulic valve lifters.

PISTONS, PINS & RINGS

OIL PAN

Removal — 1) Remove hood, drain cooling system. Remove upper radiator hose. Drain engine oil. Remove throttle control shaft.

2) Remove transmission oil cooler lines. Remove shield between oil pan and oil reservoir, remove oil lines from oil pan. Remove two connecting flanges on oil pan and pull them out. Remove oil pan attaching bolts.

6.9 LITER V8 (Cont.)

3) Remove front engine carriers. Remove engine shock absorbers. Raise engine at front lifting eye, until oil pan can be pulled out, in a forward direction.

Installation — To install, reverse removal procedure.

NOTE — Replace O-ring and rubber seal of connecting flanges. Coat parting surface of oil pan with a sealing compound.

FITTING PISTONS

Measure pistons and cylinder diameters to determine if pistons or cylinders are worn. Oversize pistons are available.

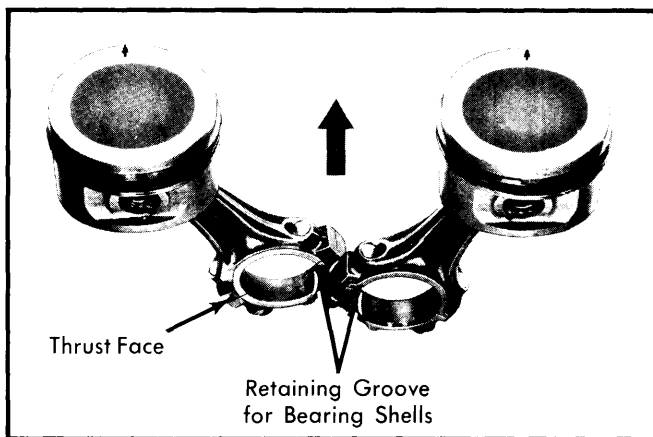

Fig. 5 Piston & Connecting Rod Alignment

PISTON PINS

Piston pin bore is offset from center in the direction of the thrust face side.

CRANKSHAFT MAIN & CONNECTING ROD BEARINGS

MAIN & CONNECTING ROD BEARINGS

Inspect main and connecting rod journals for wear or damage. Maximum wear limit is .02" (.5mm). Regrind crankshaft and install new undersize bearings, if necessary.

REAR MAIN BEARING OIL SEAL

Remove — 1) Remove engine and transmission (See Engine Removal). Drain oil, separate transmission from engine. Remove camshaft covers, and camshaft sprocket (See Camshaft). Remove oil pan (See Oil Pan Removal).

2) Remove front crankcase seal holder. Remove main and connecting rod bearing caps. Mark caps for reassembly. Remove rear bearing seal holder with a suitable tool. Pull double roller chain upward and lift crankshaft. Remove old sealing ring and clean all parts.

Installation — Rubber sealing strip must be installed before fiber seal. Install in reverse of removal procedure.

FRONT MAIN BEARING OIL SEAL

Removal — 1) Remove crankshaft pulley and vibration damper. Remove bolts from seal holder and withdraw seal holder.

2) Remove lock washers on both threaded studs and remove side rail from studs. Support seal holder and drive out seal with suitable tool.

Installation — 1) Heat seal holder and place on suitable support. Press seal in cover. Install side rail over threaded bolts and install lock washers.

2) Coat edges of front cover with sealing compound. Using a wire hook, pull rail outward from seal. Place cover in position on crankcase and remove hook. Install bolts and tighten to specification.

CAMSHAFT

NOTE — If camshaft is replaced, install new rocker arms. Camshaft code is located at rear of shaft.

CAMSHAFT

Removal — 1) Place No. 1 piston at TDC of compression stroke. Remove rocker arms. Remove compression spring of the timing chain tensioner by unscrewing plug (See Fig. 6).



Fig. 6 Timing Chain Tensioner Spring Plug

2) Mark both camshaft sprockets and timing chain. Remove camshaft sprockets and mounting bolts for camshaft bearings. Remove camshafts.

NOTE — The mounting bolt at the rear of the engine can only be removed by raising left side of the engine.

Installation — 1) Oil camshaft bearings, mount bearings with camshaft. Tighten mounting bolts (in steps) from the inside to the outside. Camshaft should turn freely.

2) Install compensating washer (V-notch in washer on top of woodruff key). Install camshaft sprockets and timing chain checking alignment of marks. Turn crankshaft one full revolution and place the piston of No. 1 cylinder at TDC of compression stroke.

6.9 LITER V8 (Cont.)

3) With No. 1 piston at TDC the marks on both camshafts must be in alignment (See Fig. 7). Install oil pipe. Reverse removal procedure to install remaining components.

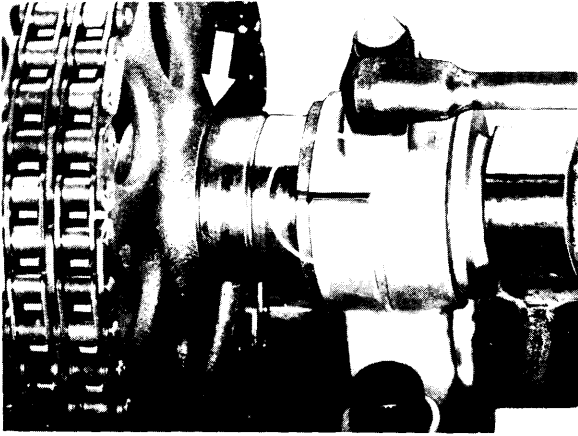

Fig. 7 Camshaft Aligning Marks

2) Brake endless chain and attach new chain with a master link, spring lock facing direction of rotation. Use care not to drop chain down into engine.

Installation – 1) Slowly turn engine in direction of rotation, drawing new chain over sprockets, and pulling old chain from engine. Connect ends of new chain with master link, facing inwards toward camshaft and spring lock facing in direction of rotation.

2) Insert timing chain compression spring and hold in place, put new gasket on plug and screw in place. Check crankshaft in relation to camshaft, to find out if valve timing is correct. Install camshaft covers and spark plugs.

VALVE TIMING

Rotate crankshaft until No. 1 piston is at TDC. Both right and left camshafts timing marks must align with marks on front bearing support (See Fig. 7).

NOTE – Rotate engine by crankshaft, never use camshaft sprocket nuts.

TIMING CHAIN

Removal – 1) Remove camshaft covers and spark plugs. Partially drain cooling system and remove thermostat housing. Remove regulating shaft, between venturi control unit and injection pump. Remove timing chain tensioner.

ENGINE OILING

Crankcase Capacity – 11 qts. with filter

Oil Filter – Full-flow with paper cartridge

Pressure Regulator Valve – Non-adjustable

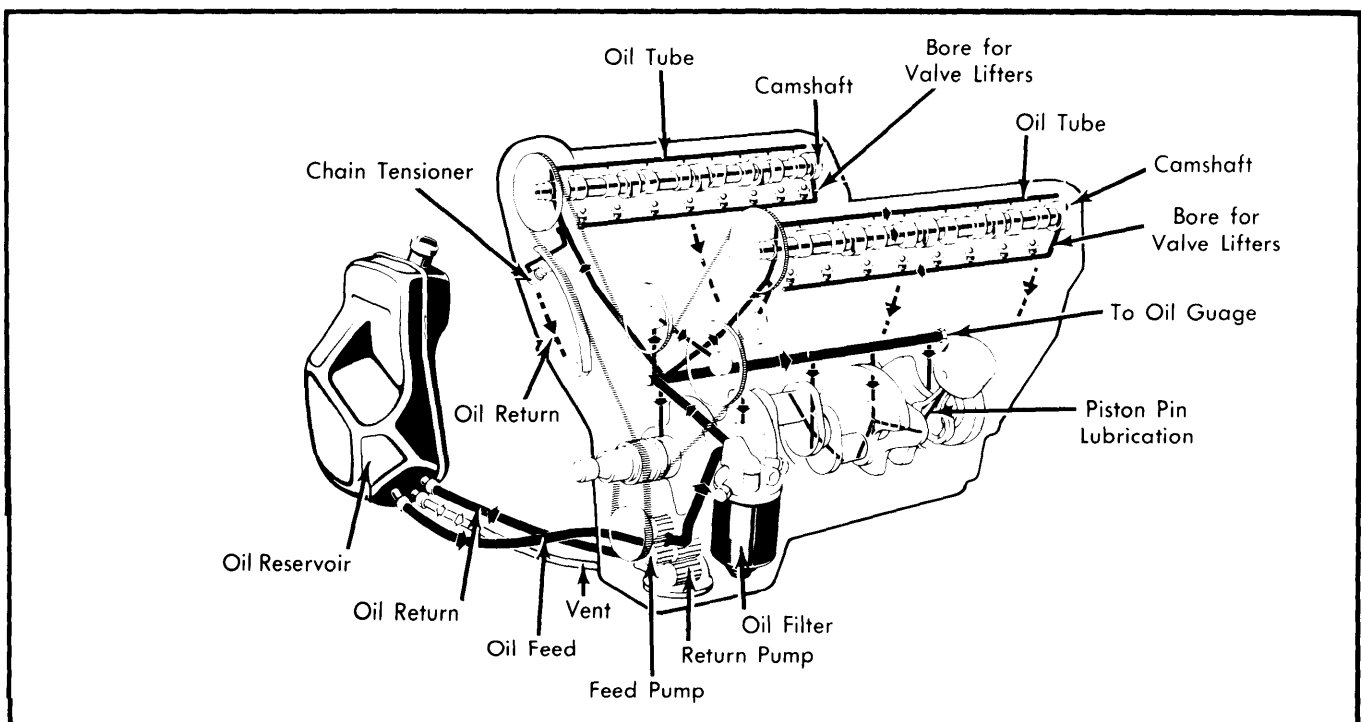

Fig. 8 Engine Oiling System

6.9 LITER V8 (Cont.)

OIL PUMP

A gear type oil pump consisting of a oil feed and oil return pump. The pump is attached to the crankcase and is driven by a duplex roller chain. The oil return pump is larger than the oil feed pump, to limit oil foaming.

ENGINE COOLING SYSTEM

Thermostat – Opens at 189°F (87°C)

Cooling System Capacity – 17 qts.

Radiator Cap – 14 psi

WATER PUMP

Remove bolts and screws attaching bearing housing and water pump housing. With a suitable puller, pull impeller off of pump shaft. Unscrew bolts from cover. Use a long punch inserted in water exhaust bore to release cover (tap lightly with a hammer). Using circlip pliers, take off cover. To reassemble reverse disassembly procedure.

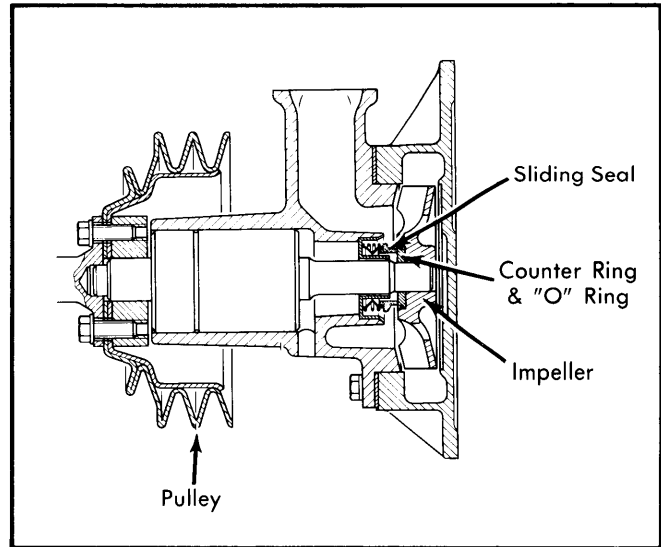

Fig. 9 Water Pump Assembly

ENGINE SPECIFICATION

GENERAL SPECIFICATIONS										
Year	Displ.		Carburetor	HP at RPM	Torque (Ft. Lbs. at RPM)	Compr. Ratio	Bore		Stroke	
	cu. ins.	cc					in.	mm	in.	mm
1977	417.1	6834	Fuel Inj.	250@4000	360@2500	8.0:1	4.21	107	3.74	95

VALVES							
Engine & Valve	Head Diam. In. (mm)	Face Angle	Seat Angle	Seat Width In. (mm)	Stem Diameter In. (mm)	Stem Clearance In. (mm)	Valve Lift In. (mm)
6834 Intake	1.736-1.744 (44.10-44.30)	45°05-.08 (1.3-2.0)	.3525-.3531 (8.955-8.970)
6834 Exhaust	1.455-1.466 (36.95-37.25)	45°06-.08 (1.5-2.0)	.4303-.4311 (10.93-10.95)

VALVE TIMING				
Engine	INTAKE		EXHAUST	
	Open (BTDC)	Close (ALDC)	Open (BLDC)	Close (ATDC)
6834 cc Left	4°	14°	26.5°	11.5°
6834 cc Right	2°	12°	28.5°	13.5°

CAMSHAFT			
Engine	Journal Diam. In. (mm)	Clearance In. (mm)	Lobe Lift In. (mm)
6834 cc0010-.0022 (.025-.057)

Mercedes-Benz Engines

6.9 LITER V8 (Cont.) ENGINE SPECIFICATION (Cont.)

PISTONS, PINS, RINGS						
Engine	PISTONS	PINS		RINGS		
	Clearance In. (mm)	Piston Fit In. (mm)	Rod Fit In. (mm)	Rings	End Gap In. (mm)	Side Clearance In. (mm)
6834 cc	.0005-.0015 (.012-.037)	No. 1	.014-.022 (.35-.55)	.002-.0036 (.050-.092)
				No. 2	.014-.022 (.35-.55)	.0016-.0032 (.040-.082)
				No. 3	.010-.016 (.25-.40)	.0012-.0028 (.030-.072)

CRANKSHAFT MAIN & CONNECTING ROD BEARINGS							
Engine	MAIN BEARINGS				CONNECTING ROD BEARINGS		
	Journal Diam. In. (mm)	Clearance In. (mm)	Thrust Bearing	Crankshaft End Play In. (mm)	Journal Diam. In. (mm)	Clearance In. (mm)	Side Play In. (mm)
6834 cc0016-.0035 (.041-.088)004-.009 (.10-.24)001-.003 (.030-.068)	.009-.015 (.22-.39)

TIGHTENING SPECIFICATIONS

Application	Ft.Lbs (mkg)
Cylinder Head Bolts	
Stage 1	29 (4.0)
Stage 2	①65 (9.0)
Main Bearing Caps	58 (8.0)
Connecting Rod Caps	36 (5.0)
Flywheel	36 (5.0)
Crankshaft Pulley	290 (30)
Camshaft Bearing	36 (5.0)
Camshaft Sprocket	72 (10)
Chain Tensioner Plug	36 (5.0)
Hydraulic Valve Lifters	36 (5.0)

① — Retorque with warm engine to 65 ft. lbs. (9mkg)