

530i & 630CSi 6 CYL. ENGINES

ENGINE CODING

ENGINE IDENTIFICATION

Engine serial number is same as chassis serial number. Engine serial number is stamped in crankcase above starter.

ENGINE, CYLINDER HEAD & MANIFOLDS

ENGINE

1) Remove hood and disconnect battery ground cable. Remove radiator and air cleaner with fuel injection air volume control unit. Disconnect distributor vacuum line and wires from ignition coil. Disconnect fuel feed hose at fuel filter, hose at charcoal filter and vacuum hoses from brake booster. Disconnect all remaining fuel and coolant hoses.

2) Remove engine ground cable. Remove distributor cap and secondary wiring. Disconnect plug from fuel injection control unit and pull harness into engine compartment. Remove all remaining electrical connections.

3) Disconnect wires from starter and alternator. Disconnect accelerator linkage. Remove nuts from engine mounts. Remove protective cover from under engine. Remove power steering pump (if equipped). Attach a hoist to lifting holes at front and rear of engine.

4) Remove transmission. See *Manual Transmission Removal and Automatic Transmission Removal*. On Manual Transmission models, push back rubber boot on slave cylinder, remove circlip and pull slave cylinder out toward front. Disconnect exhaust pipes at front and rear manifolds.

5) Remove throw-out bearing lever and bearing from clutch housing. Raise engine and swing out to right to remove. To install, reverse removal procedure. Install drive pulley in correct position and lubricate contact surfaces of throw-out bearing lever with Molykote Longterm 2 paste.

MANUAL TRANSMISSION

1) Pull up boot from shift lever, remove circlip and pull shift lever up and out. Remove exhaust pipe support bracket. Disconnect drive shaft at transmission, loosen threaded coupling of drive shaft at rear of center support bearing.

2) Remove center support bearing and pull drive shaft from transmission. Remove speedometer cable and disconnect back-up light switch connection. Disconnect transmission from clutch housing. Support front of engine, remove transmission crossmember and transmission.

3) To install, reverse removal procedure. When installing drive shaft, push center support bearing rearward .08" (2 mm) and tighten nuts.

AUTOMATIC TRANSMISSION

1) Disconnect accelerator cable from reverse lever and drain transmission. Remove oil filler tube and plug opening. Remove exhaust system and disconnect lines to transmission. Disconnect wire harness to transmission.

2) Rotate torque converter and remove four bolts securing converter to drive plate. Disconnect shift rod from lever. Disconnect drive shaft coupling at rear of transmission and loosen threaded coupling at rear of center support bearing.

3) Remove center support bearing and pull drive shaft down and out to remove. Disconnect speedometer cable and back-up light connection. Remove transmission crossmember, allowing engine oil pan to rest on front axle crossmember.

4) Place a jack under transmission and remove ground strap. Separate transmission from engine, making sure torque converter stays in housing in transmission. Remove transmission.

5) To install, reverse removal procedure. When installing, make sure center support of torque converter is below edge of transmission. Push center support bearing rearward .08" (2 mm) and tighten nuts. Adjust accelerator cable lever.

INTAKE MANIFOLD

Remove all hoses and lines from manifold. Remove EGR valve and bellows to air volume meter. Remove electrical connector from throttle switch. Detach manifold from supports and bend back supports slightly. Remove intake manifold. To install, reverse removal procedure and replace all gaskets.

CYLINDER HEAD

1) Remove air cleaner, spark plug wire tube and valve cover. Disconnect battery ground cable and drain cooling system. Disconnect fuel line at fuel pump and accelerator linkage.

2) Disconnect all fuel and vacuum lines, along with all wiring from injection system and cylinder head. Disconnect accelerator linkage.

3) Remove upper front cover. See *Engine Front Cover & Oil Seal*. Bend back lock tabs and remove camshaft sprocket bolts and sprocket. Remove timing chain tensioner plug, spring and piston. Disconnect water hoses at base of intake manifolds.

4) Disconnect exhaust pipes. Remove cylinder head bolts and install aligning pins to keep rocker arm shafts from moving. Remove cylinder head.

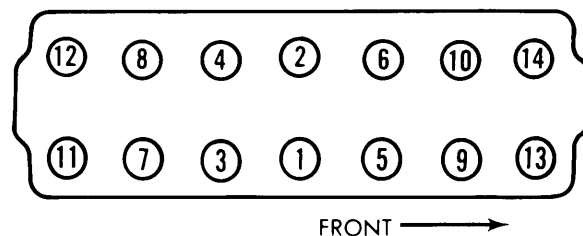

Fig. 1 Cylinder Head Tightening Sequence

5) To install, reverse removal procedure. Thoroughly clean mating surfaces and install a new gasket with sealer. Tighten bolts to specifications in sequence shown in illustration.

530i & 630CSi 6 CYL. ENGINES (Cont.)

6) Install camshaft sprocket and timing chain in correct position. See *Timing Chain Replacement*. Install valve cover and tighten nuts to specification.

7) After installation is complete and engine has run for a short time, shut off and allow to cool to approximately 100°F (38°C). Retighten cylinder head bolts to specification in same sequence.

VALVES

VALVE ARRANGEMENT

Left Side – Intake valves.

Right Side – Exhaust valves.

ROCKER ARM ASSEMBLY

1) Remove camshaft. See *Camshaft Removal*. Push rocker arms and thrust rings against springs and remove circlips from front rocker arm shafts.

2) Remove two countersunk rocker arm shaft locking bolts next to number one bearing bore of camshaft. Install a suitable removing tool (No. 11 3 060) in shaft and pull out of cylinder head. Remove rocker arms, thrust rings, springs and disc.

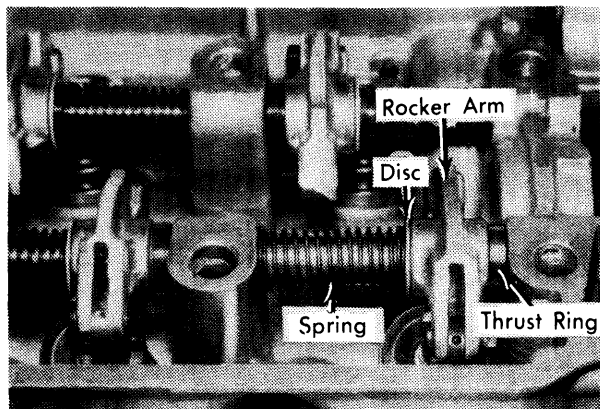

Fig. 2 Installed View of Rocker Arm Assembly

3) Check rocker arm shaft for wear. If diameter is less than .6083" (15.45 mm), replace rocker arm shaft. Check cam follower on rocker arms. If loose, replace rocker arms.

4) Install spring, disc, rocker arm and thrust ring. Install rocker arm shafts and adjust so that recesses in shafts are aligned with cylinder head bolt holes in cylinder head.

5) To disassemble rear rocker arm assemblies, remove rear cover on cylinder head. Use same procedure for rear shafts as used for front. Install self sealing discs on bolts for rear cover plate and use Cabritol sealer on plate gasket.

VALVE GUIDE SERVICING

1) With valve removed, check inside diameter of valve guide. If size exceeds specifications, drive guide out through combustion chamber with a suitable driver (No. 11 1 100).

2) Check size of valve guide bore in cylinder head. If size exceeds .5519" (14.018 mm), an oversize guide must be installed. If guide or bore condition warrant, the following sizes of guides are available for service replacement: .5551" (14.10 mm), .5591" (14.20 mm), and .5630" (14.30 mm).

3) Guides require a .0013-.0027" (.033-.069 mm) press fit in cylinder head, with head heated to 428-482°F (220-250°C). Ream head bores according to guide size being installed.

4) Using suitable driver (No. 11 1 120), drive guide into cylinder head from top until top of guide protrudes .591" (15.0 mm). Ream valve guide until correct clearance with valve is obtained.

VALVE STEM OIL SEALS

A rubber umbrella type oil seal is installed on valve stem before valve spring is installed.

VALVE SPRING

1) With rocker arms and shaft removed, compress valve spring with a suitable valve spring compressor (No. 11 1 600). Remove valve keepers, release spring compressor and remove spring and retainer.

2) Check valve spring free length, and if less than specified, replace spring. Also check spring pressure in a suitable tester. Spring compressed length and pressure should be as indicated in table.

3) Install spring with green or white paint stripe end (tight coil end) against cylinder head. To install, reverse removal procedure.

VALVE CLEARANCE ADJUSTMENT

Remove valve cover and rotate engine until piston of valves being adjusted is at TDC of compression stroke. Loosen nut on rocker arm and rotate adjustment cam until correct clearance is obtained. Check or adjust valve clearance with engine hot. Valve clearance for both intake and exhaust valves is .012-.014" (.30-.35 mm).

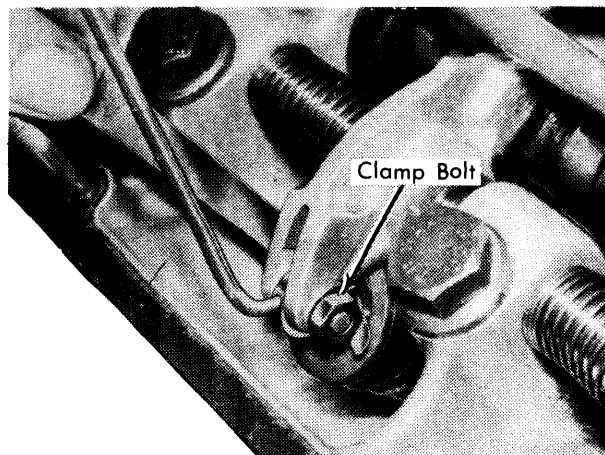

Fig. 3 Procedure to Adjust Valve Tappet Clearance

530i & 630CSi 6 CYL. ENGINES (Cont.)

PISTONS, PINS & RINGS

OIL PAN

- 1) Remove protective cover from under engine, drain oil and remove front suspension stabilizer. Loosen alternator and remove belt.
- 2) Remove power steering pump (if equipped) but do not disconnect hoses. Remove bolt securing power steering pump bracket to side of oil pan.
- 3) Loosen bearing block until oil pan can be removed. Detach support bracket above slave cylinder from crankcase. Rotate crankshaft until No. 6 connecting rod is above oil pan mating surface of crankcase.
- 4) Remove oil pan retaining bolts, lower front of oil pan, turn rear of pan towards support bracket and remove oil pan. To install, reverse removal procedure. Clean mating surfaces and apply Atmosit Sealer to junctions of crankcase and timing cover, and flywheel end cover.

PISTON & ROD ASSEMBLY

- 1) With cylinder head and oil pan removed, remove connecting rod cap. Push piston and rod assembly up and out through top of motor.
- 2) To install, insert bearing halves in rod and rod cap. Position rings so that ring gaps are approximately 180° apart from each other.
- 3) Compress piston rings and install piston in cylinder with arrow toward front of engine. Push piston into cylinder and make sure bearings are properly seated against crankshaft journal.
- 4) Match numbers on rod and rod cap and install on same side. Tighten nuts to specifications.



Fig. 4 View Showing Connecting Rod Cap Installation

PISTON PIN REPLACEMENT

- 1) With piston and rod assembly removed, remove circlips from piston pin hole in piston. Drive out piston pin and separate piston from connecting rod. Thoroughly clean and inspect rod and piston.
- 2) Piston pins are manufactured in two classes. Pin class is designated by color code on pin or a letter stamped in pin. A corresponding letter is stamped in piston. Pin-to-piston clearance is same for each class of pin, but pin-to-rod clearance varies depending on class of pin. See *Specifications*.

Piston Pin Class Designation

Application	Pin Diameter In. (mm)
White or "W".....	.8660-.8661 (21.997-22.000)
Black or "S".....	.8659-.8660 (21.994-21.997)

- 3) Classes of pins and pistons must not be interchanged. If piston or pin is replaced, it must be replaced with one of a corresponding class and weight. Weight classification is designated by a "+" or a "-" stamped in top of piston.
- 4) Check pin-to-piston clearance, if clearance exceeds that specified and pin is not worn, replace piston. Check pin-to-rod clearance, if clearance exceeds that specified, depending on pin class, new bushing must be installed.
- 5) Press out old bushing and install new one with split in bushing rotated 90° from oil hole in connecting rod. Drill through oil hole in connecting rod. Ream bushing to specified clearance with piston pin.
- 6) If connecting rod is replaced, replace with rod which is within 4 grams of rod being replaced. Position piston on connecting rod with arrow on piston facing in same direction as oil hole in connecting rod. Lubricate and install piston pin and circlips.

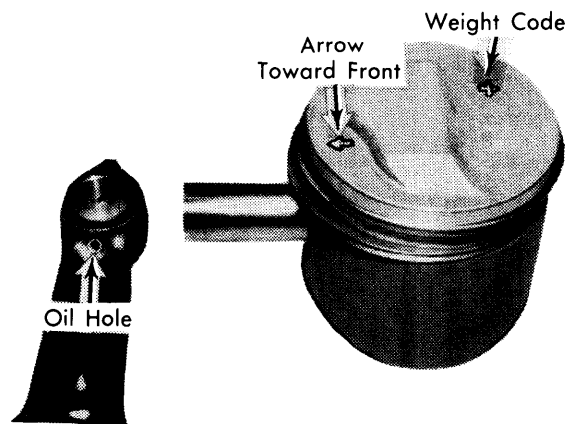

Fig. 5 Piston & Connecting Rod Assembly & Markings

FITTING PISTONS

- 1) With piston removed and disassembled from connecting rod, measure diameter of piston. Measure with micrometer

530i & 630CSi 6 CYL. ENGINES (Cont.)

positioned 90° from pin hole and at a point measured from bottom of piston skirt (Distance "A", see Fig. 7). **NOTE** — Distance "A" depends on piston manufacturer, see table below.

Application	Manufacture	Distance "A"
530i	Mahle	.807" (20.5 mm)
530i	KS	1.033" (26.25 mm)
630i	Mahle	0.630" (16.00 mm)
630i	KS	0.947" (24.05 mm)

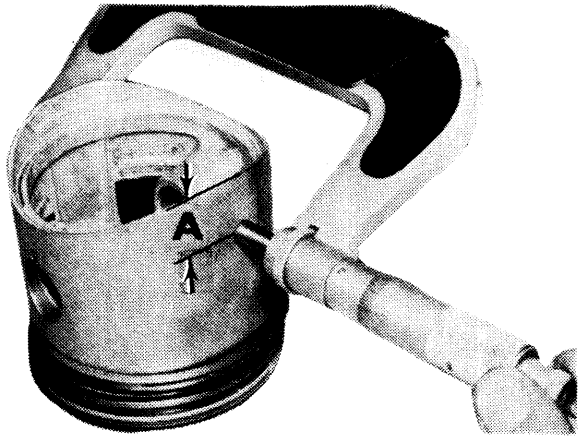

Fig. 6 View Showing Correct Procedure to Measure Piston Diameter

2) Measure inside diameter of bore in crankcase. If clearance exceeds specification, crankcase must be bored for next over-size piston. Pistons are available in .010" (.25 mm) and .020" (.50 mm) oversize.

3) Check piston ring side clearance and end gap. If new rings are installed, install with word "TOP" stamped in ring toward top of piston.

CRANKSHAFT MAIN & CONNECTING ROD BEARINGS

MAIN & CONNECTING ROD BEARING SERVICE

1) With engine removed, remove clutch, flywheel, cylinder head, oil pan and timing chain. See *Timing Chain Replacement*. Remove rear main bearing oil seal mount.

2) Remove pistons and connecting rods. Remove main bearing caps and lift out crankshaft. Thoroughly clean and inspect crankshaft. Blow out oil passages with compressed air.

3) Main bearings journals are manufactured in two standard sizes. Sizes are designated by a colored dot on crankshaft balance weight next to individual journal (see illustration). Color code designation is given in specifications.

4) Check main and connecting rod bearing clearance using the Plastigage method. If bearing clearance is more than specified, crankshaft must be ground to next undersize. Bearings for undersize crankshafts are available in .010" (.25 mm), .020" (.50 mm) and .030" (.75 mm) undersizes.

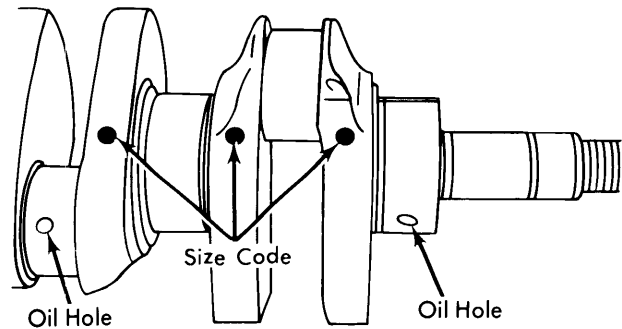

Fig. 7 Crankshaft Color Code Markings

5) Install bearing halves in crankcase and bearing caps. Lubricate crankshaft bearing journals and install crankshaft in crankcase.

6) Install bearing caps with numbers on caps running from one through six in order from front to rear. Install caps with bearing locks on same side as bearing locks in crankcase.

7) Tighten caps to specifications. Check crankshaft endplay. See *Thrust Bearing Alignment*. To install remaining components, reverse removal procedure.

NOTE — Ground crankshafts are marked with painted stripes (See Fig. 8).

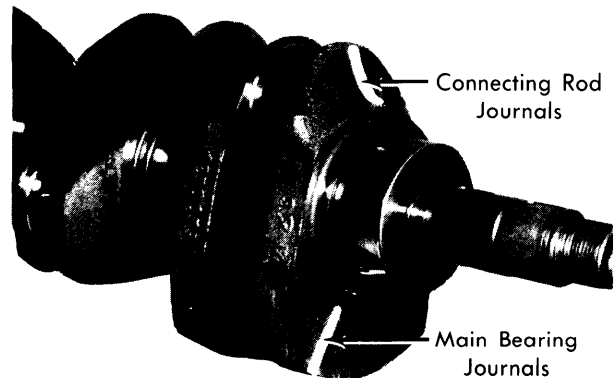

Fig. 8 View Showing Crankshaft Undersize Markings

Crankshaft Journal Sizes

Connecting Rod	In. (mm)
Standard	1.888-1.889 (47.97-47.99)
1 paint stripe	1.852-1.853 (47.72-47.74)
2 paint stripes	1.851-1.852 (47.48-47.49)
3 paint stripes	1.850-1.851 (47.22-47.24)
Main Bearings Red Code	In. (mm)
Standard	2.361-2.362 (59.98-59.99)
1 paint stripe	2.324-2.325 (59.73-59.74)
2 paint stripes	2.323-2.324 (59.48-59.49)
3 paint stripes	2.322-2.323 (59.23-59.24)
Main Bearings Blue Code	In. (mm)
Standard	2.361-2.362 (59.98-59.99)
1 paint stripe	2.324-2.325 (59.72-59.73)
2 paint stripes	2.323-2.324 (59.47-59.48)
3 paint stripes	2.322-2.323 (59.22-59.23)

530i & 630CSi 6 CYL. ENGINES (Cont.)

THRUST BEARING ALIGNMENT

1) With flywheel installed, check crankshaft end play. If end play exceeds .007" (.18 mm), an oversize thrust bearing must be installed.

2) Standard thrust bearing width is 1.1823-1.1835" (30.03-30.06 mm). Oversize bearings are available in widths of 1.1902-1.1913" (30.23-30.26 mm), 1.1980-1.1996" (30.43-30.47 mm) and 1.2059-1.2071" (30.63-30.66 mm).

REAR MAIN BEARING OIL SEAL REPLACEMENT

NOTE – To replace rear main bearing oil seal in vehicle, transmission must be removed.

1) Remove clutch and flywheel and drain engine oil. Remove bolts securing oil pan to rear main bearing oil seal mount.

2) Pry oil pan down at area around seal mount, taking care not to damage gasket. Remove bolts securing seal mount to crankcase and remove mount.

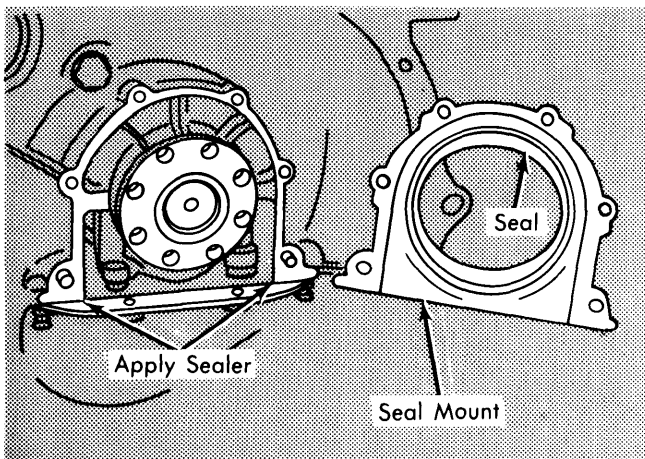

Fig. 9 Installing Rear Main Bearing Oil Seal

3) Pry out old seal and install new one making sure it is fully seated in mount. Apply Atmosit sealer to junction of oil pan and seal mount. To install mount, reverse removal procedure.

ENGINE FRONT COVER AND OIL SEAL

Upper Front Engine Cover – 1) Remove distributor cap and valve cover. Remove thermostat housing and thermostat. Rotate crankshaft until number one cylinder is at TDC of compression stroke. Distributor rotor should point at notch in distributor.

2) Remove timing cover bolts, push rotor in clockwise direction and remove cover with distributor drive. Pull distributor drive out of front cover.

3) To install, thoroughly clean mounting surfaces and use new gasket with sealer. Install distributor drive in camshaft. Rotate rotor counterclockwise approximately 1.38" (35.05 mm) from notch in distributor housing, and install cover.

4) Lightly tighten bolts one and two (see illustration), then tighten remaining bolts to specification in sequence shown in illustration. Tighten bolts one and two to specification. To install remaining components, reverse removal procedure.

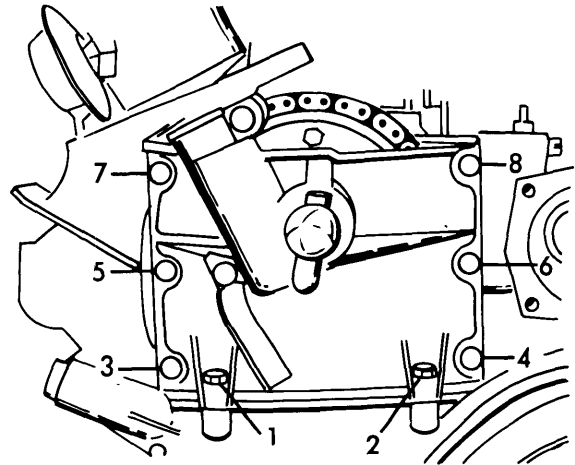

Fig. 10 Upper Front Cover Tightening Sequence

Lower Front Engine Cover – 1) Remove upper front engine cover as previously outlined. Remove timing chain tensioner piston, fan clutch and crankshaft pulley. Remove lower front engine cover.

2) Replace oil seal. To install cover, reverse removal procedure. Thoroughly clean mating surfaces and use new gasket with sealer. Tighten bolts to specification.

NOTE – Oil seal can be replaced without removing lower front engine cover.

3) Remove protective cover from under engine. Remove alternator drive belt. Place a piece of cardboard in front of crankshaft pulley, against radiator.

4) Remove crankshaft pulley nut and remove pulley. Pry out old seal and install new one. If sealing portion of pulley has a groove worn in it, install seal so that sealing edge does not run in groove.

CAMSHAFT

CAMSHAFT

1) Remove cylinder head as previously outlined. Remove fuel pump and fuel pump push rod. Remove oil distribution pipe. With camshaft still positioned at TDC for number one cylinder, open intake valve clearance on No. 2 and No. 4 cylinders.

2) Attach a suitable pressure frame (No.11 1 060) to cylinder head to open all valves. Remove bolts securing camshaft thrust plate to cylinder head and carefully withdraw camshaft.

3) Install camshaft in cylinder head and tighten down thrust plate. Set cylinder six to overlap and release pressure plate. The tapped hole in sprocket flange must align with cast protrusion in cylinder head (see illustration). Check camshaft endplay.

530i & 630CSi 6 CYL. ENGINES (Cont.)

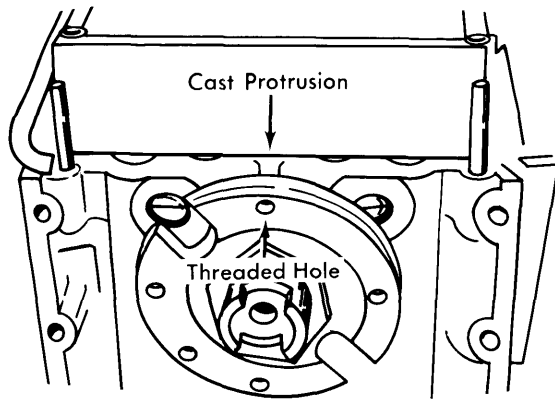

Fig. 11 View Showing Proper Camshaft Alignment

4) Install oil pipe, making sure seals are installed above and below pipe at points where it is bolted to head. Oil pipe must be installed, so oil holes spray between rocker arms and cams of intake and exhaust valves.

5) To install remaining components, reverse removal procedure.

CAMSHAFT ENDPLAY

Check camshaft endplay with a feeler gauge. If endplay exceeds .001-.007" (.03-.18 mm), replace camshaft thrust plate.

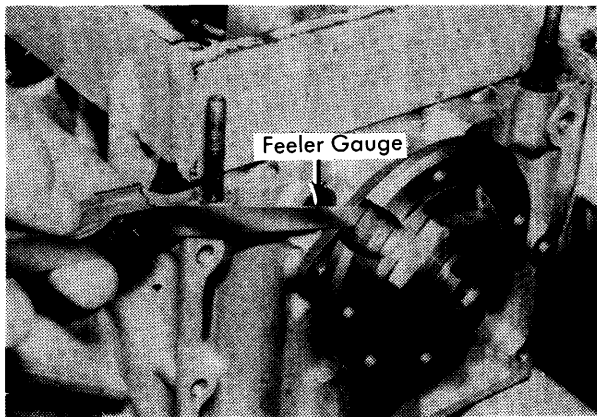

Fig. 12 Using Feeler Gauge to Check Camshaft End Play

TIMING CHAIN REPLACEMENT

1) Rotate crankshaft until number one cylinder is at TDC of compression stroke. Rotor should point to notch in distributor. Remove front engine covers as previously outlined. Mark front side of timing chain for installation.

2) Bend over lock tabs and remove camshaft sprocket with timing chain. If mileage of vehicle exceeds 30,000 miles, replace timing chain. Replace sprockets if worn or damaged.

3) To replace crankshaft sprocket, remove oil pan, oil pump sprocket and chain. Remove Woodruff key and "O" ring and pull off crankshaft sprocket with a suitable puller (No. 11 1 200). To install, reverse removal procedure. Adjust oil pump chain tension.

4) To install timing chain, reverse removal procedure, making sure number one cylinder is at TDC of compression stroke. Line up tapped hole in sprocket hub with cast protrusion in cylinder head and install timing chain and sprocket.

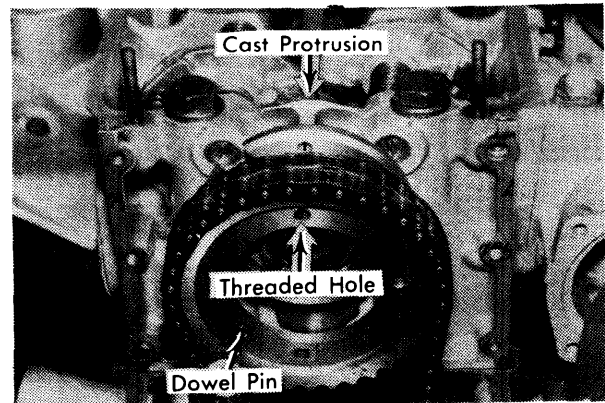

Fig. 13 Correct Alignment for Timing Chain Installation

TIMING CHAIN TENSIONER

1) Remove tensioner plug, spring and piston. Check length of spring and piston assembly. Length of spring should be 6.122" (155.5 mm). Piston assembly length should be 2.441" (62.0 mm).

2) Check piston with compressed air to see if air vent slots (see illustration) are plugged. Clean slots if air does not pass through. When assembling piston, do not block air vents with disc.

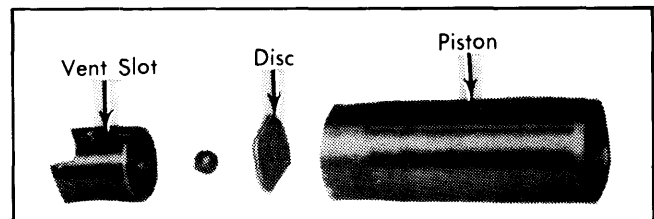

Fig. 14 Exploded View of Timing Chain Tensioner Piston

3) Install piston, spring with conical end toward plug and slightly tighten plug. Fill oil well full of oil and remove valve cover to vent air from piston. Move tensioning rail back and forth until oil comes out at plug. Tighten plug and reverse removal procedure to install remaining components.

ENGINE OILING

ENGINE OILING SYSTEM

Full pressure oil system, utilizing a chain driven Eaton rotor type oil pump, a full flow oil filter and a pressure regulator valve.

Crankcase Capacity — 6 qts.

Oil Filter — Full-flow, paper element type.

Normal Oil Pressure — 26-29 psi (18-20 kg/cm²) at idle and 72.5 psi (51 kg/cm²) at full speed.

Pressure Regulator Valve — Mounted in oil pump. See *Oil Pump Removal*.

530i & 630CSi 6 CYL. ENGINES (Cont.)

OIL PUMP

1) Remove oil pan, front engine covers and timing chain as previously outlined. Remove oil pump drive sprocket and chain. Remove oil pump.

2) Remove pressure regulator plug, spring and piston. Remove pump cover and thoroughly clean and inspect all components. Check clearance between inner and outer rotors. If clearance exceeds maximum specified, replace rotors.

3) Check clearance between outer rotor and pump body and clearance between rotor sealing face and mating surface of pump body and pump cover. If either clearance exceeds maximum specified, replace pump body.

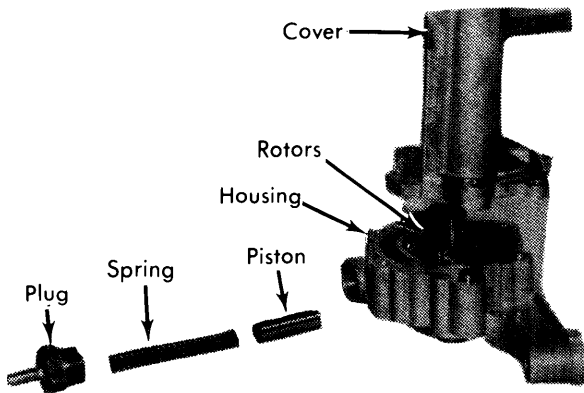

Fig. 15 View of Oil Pump Assembly

4) To remove sprocket flange, pull with suitable tool. Install flange so that distance between sprocket side of flange and sealing side of inner rotor is $1.744 \pm .004$ " ($44.30 \pm .10$ mm).

5) Check free length of regulator spring, if less than specified, replace spring. To assemble pump, reverse removal procedure. Attach oil pump to crankcase and install sprocket and chain. Chain should slightly depress when pushed in with thumb.

6) If chain depresses more than recommended, remove pump and install shims between pump and crankcase mounting points. Make sure oil holes line up on front shim. Rear shim must be same thickness as front. To install remaining components, reverse removal procedure.

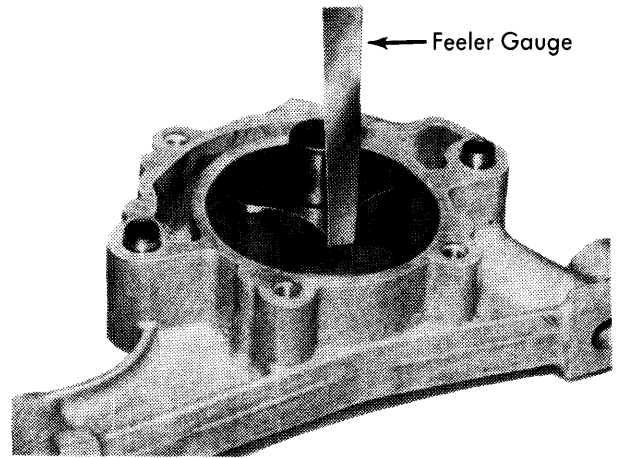

Fig. 16 Using Feeler Gauge to Check Rotor Clearance

Oil Pump Specifications	
Application	Measurement In. (mm)
Rotor-to-Rotor Clearance	.0047-.0118 (.12-.30)
Rotor-to-Housing Clearance	.0029-.0049 (.07-.13)
Sealing Face-to-Housing Clearance	.002-.0036" (.05-.09)
Regulator Spring Free Length	2.677 (67.99)

ENGINE COOLING

WATER PUMP

Remove clutch fan, pulley, side bar and connecting hose. Remove water pump. To install, reverse removal procedure. Use new gaskets and sealer.

Thermostat — Opens at 183°F (84°C) on man. trans. models or at 176°F (80°C) on auto. trans. models.

Cooling System Capacity — 12.7 qts.

ENGINE SPECIFICATIONS

GENERAL SPECIFICATIONS										
Year	Displ.		Carburetor	HP at RPM	Torque (Ft. Lbs. at RPM)	Compr. Ratio	Bore		Stroke	
	cu. ins.	cc					in.	mm	in.	mm
1977	182	2985	Fuel Inj.	175@5500	188@4500	8.1:1	3.504	89	3.150	80

530i & 630CSi 6 CYL. ENGINES (Cont.)

ENGINE SPECIFICATIONS (Cont.)

VALVES							
Engine & Valve	Head Diam. In. (mm)	Face Angle	Seat Angle	Seat Width In. (mm)	Stem Diameter In. (mm)	Stem Clearance In. (mm)	Valve Lift In. (mm)
2985 cc Intake	1.811 (46.0)	45°	46°	.063-.079 (1.6-2.0)	.3135-.3149 (7.963-7.998)	.0010-.0022 (.025-.055)
Exhaust	1.496 (38.0)	45°	46°	.079-.095 (2.0-2.4)	.3128-.3135 (7.945-7.963)	.0016-.0028 (.040-.070)

VALVE SPRINGS			
Engine	Free Length In. (mm)	PRESSURE Lbs. @ In. (kg @ mm)	
		Valve Closed	Valve Open
2985 cc	① 1.712 (43.5)	64±2.6@1.480 (29±1.2@37.6)

① — Some springs are 1.811" (46.0 mm), depending on spring manufacturer.

② — On models with automatic transmission; 154±6 lbs.@1.122" (70±2.8 kg@28.5 mm).

PISTONS, PINS, RINGS						
Engine	PISTONS	PINS		RINGS		
	Clearance In. (mm)	Piston Fit In. (mm)	Rod Fit In. (mm)	Rings	End Gap In. (mm)	Side Clearance In. (mm)
2985 cc	.0016-.0018 (.040-.045)	.0000-.0002 (.001-.005)	① .0002-.0005 (.005-.013) ② .0003-.0006 (.008-.016)	No. 1	.012-.020 (.30-.50)	③ .002-.004 (.06-.09)
				No. 2	.008-.016 (.20-.40)	③ .001-.002 (.03-.06)
				Oil	.010-.016 (.25-.40)	③ .0008-.002 (.02-.05)

① — White color code.

② — Black color code.

③ — Mahle specifications shown; For KS, No. 1 .002-.004" (.06-.09 mm), No. 2 .002-.003" (.04-.07 mm), Oil .001-.002 (.03-.06 mm). For Alkan, No. 1 .003-.004" (.07-.10 mm), No. 2 .001-.002" (.03-.06 mm), Oil .001-.002" (.03-.06 mm).

CRANKSHAFT MAIN & CONNECTING ROD BEARINGS							
Engine	MAIN BEARINGS				CONNECTING ROD BEARINGS		
	Journal Diam. In. (mm)	Clearance In. (mm)	Thrust Bearing	Crankshaft End Play In. (mm)	Journal Diam. In. (mm)	Clearance In. (mm)	Side Play In. (mm)
2985 cc Red Code	2.3614-2.3618 (59.98-59.99)	.0012-.0028 (.030-.070)	No. 4	.0033-.0069 (.085-.174)	1.8888-1.8894 (47.975-47.991)	.0009-.0027 (.023-.069)
Blue Code	2.3610-2.3614 (59.97-59.98)	.0012-.0027 (.030-.068)					

BMW Engines

530i & 630CSi 6 CYL. ENGINES (Cont.)

ENGINE SPECIFICATIONS (Cont.)

CAMSHAFT			
Engine	Journal Diam. In. (mm)	Clearance In. (mm)	Lobe Lift In. (mm)
2985 cc No. 1	1.3764-1.3770 (34.96-34.98)	.0013-.003 (.034-.075)	.2802 (7.12)
No. 2	1.7304-1.7310 (43.95-43.97)		
No. 3	1.7704-1.7710 (44.97-44.98)		
No. 4	1.8094-1.8100 (45.96-45.97)		

VALVE TIMING				
Engine	INTAKE		EXHAUST	
	Open (BTDC)	Close (ALDC)	Open (BLDC)	Close (ATDC)
2985 cc ^①	14°	54°	54°	14°
2985 cc ^②	26°	66°	66°	26°

① — With .020" (.51 mm) clearance between heel of camshaft and rocker pad.

② — With .015" (.38 mm) clearance between heel of camshaft and rocker pad.

TIGHTENING SPECIFICATIONS

Application	Ft. Lbs. (mkg)
Cylinder Head Bolts ①	
1st Stage	25-32 (3.5-4.4)
2nd Stage	43-47 (6.0-6.5)
3rd Stage	49-52 (6.8-7.2)
Main Bearing Bolts	42-46 (5.8-6.4)
Rod Cap Nuts	38-41 (5.3-5.7)
Camshaft Thrust Plate	101-108 (14.0-15.0)
Upper Front Engine Cover	7-8 (0.9-1.1)
Lower Front Engine Cover	7-8 (0.9-1.1)
Oil Pan Bolts	7-8 (0.9-1.1)
Timing Chain Tensioner Plug	22-29 (3.0-4.0)
Rocker Arm Clamp Bolt	6.5-8.0 (0.8-1.1)
Flywheel Bolts ②	72-84 (10.0-11.6)
Crankshaft Pulley Nut	
Flat Nut	173-188 (24.0-26.0)
Shoulder Nut	318-333 (44.0-46.0)
Regulator Valve Plug (Oil Pump)	18-22 (2.5-3.0)
Camshaft Oil Pipe Hollow Bolt	8-9.5 (1.1-1.3)

① — With engine at normal operating temperature.

② — Coat threads with Loctite.