

320i 4 CYLINDER

ENGINE CODING

ENGINE IDENTIFICATION

Identification number is located on tag attached to engine crankcase. First six digits of code are used to identify engine.

ENGINE & CYLINDER HEAD

ENGINE

NOTE — The "A" behind model number is for automatic transmission models.

Removal — 1) On 320i models, remove all mounting bolts accessible from above. Remove exhaust support and exhaust pipe at manifold. Remove drive shaft at transmission, remove center bearing. Remove drive shaft at center journal. Remove speedometer cable, disconnect back-up light switch.

2) Remove center console from transmission, remove circlip and washer, pull out selector rod. Remove clutch slave cylinder, support transmission with jack or stand. Remove crossmember and remaining transmission mounting bolts. Remove transmission towards rear of vehicle.

3) On 320i A, remove accelerator cable. Remove all mounting bolts accessible from above. Remove oil filler neck and drain oil. Remove exhaust support and exhaust pipe at manifold. Remove speedometer drive cable. Remove drive shaft at transmission, remove center bearing and remove drive shaft at center journal. Remove selector rod at selector lever.

4) Remove drive plate bolts from torque converter. Remove transmission oil cooler lines, support transmission with jack or stand. Remove crossmember at body, remove remaining transmission mounting bolts. Remove transmission and torque converter from vehicle.

5) Remove radiator and cowl, disconnect battery, disconnect wires to injection valves, marking location for reassembly. Remove fuel lines and hoses to pressure converter. Disconnect wires from distributor and central electrical plug, remove harness from holders on wheelhouse.

6) Install engine sling (tool No. 11 0 000). Remove left engine mount, and upper engine damper. Remove right engine mount, remove engine from vehicle.

Installation — Reverse removal procedure, making sure torque converter is positioned correctly before installing.

CYLINDER HEAD

Removal — 1) Pull off breather tube, then pull hose with connector out of tube. Dismantle air cleaner assembly. Disconnect ground lead from battery. Drain cooling system. Loosen clamp screw and pull out choke cable.

2) Remove wires to injection valves (mark for reassembly). Remove pressure converter hoses, water hoses at cylinder head and crankcase hoses at throttle housing and thermo valve (marking for reassembly). Remove upper timing case cover, disconnect plug connectors and ignition coil wires. Remove distributor cap and pull plugs off cold start valve, auxiliary air valve and timing valve. Disconnect oil pressure switch wire.

3) Set piston of No. 1 cylinder at TDC, (rotor points to notch in distributor housing, indicator points to notch in pulley). Remove timing chain tensioner and timing chain sprocket. Remove exhaust pipe at manifold and holder to transmission. Remove cylinder head bolts in reverse sequence of tightening, remove cylinder head.

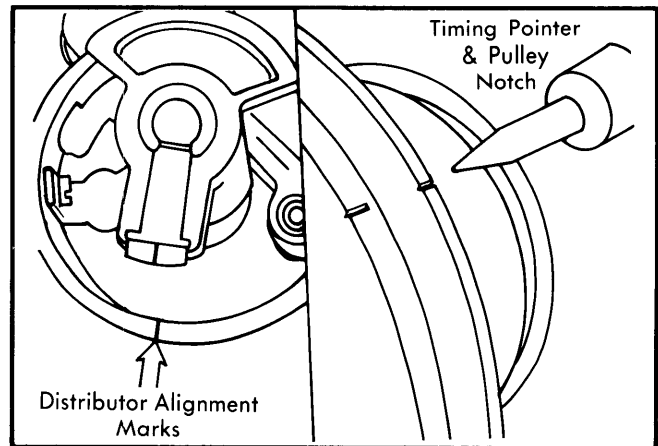

Fig. 1 Correct Procedure to Set No. 1 Piston at TDC

Installation — Ensure installation guides extend .197" (5 mm) beyond cylinder head mounting surface. Also be sure there is no oil in blind holes, or head bolts will not be able to exert required holding force on head. Replace cylinder head and components in reverse of removal procedure, tightening head bolts, in a series of steps, according to sequence illustrated (with engine at normal operating temperature).

NOTE — Retorque cylinder head bolts after 600 miles (1000 km).

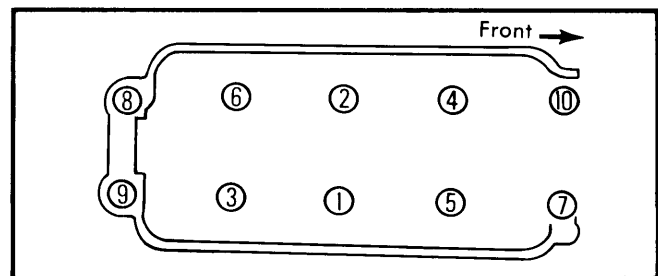

Fig. 2 Cylinder Head Tightening Sequence

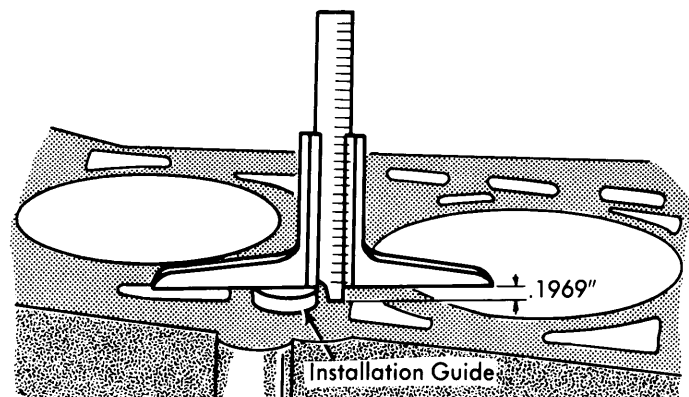

Fig. 3 Correct Procedure to Measure Cylinder Head Installation Guide

320i 4 CYLINDER (Cont.)

VALVES

VALVE ARRANGEMENT

Right Side – All exhaust.

Left Side – All intake.

ROCKER ARM ASSEMBLY

Removal – 1) With camshaft removed, push back thrust ring and rocker arm so rocker shaft circlip may be removed (See Fig. 4). Remove distributor mounting flange.

2) Drive out rocker shafts with a punch. Remove rocker arms, springs and thrust rings.

3) Replace rocker arm with loose slide pads.

NOTE – Rocker arm shaft on intake side is open. Exhaust rocker shaft is plugged.

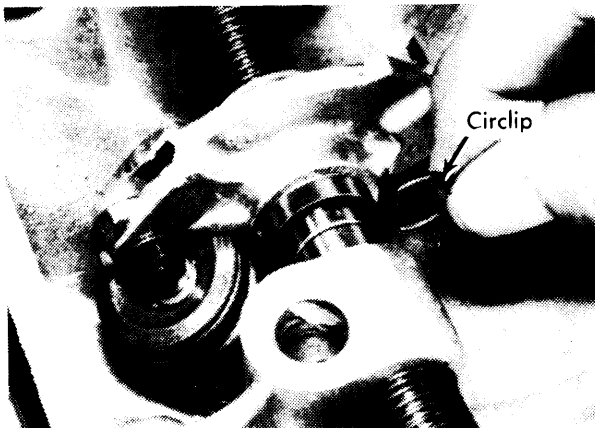

Fig. 4 Rocker Shaft Circlip Removal & Installation

Installation – Replace springs, rocker arms and thrust rings. Insert rocker shafts and align shafts so locating pins may be installed. Replace rocker shaft circlips.

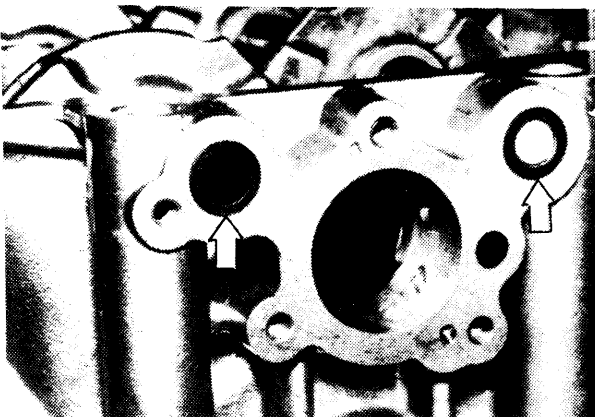

Fig. 5 View Showing Rear Exhaust Rocker Shaft Plugs

VALVE SPRING SERVICE

Remove valve keepers and collar. Check spring for wear or fatigue. Replace worn springs with green marked springs only. Install spring, collar and keepers.

VALVE GUIDE SERVICE

1) Check valve guide for wear. If replacement is necessary, press out guide toward combustion chamber. Measure guide bore in cylinder head. If bore exceeds .5512" (14 mm), ream head and install oversize guide.

2) Heat cylinder head to 428-482°F (220-250°C) and press in new guide from top side until tapered groove end protrudes .591" (15 mm) above surface. Ream guide to obtain specified clearance. Valve guides are available in the following sizes (O.D. measurements given):

Valve Guide Sizes

Application	Guide O.D. In. (mm)
Standard5532 (14.05)
1st Oversize5551 (14.10)
2nd Oversize5590 (14.20)
3rd Oversize5630 (14.30)

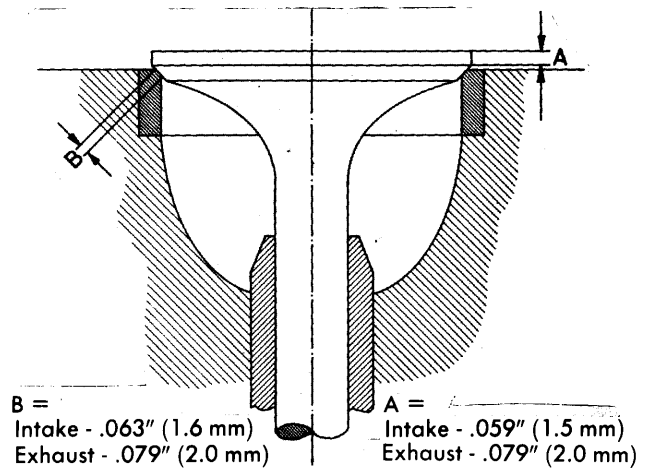

Fig. 6 Checking Valve Head & Seat Thickness

VALVE SEAT SERVICE

Refer to illustration and note minimum valve seat and valve head thicknesses. If either specification is not met, replace necessary component. When replacing valve seat, remove old seat by turning out with suitable cutting tool. Drill out bore to appropriate oversize; note valve seat oversize to be used and rebores head allowing for shrink-fit of replacement seat. When installing new seat, heat head to approximately 392°F (200°C) and chill valve seat to approximately -94°F

320i 4 CYLINDER (Cont.)

(-70°C). Replacement seats are available in the following oversizes:

Replacement Valve Seat Rings

Application	Measurement In. (mm)
Intake	
1st Oversize	1.864 (47.35)
2nd Oversize	1.872 (47.55)
Exhaust	
1st Oversize	1.589 (40.35)
2nd Oversize	1.596 (40.55)

VALVE CLEARANCE ADJUSTMENT

Adjust valves in firing order sequence (1-3-4-2) with No. 1 cylinder at TDC of compression stroke. Using a feeler gauge between rocker eccentric and valve stem, set clearance to .008-.010" (.20-.25 mm) with engine hot or to .006-.008" (.15-.20 mm) with engine cold. Loosen nut of rocker eccentric, insert a rod in eccentric hole and rotate until proper clearance is obtained (See Fig. 7).

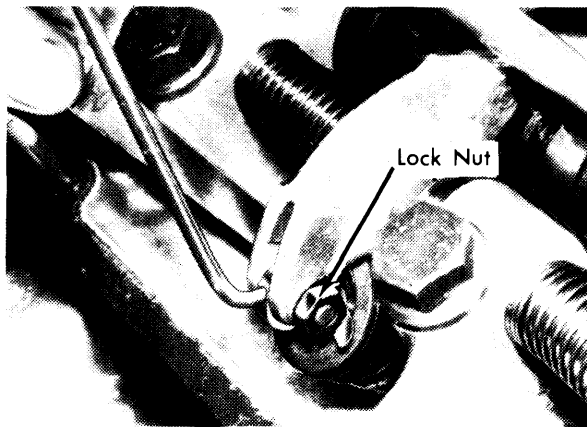

Fig. 7 Correct Procedure to Perform Tappet Adjustment

PISTONS, PINS & RINGS

OIL PAN

With engine installed, remove bolts securing steering to front axle carrier, move steering out of way. Drain oil, remove bolts securing oil pan, swing pan down. Turn crankshaft and remove oil pan. Coat crankcase ends where timing cover and rear main bearing cover join crankcase with sealing compound before reassembly.

PISTON & ROD ASSEMBLY

Removal — After removing oil pan and cylinder head, rotate crankshaft to TDC of piston and rod assembly to be removed. Unscrew connecting rod cap nuts and push assembly out top of engine. Replace worn or damaged parts as necessary, according to appropriate service procedure indicated in this article.

Installation — Place rings on piston with marking "TOP" facing upward and ring end gaps 180° apart. Install piston with arrow facing forward and oil hole in wrist pin end of connecting rod facing timing chain. Ensure connecting rod and bearing cap numbers match, with No. 1 rod nearest the timing chain.

CONNECTING ROD BUSHING

1) Remove circlips and push out wrist pin. Check for wear in piston and connecting rod. If rod bushing is worn, press out old bushing and press in new bushing with ends 90° to oil hole.

2) Wrist pins come in two diameters, white coded wrist pin with "W" stamped on piston crown or black coded wrist pin with "S" stamped on piston crown.

3) Drill oil holes in bushing and ream bushing diameter to specifications. Piston pin should be a light push fit through connecting rod bushing.

FITTING PISTONS

Piston crowns are marked with arrow for direction of installation and a "+", "-", or no sign to show weight classification. All pistons should have same weight mark. Measure piston and cylinder diameter to determine clearance (see specifications). Measure piston diameter at 90° to wrist pin bore near bottom of piston skirt, see following table for distance from bottom of piston.

Piston Measuring Location

Piston	In. (mm)
Mahle622 (15.8 mm)
KS923 (23.45 mm)

Piston Sizes

Application (Grade)	Diameter In. (mm)
Standard	3.5027 (88.97)
Intermediate	3.5059 (89.05)
No. 1 Oversize	3.5126 (89.22)
No. 2 Oversize	3.5224 (89.47)

CRANKSHAFT MAIN & CONNECTING ROD BEARINGS

MAIN BEARING SERVICE

Plastigage method is used to determine connecting rod and main bearing journal clearances. Standard or undersize crankshafts are marked red or blue. Color coded inserts must agree with crankshaft color code (See Figures 8 & 9). The following table shows color code and undersizes available:

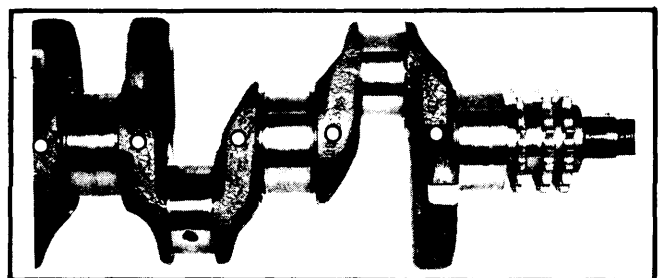

Fig. 8 View Showing Original Crankshaft Marks

320i 4 CYLINDER (Cont.)

Main Bearing Journal

Application	In. (mm)
Original	2.165 (55.0)
1st Stage	2.156 (54.75)
2nd Stage	2.146 (54.50)
3rd Stage	2.136 (54.25)

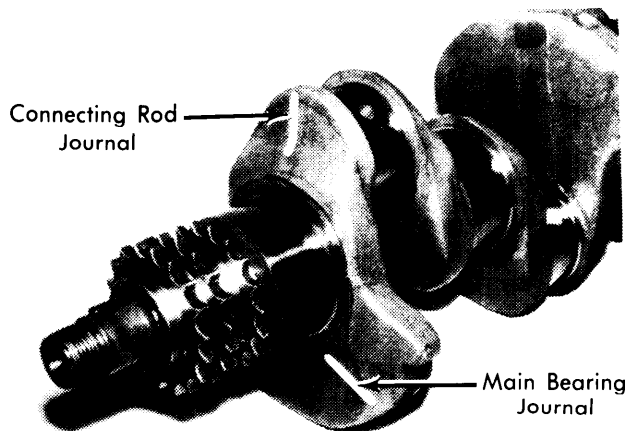

Fig. 9 View Showing Undersize Crankshaft Marks

Connecting Rod Journal

Application	In. (mm)
Original	1.889 (48.0)
1st Stage	1.879 (47.75)
2nd Stage	1.870 (47.50)
3rd Stage	1.860 (47.25)

THRUST BEARING ALIGNMENT

Attach a dial indicator to crankcase with shaft touching flywheel. Move flywheel in and out to determine endplay of crankshaft. If endplay is excessive, replace center main bearing inserts.

REAR MAIN BEARING OIL SEAL SERVICE

With flywheel removed, unscrew six attaching bolts from rear crankshaft seal holder. Carefully run a knife blade between seal holder and oil pan gasket to break seal. Remove seal holder and press out old seal, press in new seal. Coat oil pan gasket at either side with sealing compound and replace seal holder.

CAMSHAFT

ENGINE FRONT COVER & OIL SEAL

1) Remove radiator and loosen alternator adjusting brackets. Remove fan belt. Detach cover plate from transmission.

2) Using suitable tool (No. 11 2 100), lock flywheel ring gear. Unscrew nut from pulley hub and remove pulley. Using a suitable puller, extract oil seal and replace with new seal.

3) Remove bolts attaching timing cover. Insert a knife blade between cover and oil pan gasket to break seal. Lift off timing cover. To install, reverse removal procedures.

CAMSHAFT

Removal – 1) With cylinder head removed, loosen clamping screw and pull out distributor. Attach head assembly to a suitable holding tool (No. 11 1 040). Remove oil line and cold start valve.

2) Adjust valve clearance to maximum possible. Attach a suitable compression frame to preload the rocker assembly. Check end play between guide plate and camshaft. Remove guide plate and carefully withdraw camshaft.

Installation – 1) When replacing camshaft, note the following: After guide plate has been installed, it must be possible to easily rotate the camshaft. Make sure that notch in flange aligns with cast tab on cylinder head. Adjust valve clearances, note position of oil pipe sealing rings.

2) When replacing distributor, turn rotor counterclockwise by about 1.4" (3.5 mm) from notch in distributor housing, bring distributor drive into mesh with camshaft drive. Ensure vacuum advance has been located in original position. Adjust ignition timing.

TIMING CHAIN REPLACEMENT

Removal & Installation – 1) Remove distributor cap, set piston of No. 1 cylinder at TDC. Remove upper and lower timing case covers. Remove sprocket. Remove circlip and unscrew pivot pin until guide rail rests on cylinder head gasket. Remove timing chain from sprocket and crankshaft. Remove guide rail by pulling down and swinging to the right.

2) If timing chain sprockets need replacing. Remove oil pan, remove sprocket from oil pump. Remove timing chain. Remove sprocket with suitable puller (No. 11 2 000). To install: Heat sprocket, reverse removal procedure.

VALVE TIMING

Rotate engine to TDC of No. 1 piston. Position camshaft so that timing mark on camshaft flange is straight up and locating pin hole is straight down. Without moving crankshaft or camshaft, install camshaft sprocket so that it engages locating pin hole in camshaft flange.

TIMING CHAIN TENSIONER SERVICE

NOTE – Chain tensioner is correct if chain gives under slight thumb pressure.

1) Unscrew tensioner plug and remove piston and spring.

CAUTION – Tensioner plug is under high spring pressure, use care when removing plug.

2) Press piston out of sleeve. Remove ball bearing and perforated disc. Clean all parts thoroughly.

320i 4 CYLINDER (Cont.)

3) Reassemble sleeve, perforated disc, ball bearing and piston, making sure perforated disc does not block bleed slots (See Fig. 10).

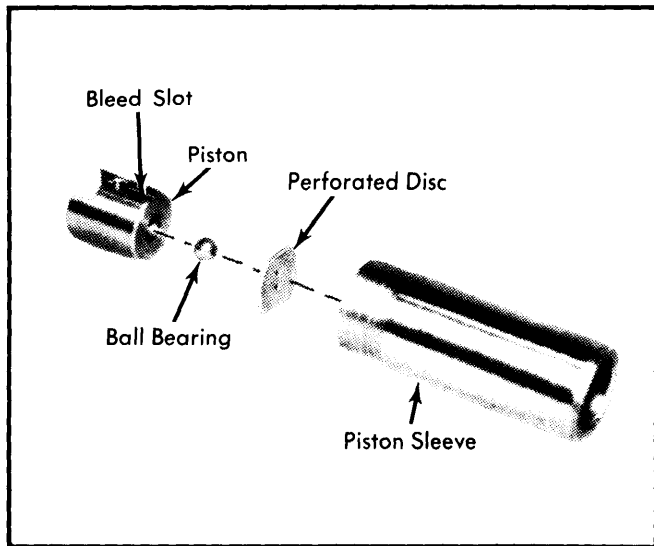

Fig. 10 Exploded View of Chain Tensioner Piston Assembly

4) Install piston in tensioner body. Place spring with tapered end facing tensioner plug. Screw tensioner plug slightly into tensioner body. Fill oil pocket with engine oil and move tensioner rail back and forth until oil comes out around plug threads. Tighten tensioner plug.

4) Using suitable puller, remove drive flange from rotor shaft. Press drive flange on new rotor shaft to a distance of 1.68" (42.7 mm) between flange and rotor face (See Fig. 11).

5) To install, reverse removal procedure, noting the following if replacing a gear-type pump with a rotor-type pump: Install a 46-link drive chain, and adjust chain tension so that chain can be depressed with light thumb pressure. Compensating plates are available for insertion between block and pump mounting if chain tension cannot be correctly set. Change upper section of oil filter mounting as rotor-type pump requires larger pressure relief valve opening.

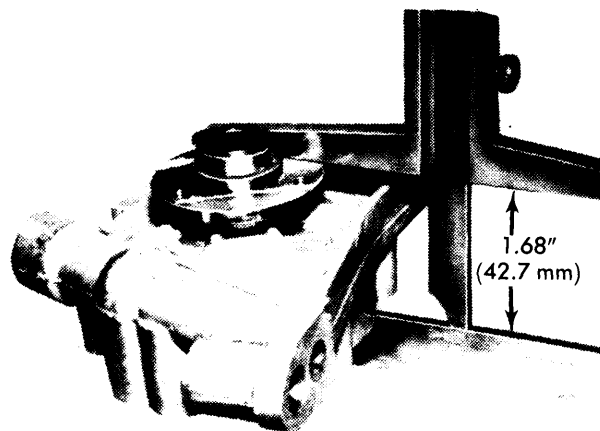

Fig. 11 Measuring Distance Between Flange and Rotor Face

NOTE — When installing compensating plate between oil pump and crankcase make sure oil hole is in proper position.

ENGINE OILING

ENGINE OILING SYSTEM

A chain driven rotor type oil pump pressure feeds oil to a full-flow oil filter. From oil filter, oil is circulated through passages to all moving parts of the engine.

Crankcase Capacity — 4.5 qts. (4.25 liters) with filter
Oil Filter — Full-Flow
Oil Pressure — 57psi@4000RPM
Pressure Regulator Valve — Non-adjustable

OIL PUMP

1) Remove oil pan and oil pump sprocket. Remove bolts attaching pump pick-up. Remove two bolts mounting pump to crankcase and lift out pump.

2) Unscrew union and remove spring and plunger from pump body. Remove pick-up tube and cover from pump body.

3) Measure clearance between outer rotor-to-pump body, rotor-to-rotor and rotor face-to-pump body flange (see specifications).

Oil Pump Specifications

Application	Measurement In. (mm)
Rotor-to-Housing0014-.0043 (.04-.11)
Inner-to-Outer Rotor0047-.0079 (.12-.20)
Cover-to-Rotor0039-.0059 (.10-.15)
Press. Relief Spring (Free Length)	2.68 (68.1)

ENGINE COOLING

Thermostat — Opens at 176°F (80°C).
Cooling System Capacity — 7.4 qts. (7 liters)

WATER PUMP

1) Loosen alternator bracket. Remove fan and drive belt. Loosen hose clamps and remove water pump.

2) Using a suitable puller, remove fan hub from impeller shaft. Extract circlip and spacer ring from front of pump.

3) Press impeller off shaft and pump bearing out of housing. Drive friction seal out of housing and lift out cover ring.

BMW Engines

320i 4 CYLINDER (Cont.)

4) Replace any worn or damaged parts. Using suitable tool, press impeller onto shaft until there is clearance of .031-.047" (.79-1.2 mm) between impeller and pump face.

5) Press fan hub onto pump shaft until a distance of 2.96-2.97" (75.1-75.5 mm) exists between hub flange and pump face (See Fig. 16). To install, reverse removal procedure.

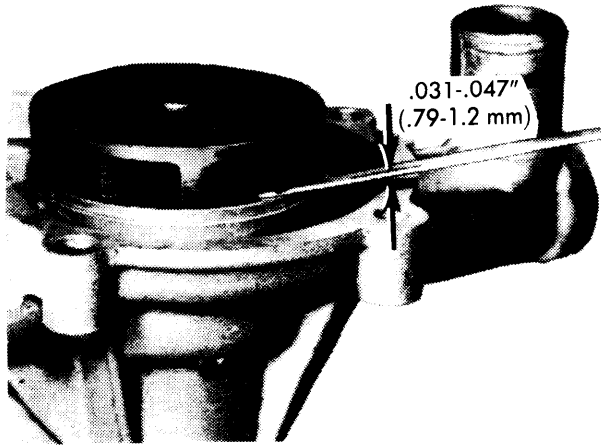

Fig. 12 Measuring Clearance Between Water Pump Impeller and Pump Face

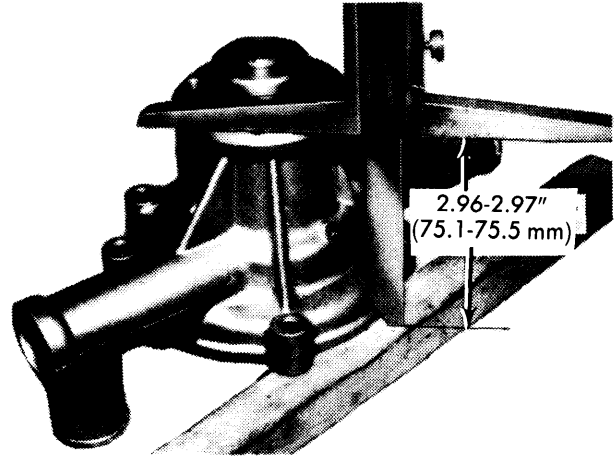

Fig. 13 Measuring Clearance Between Hub Flange and Pump Face

ENGINE SPECIFICATIONS

GENERAL SPECIFICATIONS										
Year	Displ.		Carburetor	HP at RPM	Torque (Ft. Lbs. at RPM)	Compr. Ratio	Bore		Stroke	
	cu. ins.	cc					in.	mm	in.	mm
1977	121.4	1990	Fuel Inj.	①110@5800	②112@3750	8.1:1	3.504	89	3.150	80

- ① - Calif. 105@5800
- ② - Calif. 108.5@3750

VALVES							
Engine & Valve	Head Diam. In. (mm)	Face Angle	Seat Angle	Seat Width In. (mm)	Stem Diameter In. (mm)	Stem Clearance In. (mm)	Valve Lift In. (mm)
320i Intake	1.805 (45.84)	45° 30'	46°	.059-.083 (1.50-2.10)	.3134-.3139 (7.960-7.975)	.0010-.0020 (.025-.055)
Exhaust	1.490 (37.84)	45° 30'	46°	.061-.081 (1.55-2.05)	.3129-.3134 (7.945-7.960)	.0015-.0030 (.040-.070)

VALVE SPRINGS			
Engine	Free Length In. (mm)	PRESSURE Lbs. @ In. (kg @ mm)	
		Valve Closed	Valve Open
320i	1.712 (43.5)	64@1.48 (29@37.6)	154@1.12 (70@28.5)

VALVE TIMING				
Engine	INTAKE		EXHAUST	
	Open (BTDC)	Close (ALDC)	Open (BLDC)	Close (ATDC)
320i	18°	66°	66°	18°

320i 4 CYLINDER (Cont.) ENGINE SPECIFICATIONS (Cont.)

PISTONS, PINS, RINGS						
Engine	PISTONS	PINS		RINGS		
	Clearance In. (mm)	Piston Fit In. (mm)	Rod Fit In. (mm)	Rings	End Gap In. (mm)	Side Clearance In. (mm)
320i	.0018 (.045)	①.0008-.0024 (.002-.006)	.0001-.0004	No.1	①.0118-.0177 (.30-.45)	.0024-.0036 (.06-.092)
				No.2	.008-.016 (.20-.40)	②.0016-.0028 (.040-.072)
				No.3	.010-.020 (.25-.50)	②.0012-.0024 (.030-.062)

- ① — Mahle Pistons — .0004-.0020 (.001-.005)
 ② — Mahle Pistons No. 2 .0012-.0024 (.030-.062)
 No. 3 .0008-.0020 (.020-.052)

CRANKSHAFT MAIN & CONNECTING ROD BEARINGS							
Engine	MAIN BEARINGS				CONNECTING ROD BEARINGS		
	Journal Diam. In. (mm)	Clearance In. (mm)	Thrust Bearing	Crankshaft End Play In. (mm)	Journal Diam. In. (mm)	Clearance In. (mm)	Side Play In. (mm)
320i Red	2.165 (55.0)	.0004-.0008 (.010-.020)	Center	.0033-.0068 (.085-.174)	1.8878-1.8885 (47.95-47.966)	.0009-.0027 (.023-.069)
	Blue	2.165 (55.0)			.0008-.0011 (.020-.029)	1.8878-1.8885 (47.95-47.96)	

CAMSHAFT			
Engine	Journal Diam. In. (mm)	Clearance In. (mm)	Lobe Lift In. (mm)
2002 ①			
No. 1	1.3764-1.3772 (34.96-34.98)	.0013-.0029 (.033-.074)	.2764 (7.02)
No. 2	1.6520-1.6528 (41.96-41.98)	.0013-.0029 (.033-.074)	.2764 (7.02)
No. 3	1.6913-1.6921 (42.96-42.98)	.0013-.0029 (.033-.074)	.2764 (7.02)

① — End play is .0008-.005" (.020-.127 mm).

TIGHTENING SPECIFICATIONS	
Application	Ft. Lbs. (mkg)
Cylinder Head Studs ①	
Step 1	25-33 (3.5-4.5)
Step 2	43-47 (6.0-6.5)
Step 3	49-52 (6.8-7.2)
Main Bearing Caps	42-46 (5.8-6.3)
Connecting Rod Bolts	38-41 (5.2-5.7)
Flywheel-to-Crankshaft ②	76-83 (10.5-11.5)
Rocker Arm Lock Bolts	7-8 (0.9-1.1)
Oil Pan Bolts	7-8 (0.9-1.1)
Camshaft Oiler (Hollow Bolt)	8-9 (1.1-1.3)
Crankshaft Pulley	101-108 (14-15)
Fuel Pump	7-10 (1.0-1.4)
Timing Cover	7-18 (0.9-2.5)

① — With engine at normal operating temperature.
 ② — Coat bolts with Loctite.