

TRIUMPH TR7

Triumph TR7

DESCRIPTION

Rear axle is hypoid design with center line of pinion set below centerline of ring gear. The axle shafts, pinion and differential assembly can be serviced without removing axle housing from vehicle. Drive pinion bearing preload is maintained by a collapsible spacer. All other differential adjustments are made using selected shims. Adjustment of axle shaft end play is not required.

AXLE RATIO & IDENTIFICATION

Only one basic axle design is used. To determine axle ratio, divide number of ring gear teeth by number of pinion gear teeth.

REMOVAL & INSTALLATION

DRIVE AXLE HOUSING ASSEMBLY

Removal – 1) Place jack under rear axle, raise vehicle, and support body securely on stands.

2) Remove rear wheels. Disconnect propeller shaft at rear axle and disconnect forward end of flexible rear brake hose. Disconnect handbrake cable at backplate, then remove bolt and nut securing handbrake adjusting cable compensator to rear axle housing.

3) Disconnect rear shock absorbers at axle housing bracket. Lower jack and remove rear springs. Remove bolts and nuts securing radius rods to axle and detach handbrake cable bracket from left side.

4) Release radius rods from axle brackets, then lift axle clear of suspension arms and anti-roll bar and remove from vehicle.

Installation – To install, reverse removal procedure and bleed brakes.

AXLE SHAFTS & BEARINGS

Removal – 1) With rear of vehicle raised and wheel removed, remove axle shaft nut and washer. Remove screws retaining brake drum and remove drum. Withdraw rear hub from axle shaft using suitable puller. Disconnect handbrake cable and brake pipe. Remove nuts, washers and bolts retaining brake backplate to axle housing.

2) Note installed position of drip lip in relation to brake slave cylinder and remove oil catcher and backplate assembly. Remove rear hub oil seal and housing assembly. Remove oil seal from housing using suitable tool. Remove axle shaft key and place container under axle to collect oil spillage. Withdraw axle shaft from housing, using suitable puller. Remove inner oil seal and press bearing from axle shaft.

Installation – 1) Pack bearing with lithium based grease and dip inner oil seal in light oil. Install new oil seal with lip of seal facing inward. Press bearing onto axle shaft.

2) Maintain a minimum clearance of .16" (4.1 mm) between bearing and axle shaft collar.

2) Install axle shaft, hub seal housing and gasket, backplate and oil catcher. Make sure oil drain holes align with axle housing flange.

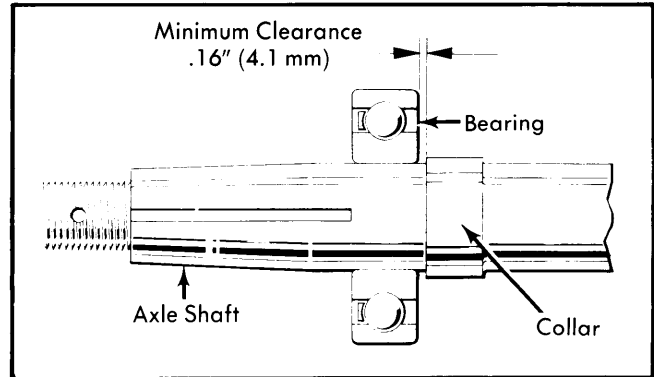

Fig. 1 Axles Shaft Bearing Clearance

3) For remaining components, reverse removal procedures, noting the following: Tighten axle shaft nut to specifications and bleed brakes.

PINION FLANGE & SEAL

Removal – 1) Raise and support vehicle. Mark propeller shaft and pinion flanges for correct realignment. Disconnect propeller shaft and remove flange nut shield, nut, and cotter pin.

2) Mark flange, pinion shaft, and nut, then holding flange stationary, remove nut and washer (noting number of turns to remove nut). Remove flange and oil seal.

Installation – 1) To install, reverse removal procedures and note the following: Soak new seal in light oil for one hour before installing. Install seal with lip of seal facing inward.

2) Align index mark on flange and shaft and tighten nut the same number of turns required to remove it. Finish tightening nut until index marks are aligned.

DIFFERENTIAL CARRIER

Removal – 1) Remove both axle shafts and mark differential pinion and propeller shaft for proper realignment on assembly. Disconnect propeller shaft.

2) Place container under axle assembly to collect oil, then remove nuts and washers retaining carrier to axle housing. Remove carrier.

Installation – To install, reverse removal procedure noting the following: Use new gasket and apply gasket sealer. Refill axle with lubricant.

OVERHAUL

DISASSEMBLY

1) With carrier removed, mount unit upright in a vise and mark bearing caps for correct reassembly. Remove bearing cap bolts, washers and caps. Assemble suitable axle stretcher (18G-131) on unit casing and stretch unit case by tightening turnbuckle three or four flats until differential carrier can be levered out and bearing shims and caps removed. **CAUTION** – To avoid damaging case, do not spread any more than necessary. Maximum stretch is .008" (.20 mm). Do not pry against stretcher.

TRIUMPH TR7 (Cont.)

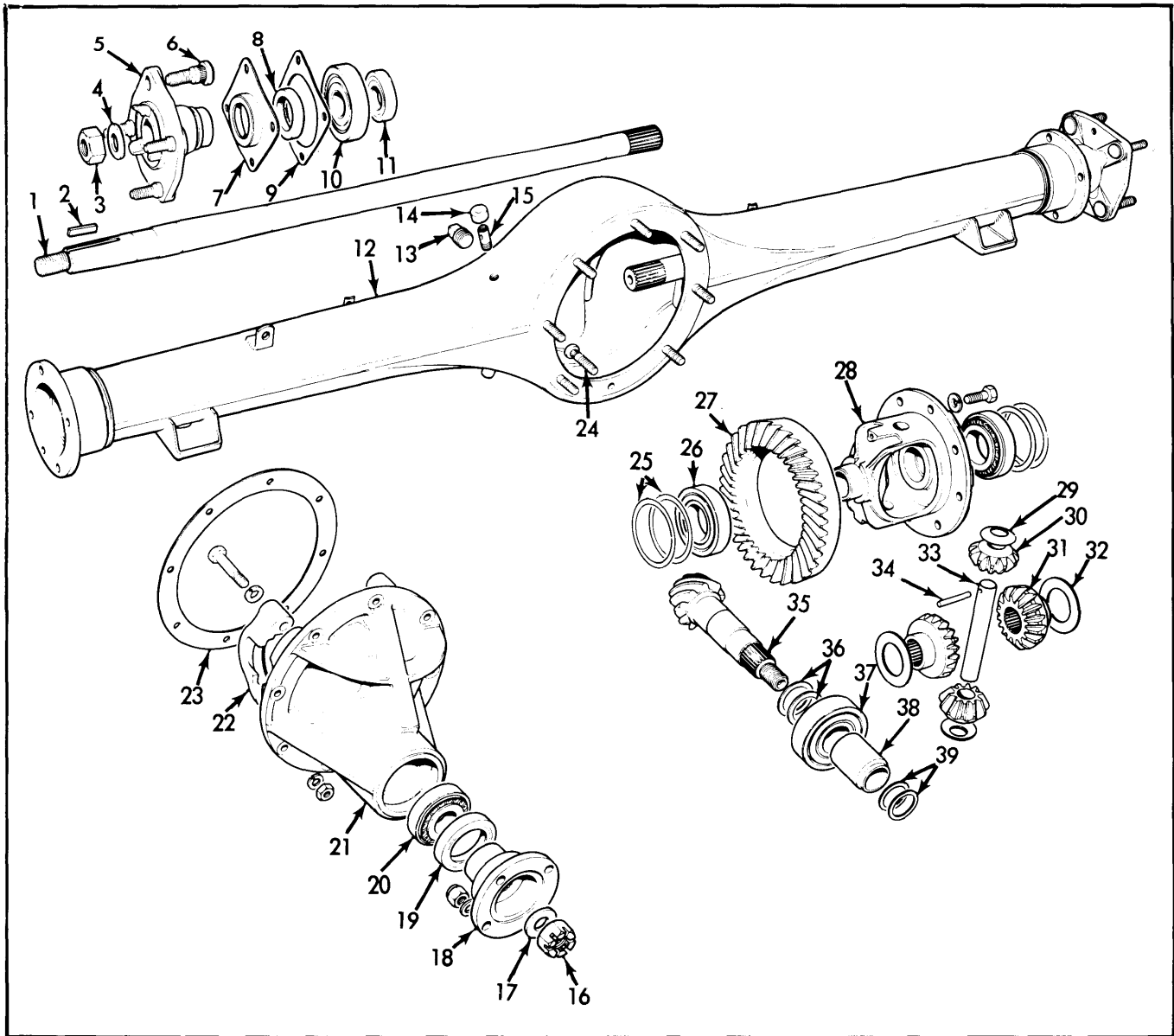

- | | | |
|------------------------|---------------------------------|---------------------------------|
| 1 - Axle Shaft | 14 - Vent Cap | 27 - Ring Gear |
| 2 - Axle Shaft Key | 15 - Vent Valve | 28 - Gear Carrier |
| 3 - Axle Shaft Nut | 16 - Pinion Nut | 29 - Thrust Washer |
| 4 - Axle Shaft Washer | 17 - Pinion Washer | 30 - Differential Pinion Gear |
| 5 - Rear Hub | 18 - Pinion Drive Flange | 31 - Differential Side Gear |
| 6 - Lug Bolt | 19 - Oil Seal | 32 - Thrust Washer |
| 7 - Oil Seal Housing | 20 - Drive Pinion Outer Bearing | 33 - Pinion Gear Shaft |
| 8 - Oil Seal | 21 - Carrier Housing | 34 - Locking Pin |
| 9 - Gasket | 22 - Carrier Bearing Cap | 35 - Drive Pinion Gear |
| 10 - Rear Axle Bearing | 23 - Gasket | 36 - Shims |
| 11 - Oil Seal | 24 - Housing Stud | 37 - Drive Pinion Inner Bearing |
| 12 - Rear Axle Housing | 25 - Bearing Shims | 38 - Bearing Spacer |
| 13 - Drain Plug | 26 - Differential Bearing | 39 - Shims |

Fig. 2 Exploded View of Triumph TR7 Drive Axle Assembly

TRIUMPH TR7 (Cont.)

2) Remove gear carrier bearing caps and mark ring gear and carrier to ensure correct replacement. Remove ring gear retaining bolts and ring gear. Drive out pinion shaft locking pin, then drive out pinion shaft. Remove pinion gears and thrust washers. Remove differential gears and thrust washers. Remove drive flange nut cotter pin and drive flange nut. Using suitable puller, remove drive flange.

3) Press out drive pinion and remove pinion bearing collapsible spacer and washer. Using suitable press tools, remove inner bearing from pinion. Remove pinion head washer and drive out pinion outer bearing race, bearing, and seal. Drive out pinion inner bearing race.

INSPECTION

Clean and inspect all components for wear or damage. Ring and pinion gears, differential bearings and pinion bearings must be replaced as matched sets.

REASSEMBLY & ADJUSTMENT

Side Bearing Preload – 1) Install differential bearing cones in gear carrier using suitable tool. Install two differential gears in carrier, ensuring each thrust washer is correctly positioned. Position two pinion gears, one each side of carrier and mesh them with differential gears. Using an axle shaft inserted in a differential gear, turn gears and ensure two pinions rotate into mesh and align with pinion shaft hole in carrier. Install pinion shaft.

2) Press each pinion firmly into mesh with differential gears and assess required pinion thrust washer thickness required to achieve ZERO backlash. Remove pinion shaft and pinions and install thrust washers. Reinstall pinion gears and shafts with thrust washers and check that zero backlash exists. Lubricate components and install pinion shaft locking pin and secure by peening metal of differential carrier.

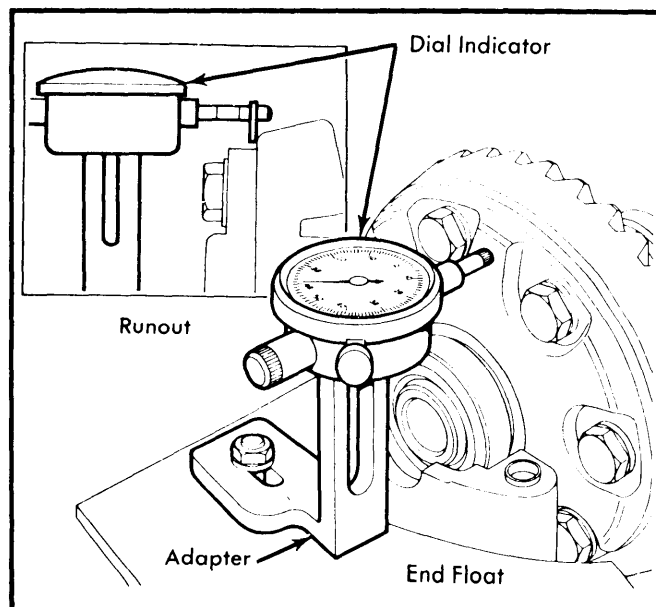

Fig. 3 Checking Ring Gear Runout and Total Side Float

3) Clean ring gear mounting and carrier face and install ring gear, tighten bolts. Assemble carrier bearing cups to bearings and position assembly in case; do not install bearing shims. Install bearing caps in correct position. Using dial indicator and suitable adapters, ensure that ring gear runout does not exceed specifications. Remove bearing caps and press differential bearing cups onto bearings and move carrier assembly to one side of case. Zero dial indicator and move carrier assembly fully in opposite direction. The indicator reading should be noted for future reference as "Total Side Float". Remove differential assembly from case.

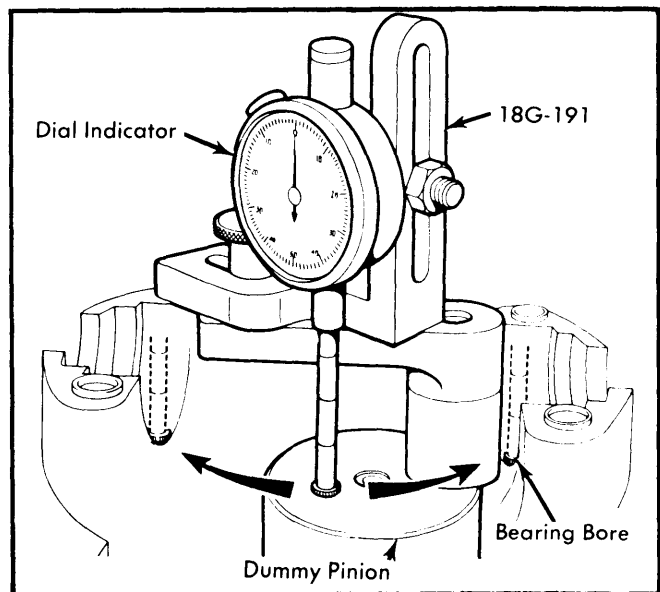

Fig. 4 Checking Drive Pinion Gear Depth

Drive Pinion Depth – 1) Install inner and outer pinion bearing cups to case using suitable tools. Install pinion inner bearing to dummy pinion (18G-191 M). **NOTE** – Dummy pinion incorporates standard pinion head washer of .077" (1.95 mm) thickness. Oil bearing and install dummy pinion, outer bearing, tool spacer, washer and nut. Tighten nut gradually until bearing preload specification is obtained. Clean dummy pinion head and position dial indicator gauge foot of tool 18G-191 on dummy head and zero indicator.

2) Move dial indicator over center of one differential bearing bore and note reading. Repeat for opposite bearing bore. Average these two measurements and perform the following calculation:

EXAMPLE:

Average of bore measurements002" (.051 mm)
PLUS dummy pinion washer allowance077" (1.956 mm)
Required size of pinion head washer.....	.079" (2.007 mm)

If the etched marking on pinion face is an "N" or a dot ".", indicating normal, no change to above dimension is required. If etched marking is positive (+), reduce size of required pinion washer by amount marked. If etched marking is negative (-) increase size of required pinion washer by amount marked. Remove dummy pinion and remove inner bearing from dummy pinion.

TRIUMPH TR7 (Cont.)

Pinion Bearing Preload With Spacer and Shims – 1) Place selected pinion depth washer on pinion and install inner bearing using suitable tools. Oil bearing and install drive pinion gear in housing. Install bearing spacer, chamfered end towards drive flange. Install shims, oil and install outer bearing. Install drive flange washer and nut. Gradually tighten nut, but do not exceed torque specification, and check preload during tightening operation.

2) Rotate flange to settle bearing and check preload with flange nut tightened to specifications. If preload is high, increase shim thickness. If preload is low, decrease shim thickness. **NOTE** – .001" shim thickness equals approximately 4 INCH lbs. (4.6 cmkg) preload. Remove drive flange nut and flange. Soak new oil seal in oil for one hour and then install seal. Install drive flange, washer and nut and tighten flange nut. Install new cotter pin.

Pinion Bearing Preload With Collapsible Spacer – 1) Place selected pinion depth washer on pinion and install inner bearing onto pinion using suitable tools. Oil bearing and install drive pinion gear in housing. Install collapsible spacer and outer pinion bearing on pinion shaft. Install oil seal with lips of seal towards pinion gear head. Install flange, washer, and nut, but do not tighten nut.

2) While gradually tightening nut, keep checking the pinion bearing preload using an inch pound torque wrench. Tighten nut as required to obtain specified pinion bearing preload. **NOTE** – If pinion bearing preload torque specification is exceeded, a new collapsible spacer will be required and this procedure repeated.

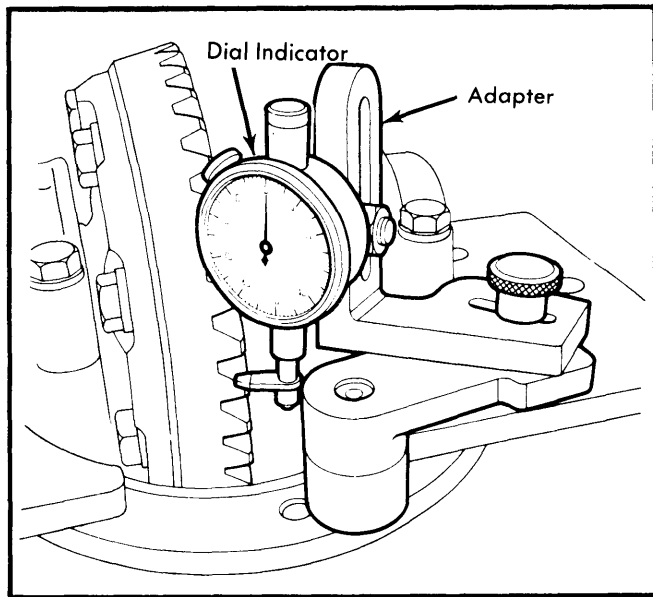

Fig. 5 Checking Ring Gear-to-Drive Pinion Gear Backlash

Adjusting Backlash – 1) Place bearing cups on differential bearing and install carrier in case. Position dial indicator with suitable adapters on ring gear side of case. Move ring gear fully into mesh with pinion and zero indicator on rear of ring gear. Move ring gear and carrier in opposite direction until bearing ring gear side is butted in housing. The indicated measurement should be noted as the "In-Out" mesh clearance.

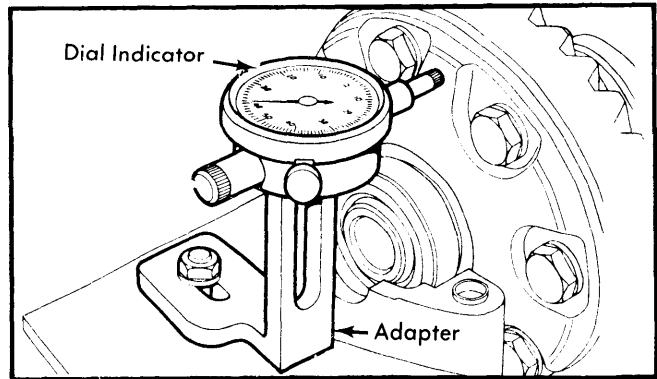

Fig. 6 Checking Ring Gear-to-Drive Pinion "In-Out" Mesh Clearance

2) Perform the following calculation:

EXAMPLE:

"In-Out" mesh clearance ^①025" (.63 mm)
MINUS Specified backlash005" (.13 mm)
Required ring gear side shim pack020" (.50 mm)
"Total Side Float" ^②060" (1.52 mm)
MINUS ring gear side shim pack.....	.020" (.50 mm)
Required shim pack opposite ring gear040" (1.02 mm)

① – Value from 1) above.

② – Value from 3) under "Side Bearing Preload".

Add a value of .002" (.51 mm) to each shim pack calculated above for preload.

3) Stretch case specified amount and from calculations made above, select required shim pack. Install differential assembly in case with shim packs. Loosen case stretcher and remove. Install bearing caps as originally marked and tighten bolts. Rotate pinion to settle differential bearings and position dial indicator using suitable adapters to measure ring gear backlash. Measure backlash at several locations, it must be to specifications. If not, interchange shims from side to side to achieve specified backlash. **NOTE** – A movement of .002" (.05 mm) shim thickness from one bearing to the other will vary backlash by about .002" (.05 mm). Reinstall differential assembly in rear axle housing.

TIGHTENING SPECIFICATIONS

Application	Ft. Lbs. (cmkg)
Carrier-to-Axle Housing	15-20 (2.0-2.8)
Axle Shaft Nut	90-120 (12.4-16.6)
Bearing Cap Bolts	30-38 (4.1-5.3)
Ring Gear Attaching Bolts	38-46 (5.3-6.4)
Wheel Nuts	60-75 (8.3-10.4)
Propeller Shaft Flange Bolts	26-34 (3.6-4.7)
Brake Back Plate Nuts	10-14 (1.4-1.9)

AXLE ASSEMBLY SPECIFICATIONS

Ring Gear Runout003" (.076 mm)
Pinion Bearing Preload ...	13-20 INCH Lbs. (11-27 cmkg)
Ring Gear Backlash005±.001" (.13±.02 mm)