



## DATSUN INTEGRAL HOUSING (I.R.S.) (Cont.)

shaft outer flange stationary. Using suitable axle stand (ST07640000) and slide hammer, remove axle shaft. Remove wheel bearing spacer, companion flange and bearing washer, then remove inner wheel bearing and oil seal. Remove grease catcher, then press or pull outer wheel bearing from axle shaft. **NOTE** — Do not reuse old outer wheel bearing.

**Installation** — To install, reverse removal procedure and note the following: Clean and inspect all parts for wear or damage and replace as necessary. Grease wheel bearings and housing before installation. When installing bearings ensure outer bearing is installed with seal towards wheel and that inner bearing is installed with seal facing differential. A mark "A", "B" or "C" is stamped on axle housing. Ensure that bearing spacer with same mark is installed. Tighten all bolts and nuts and adjust wheel bearings.

**Wheel Bearing Adjustment** — After tightening wheel bearing lock nut to specification, check that axle shaft end play is .006" (.15 mm) or less. Check that turning torque of axle shaft is less than 1.8 lbs. (.8 kg) at hub bolt. If either adjustment is not to specification, disassemble axle shaft assembly and replace bearing spacer.

### DRIVE SHAFTS

**Removal & Installation** — Raise and support rear of vehicle on safety stands. Disconnect drive shaft from axle shaft companion flange. Remove differential side yoke attaching bolt and lift out side yoke and drive shaft as an assembly. To install, reverse removal procedure and note the following: Exercise care when installing assembly to prevent damage to side yoke and oil seal. Tighten all bolts to specifications.

### PINION FLANGE & OIL SEAL

**Removal** — Drain gear oil from differential, then raise and support rear of vehicle. Disconnect propeller shaft from pinion flange, then if necessary remove muffler and disconnect parking brake cable. On 280Z remove rear stabilizer from vehicle. On all models, remove pinion nut while holding pinion flange stationary. Using a suitable puller remove pinion flange. Remove oil seal using suitable puller (ST33290001).

**Installation** — To install, reverse removal procedure and note the following: Apply suitable grease between seal lips before installation. Tighten pinion nut to specifications and ensure pinion bearing preload is correctly adjusted. Fill differential to proper level with gear oil.

### AXLE ASSEMBLY

**Removal** — Raise and support rear of vehicle. On 280Z remove main muffler. On all models disconnect propeller shaft from axle assembly. On 280Z remove axle drive shafts by separating them from retaining flanges. On 610 models, remove side retainer flange bolt and remove side retainers with drive shafts. Support axle assembly on a jack, then remove nuts on both ends of axle assembly rear mounting member. Remove axle assembly front mount attaching bolts, lower assembly on jack and remove from vehicle. **NOTE** — On 610 models, support suspension member to prevent damage to insulators.

**Installation** — To install, reverse removal procedure and note the following: Install same size mounting spacer between axle assembly and front mount. Tighten all nuts and bolts to specifications and fill assembly to correct level with gear oil.

## DRIVE SHAFT OVERHAUL

### DISASSEMBLY

**NOTE** — Drive shaft should be disassembled only to lubricate ball spline.

Remove universal joint from differential end of drive shaft. Remove snap ring from sleeve yoke plug and remove plug. Compress drive shaft and remove snap ring from stopper, then remove stopper. Disconnect boot and separate drive shaft carefully so as not to lose balls and spacers.

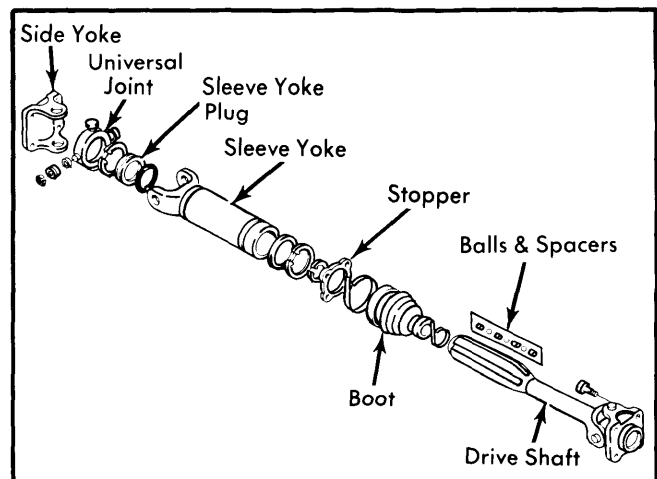

Fig. 2 Exploded View of Drive Shaft Assembly

### INSPECTION

Check rubber boot and oil seals for damage and replace as necessary. Inspect drive shaft for straightness, cracks, damage and distortion and replace drive shaft if necessary. Check all other drive shaft components for wear, damage and distortion and replace complete drive shaft assembly if any faulty part is found. Check drive shaft play as shown in illustration and replace complete assembly if play exceeds .004" (1 mm).

**NOTE** — Measurement should be taken with drive shaft fully compressed.

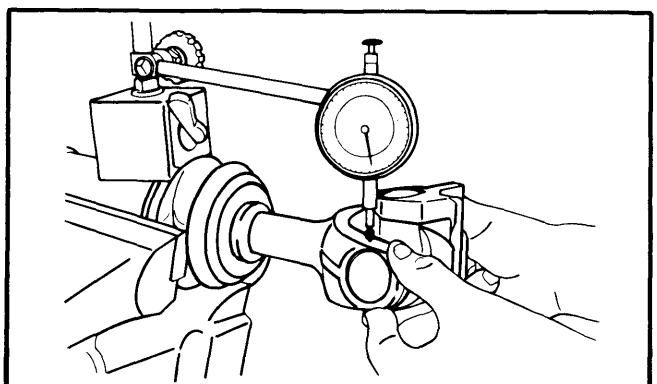

Fig. 3 Measuring Play in Drive Shaft

## DATSUN INTEGRAL HOUSING (I.R.S.) (Cont.)

## REASSEMBLY

To reassemble, reverse disassembly procedure and note the following: Align yokes and ensure steel balls and spacers are installed in correct order. Adjust axial play of universal joint to within .0008" (.02 mm) by selecting proper size snap ring. **NOTE** — Snap rings are available in four sizes: .0587" (1.49 mm); .0598" (1.52 mm); .0610" (1.55 mm); .0622" (1.58 mm). Apply grease to ball grooves and oil grooves.

## AXLE ASSEMBLY OVERHAUL

## DISASSEMBLY

1) Mount axle assembly on suitable holding fixture. Remove rear mounting member and axle assembly cover plate. Using suitable puller, remove side retainers and shims (610), or side flange, bearing cap screws, caps and shims (280Z). **NOTE** — Mark retainers or bearing caps and shims for reassembly. Left and right sides are not interchangeable. If side bearings on the 610 model are to be replaced, remove bearing outer race from side retainer using a suitable puller.

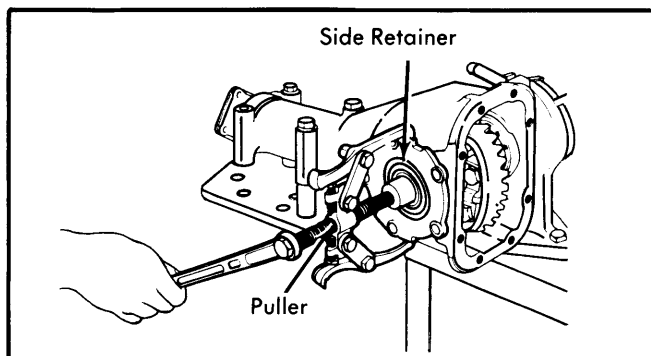

Fig. 4 Removing Side Retainer (610 Model)

2) Hold pinion flange stationary and remove pinion nut, then using suitable puller, remove pinion flange. Press drive pinion from carrier and remove rear bearing inner race, bearing spacer and adjusting washers. Remove oil seal. Remove pilot bearing together with pilot bearing spacer and front bearing inner race. Press rear bearing inner race from drive pinion. Using a drift, remove front and rear bearing outer races.

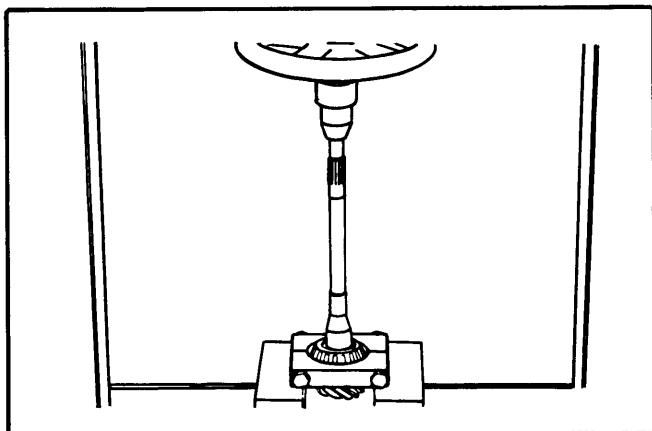

Fig. 5 Removing Pinion Gear Bearing Inner Race

3) To disassemble differential case, use suitable puller and remove side bearings. **NOTE** — Keep left and right side bearings separate, they are not interchangeable. Remove ring gear by unfolding lock strap and loosening bolts. Punch off pinion shaft lock pin from ring gear side, then remove pinion shaft, pinion gears, side gears and thrust washers. **NOTE** — Mark gears and thrust washers for installation in their original position. Thoroughly clean and inspect all parts for wear or damage and repair or replace as necessary.

## REASSEMBLY &amp; ADJUSTMENT

**Differential Case Assembly** — 1) Assemble pinion gears, side gears and thrust washers in original positions in differential case. Fit pinion shaft to differential case so that it aligns with lock pin holes. Adjust side gear-to-pinion gear backlash or adjust clearance between rear face of side gear and thrust washer. Install pinion shaft lock pin and lock in place with punch.

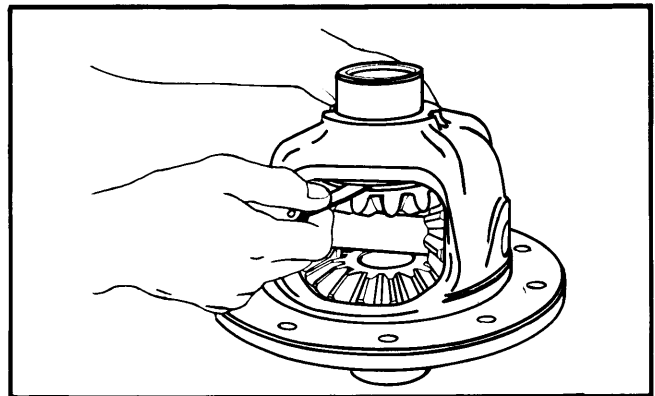

Fig. 6 Measuring Side Gear Clearance

2) Apply gear oil to gear tooth surface and thrust surfaces and ensure gears rotate smoothly. Install ring gear on differential case and install bolts and new lock washers. **NOTE** — Tighten ring gear bolts diagonally while tapping around bolt heads with a hammer.

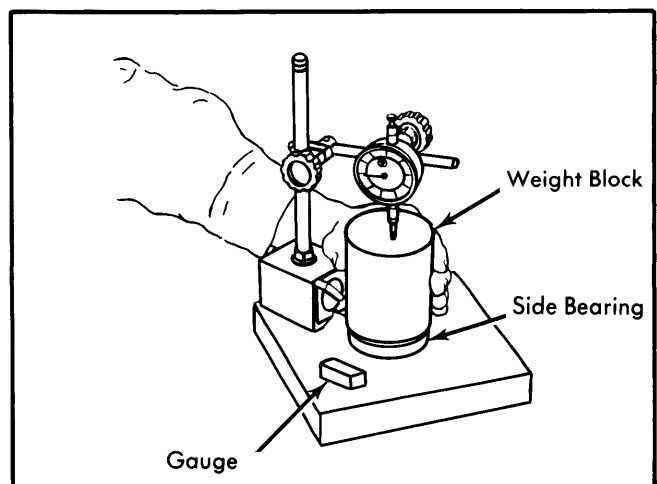

Fig. 7 Measuring Side Bearing Width

## DATSUN INTEGRAL HOUSING (I.R.S.) (Cont.)

3) When replacing side bearings, measure bearing width with a .787" (20 mm) gauge and a 5.5 lb. (2.5 kg) weight block. Bearing width should be slightly smaller than gauge. Press fit side bearing inner race on differential case and side bearing outer race into side retainers. Install new oil seal on side retainer and apply grease to cavity between seal lips.

**Drive Pinion Bearing Preload Adjustment** – 1) Install front and rear bearing outer races into carrier. Install dummy pinion shaft (ST31212000 – 610 Series; KV38100110 – 280Z) with rear bearing and original pinion depth washer between bearing and pinion head. **NOTE** – If ring and pinion gear tooth contact pattern was incorrect at time of disassembly, use a new pinion depth washer of .121" (3.09 mm) thickness.

2) Install pinion bearing preload spacer and washer, front bearing cone, drive pinion dummy collar (ST31214000 – 610 Series; KV38100130 – 280Z), companion flange, and nut onto dummy shaft. Do not install oil seal at this time. Tighten nut to specified torque. **NOTE** – Replace preload spacer and washer with thicker ones if pinion shaft can not be turned by hand during entire process of tightening nut.

3) Using an inch pound torque wrench, check rotating torque of pinion shaft. If preload is not within specification, install thicker adjusting washer to decrease preload torque or thinner washer to increase preload torque. **NOTE** – Washers are available in thicknesses from .0906" to .1024" (2.30 mm to 2.60 mm), and spacers are available in lengths from 2.2126" (56.20 mm) to 2.2520" (57.20 mm) in increments of .008" (.20 mm).

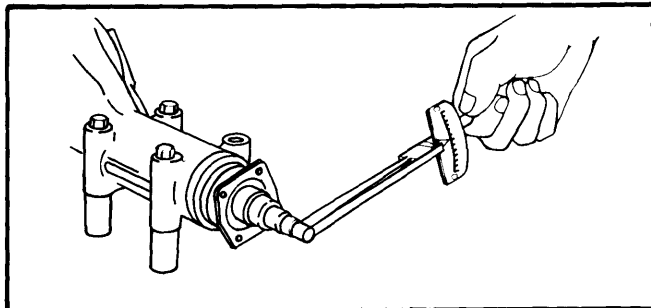

Fig. 8 Checking Drive Pinion Bearing Preload

**Drive Pinion Gear Installed Height** – 1) Leave dummy drive pinion shaft installed (as described under Preload Adjustment) and install height gauge (ST31211000 – 610 Series; KV38100120 – 280Z) in bearing bores in carrier. Measure clearance between end of pinion gear head and height gauge using a feeler gauge. Thickness of drive pinion height adjusting washer can be determined by using the following formula:

$$T = W + N - (H - D' - S) \times .01 - .2$$

**NOTE** – Formula values are given in Millimeters.

- T = Thickness of adjusting washer needed.
- W = Thickness of washer temporarily installed.
- N = Clearance between gauge and dummy shaft.
- H = Figure marked on drive pinion head.
- D' = Figure marked on dummy shaft.
- S = Figure marked on height gauge.

**NOTE** – If values signifying H, D, and S are not given, regard them as zero.

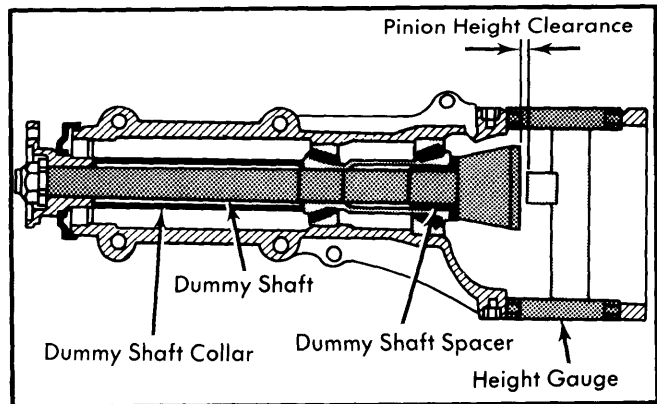

Fig. 9 Measuring Drive Pinion Gear Installed Height

2) After determining correct thickness of required pinion height adjusting washer, remove dummy shaft and height gauge. Fit correct pinion height adjusting washer on drive pinion gear and press fit rear bearing inner race. Lubricate pinion bearings then install drive pinion gear, pinion bearing spacer and washer, pilot bearing race, pilot bearing spacer, pilot bearing and oil seal. Install pinion flange and tighten pinion nut to specified torque.

**Side Bearing Preload** – 1) Required thickness of left and right side retainer shims can be obtained by the following formulas:

$$T_1 = (A + C + G_1 - D) \times .01 + .76 - E$$

$$T_2 = (B + D + G_2) \times .01 + .76 - F$$

**NOTE** – Formula values are given in Millimeters.

- T<sub>1</sub> = Required thickness of left side retainer shim.
- T<sub>2</sub> = Required thickness of right side retainer shim.
- A & B = Figure marked on gear carrier.
- C & D = Figure marked on differential case.
- E & F = Difference in width of left or right bearing.
- G<sub>1</sub> & G<sub>2</sub> = Figure marked on left or right retainers.

**NOTE** – If values signifying A, B, C, D, G<sub>1</sub>, and G<sub>2</sub> are not given, regard them as zero.

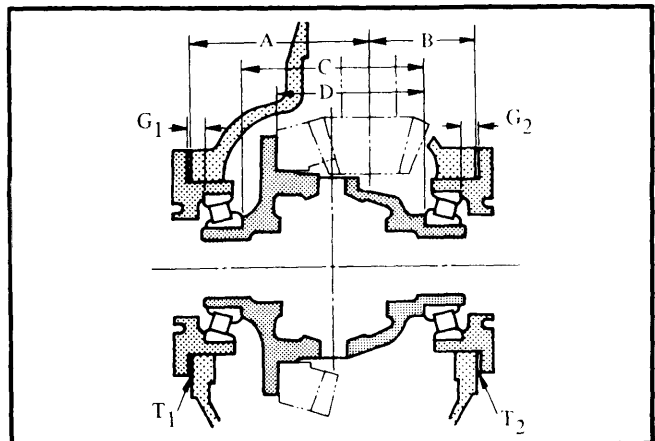

Fig. 10 Side Bearing Preload Formula Values

# Drive Axles

## DATSUN INTEGRAL HOUSING (I.R.S.) (Cont.)

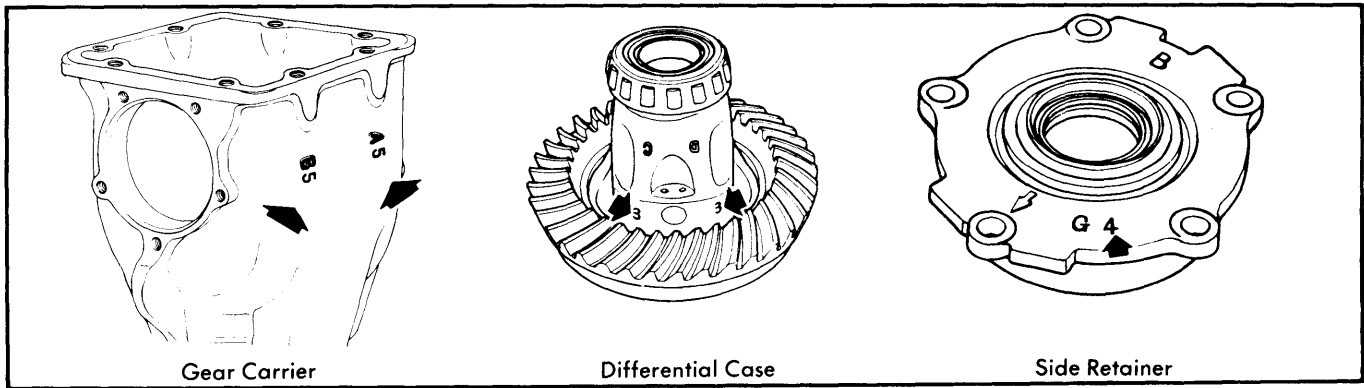

Fig. 11 Side Bearing Preload Identification Marks (610 Model Shown)

2) On 610 models, install differential case assembly in gear carrier in reverse order of disassembly. Fit correct shims and "O" ring seal in both side retainers in carrier. Arrow should point as shown in Fig. 12.

3) On 280Z models, install differential case assembly, with side bearing outer races, into gear carrier. Then insert side bearing washers and drive in spacer between right side washer and housing. Align mark on bearing cap with that on carrier and install bolts. Tighten to specification.

**NOTE** — Use care in installing spacer to avoid tilting side bearing outer race.

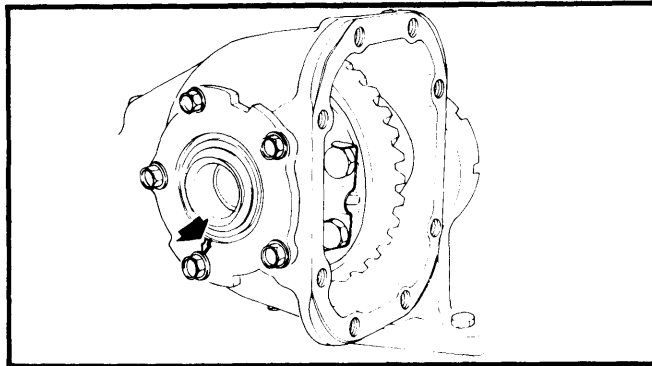

Fig. 12 Aligning Side Retainer During Installation (610 Model Shown)

4) Using dial indicator, measure ring gear-to-drive pinion backlash and adjust if necessary. Check side bearing preload, and adjust if necessary by adding or removing side retainer shims. **NOTE** — If side bearing preload is readjusted, ring

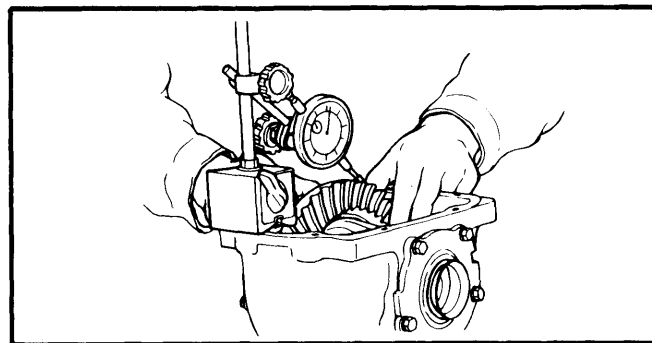

Fig. 13 Measuring Ring Gear Backlash

gear-to-drive pinion backlash must be checked and adjusted if necessary.

**Final Inspection & Assembly** — After all adjustments are to specifications, make tooth contact pattern test and make any necessary corrections. See *Gear Tooth Contact Pattern at beginning of this section*. Install rear cover and tighten nuts to specifications. Refill axle assembly to correct level with gear oil.

### AXLE ASSEMBLY SPECIFICATIONS

Application	Measurement
Pinion Bearing Preload w/o Oil Seal	INCH Lbs. (cmkg)
280Z .....	8.7-11.3 (10-13)
610 .....	6.1-8.7 (7-10)
Pinion Bearing Preload with Oil Seal	INCH Lbs (cmkg)
280Z .....	9.5-15.0 (11-17)
Ring-to-Pinion Gear Backlash	In. (mm)
280Z .....	.0051-.0071 (.13-.18)
610 .....	.0047-.0071 (.12-.18)
Side Gear Backlash	In. (mm)
280Z & 610 .....	.004-.008 (.1-.2)

### TIGHTENING SPECIFICATIONS

Application	Ft. Lbs. (mkg)
Rear Wheel Bearing Nut	
280Z & 610 .....	181-239 (25-33)
Driveshaft Flange Bolt	
280Z & 610 .....	36-43 (5-6)
Pinion Flange-to-Propeller Shaft Flange	
280Z .....	29-33 (4.0-4.5)
610 .....	17-24 (2.4-3.3)
Rear Cover Bolts	
280Z .....	12-17 (1.6-2.4)
610 .....	14-19 (1.9-2.6)
Rear Cover-to-Mounting Member	
280Z .....	54-69 (7.5-9.5)
610 .....	43-58 (6-8)
Ring Gear Bolts	
280Z .....	43-51 (6-7)
610 .....	51-58 (7-8)
Side Bearing Cap Bolts (280Z Only) .....	65-72 (9-10)