

SAAB

99

DESCRIPTION

Clutch is dry, single plate, diaphragm spring type, attached to flywheel on end of crankshaft. A clutch shaft is splined into clutch and a primary gear assembly, to transmit power from engine to transmission, located below engine. Clutch actuation is hydraulic, consisting of a firewall mounted master cylinder and a clutch housing mounted slave cylinder.

REMOVAL & INSTALLATION

CLUTCH ASSEMBLY

Removal — 1) Remove hood and disconnect battery ground cable. Drain radiator, and disconnect wires from fan motor and switch on radiator. Disconnect all water hoses from radiator. Remove air cleaner cold air hose, front panel, and radiator.

2) Disconnect wiring from coil, temperature sending unit, and oil pressure switch. Remove clutch cover and spring at slave cylinder. Back off clutch adjusting screw and lower clutch release lever. Remove lock ring and sealing cap over clutch shaft.

3) Remove clutch shaft centering screw, washer, and "O" ring. Pull clutch shaft using suitable tools (8390270 & 8390015). Remove all clutch attaching bolts except top two.

4) Remove bolts attaching release bearing guide sleeve. Using suitable tool (8392078), clamp clutch and release bearing together. Pressure plate, clutch disc, and release bearing with guide sleeve can then be removed.

Installation — 1) Place clutch disc in flywheel. Press together clutch and release bearing using a suitable tool (8392078). If necessary, use guide spindle (8790412) for centering release bearing. Press guide sleeve into release bearing and place clutch assembly into position.

2) Align clutch disc using clutch shaft. Slide clutch onto locating pins and tighten top bolts lightly. Tighten guide sleeve attaching screws.

3) Remove clutch tool and tighten clutch attaching bolts. Install clutch shaft center screw, washer and "O" ring. Install sealing cap and lock ring over clutch shaft.

4) Align clutch lever and install spring at slave cylinder. Adjust clutch release lever clearance.

CLUTCH MASTER CYLINDER

Removal & Installation — Disconnect hydraulic line from cylinder, then pump fluid into a container. Disconnect push rod from clutch pedal by removing cotter pin and clevis pin. Remove cylinder attaching bolts and remove cylinder. To install, reverse removal procedure and bleed hydraulic system.

CLUTCH SLAVE CYLINDER

Removal & Installation — Loosen clutch adjusting lock nut and back off adjusting screw. Disconnect spring from release lever and push lever back to clear slave cylinder push rod. Remove attaching bolts and slave cylinder. To install, reverse removal procedure and bleed hydraulic system.

PILOT BUSHING

Removal — Fill bushing cavity with grease, then insert a centering tool into bushing. Tap tool lightly with a mallet to force out bushing. If necessary, add more grease as bushing is driven out.

Installation — Clean all grease from crankshaft, taking care not to get any on flywheel friction surface. Install new bushing using a centering tool.

OVERHAUL

CLUTCH MASTER CYLINDER

Disassembly — Pull back sealing bellows and remove retaining ring. Remove push rod and washer. Remove piston, convex washer, piston seal, and spring. Inspect cylinder bore for wear or damage. Replace complete assembly if cylinder is worn or damaged. Replace seal if worn or swollen.

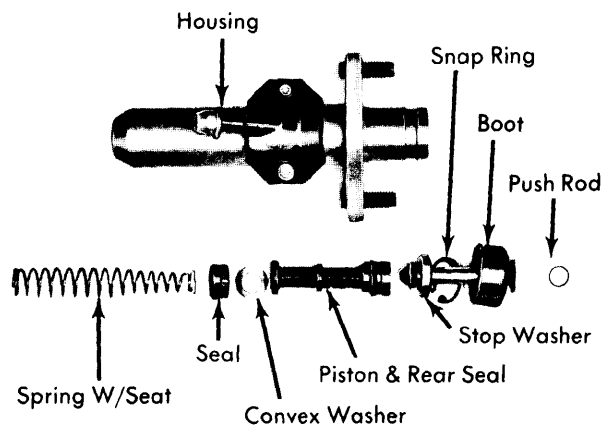

Fig. 1 Exploded View of Clutch Master Cylinder

Reassembly — Install return spring and spring retainer. Lubricate piston and seals with Girling Rubber Grease No. 3. Install seals, convex washer and piston. Install push rod followed by washer and retaining ring. Install sealing bellows.

NOTE — When installing convex washer, convex side must face piston. See Illustration.

Clutches

SAAB (Cont.)

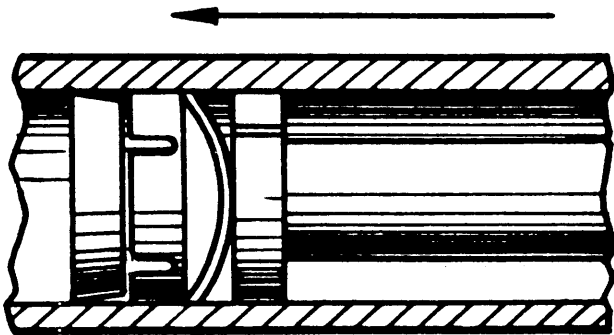

Fig. 2 Installed View of Master Cylinder Convex Washer

CLUTCH SLAVE CYLINDER

Disassembly & Reassembly – Remove rubber sealing cap and retaining ring. Remove piston and seal. Inspect cylinder bore, piston and seal for wear or damage, replace as necessary. To reassemble, reverse disassembly procedure. Lubricate piston and seal with Girling Rubber Grease No. 3.

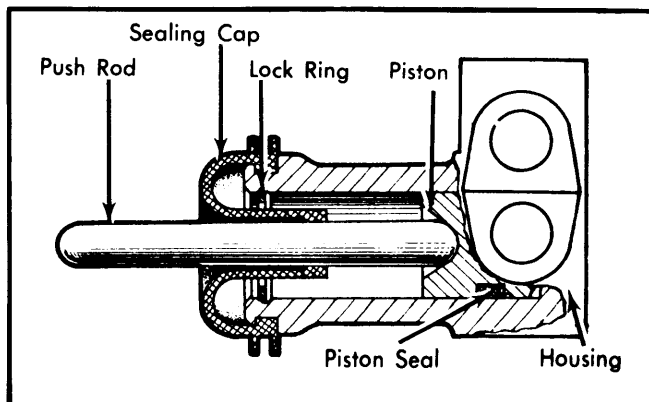

Fig. 3 Sectional View of Clutch Slave Cylinder

ADJUSTMENT

CLUTCH ADJUSTMENT

Clutch play is regulated by an adjusting screw threaded into transmission case. Check free play at outer end of release

lever; free play should be .10-.14". If adjustment is required, loosen lock nut and turn adjusting screw until proper free play is obtained. Tighten lock nut.

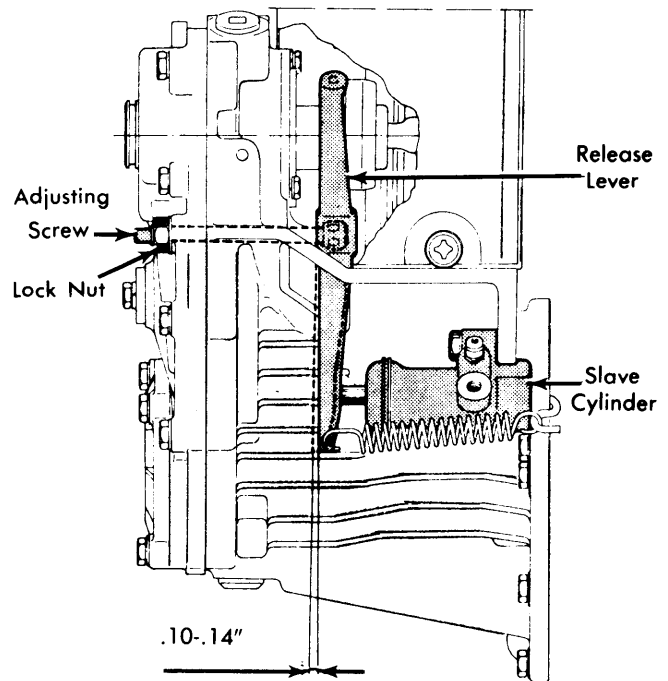

Fig. 4 View Showing Clutch Adjustment Points

HYDRAULIC SYSTEM BLEEDING

1) Connect a 1/4" hose to slave cylinder bleeder screw, and place opposite end in a container partially filled with hydraulic fluid. Fill master cylinder reservoir with hydraulic fluid. Open bleeder screw on slave cylinder 1/2 turn.

2) Place a coolant system tester over filler opening of master cylinder. Pump tester until all air has been removed from system. Close slave cylinder bleeder screw and check to see that all air has been expelled by depressing clutch pedal.