

DATSUN F10

Datsun F10

DESCRIPTION

Clutch is a single, dry disc, diaphragm spring type. Main components consist of: clutch cover, pressure plate, and diaphragm spring. Clutch plates are riveted together. A release bearing and fork control clutch engagement and disengagement. Clutch is hydraulic type with a firewall mounted master cylinder and clutch housing mounted slave cylinder.

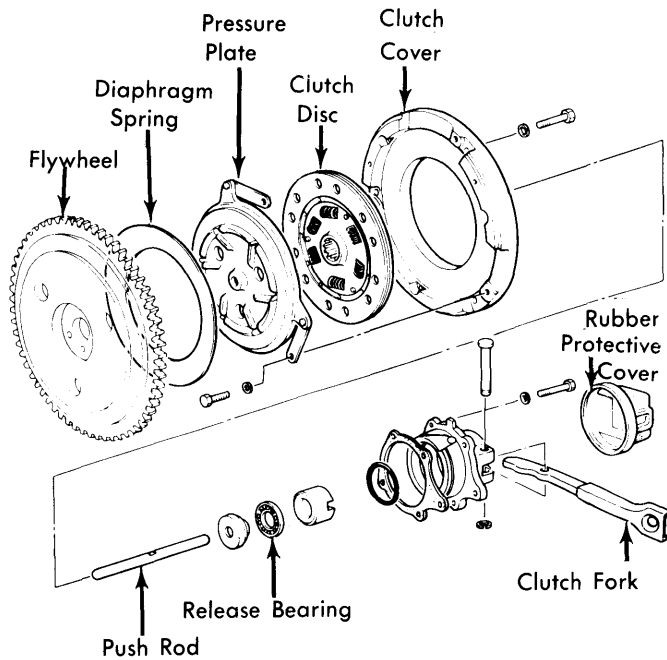

Fig. 1 Exploded View of Clutch Components

REMOVAL & INSTALLATION

CLUTCH ASSEMBLY

NOTE — Clutch assembly can be serviced, removed, or overhauled while transmission and engine remain in vehicle. Also, transmission cannot be removed without removing engine.

Removal — 1) Disconnect the following: Battery ground cable, fresh air duct, electrical connectors on clutch housing and carbon canister hoses. Remove upper portion of clutch housing inspection cover, then take out six bolts mounting clutch cover.

NOTE — To gain access to mounting bolts, raise right front wheel and rotate by hand until bolts are visible.

2) Turn wheels to left stop, then remove right side inspection cover and disconnect clutch release fork. Remove six bolts on bearing housing. Pull out primary drive gear assembly. (See Fig. 2). Lift out clutch cover and disc through inspection opening. Remove strap securing pressure plate to clutch cover. Keep strap in relative position since it is part of dynamic balance.

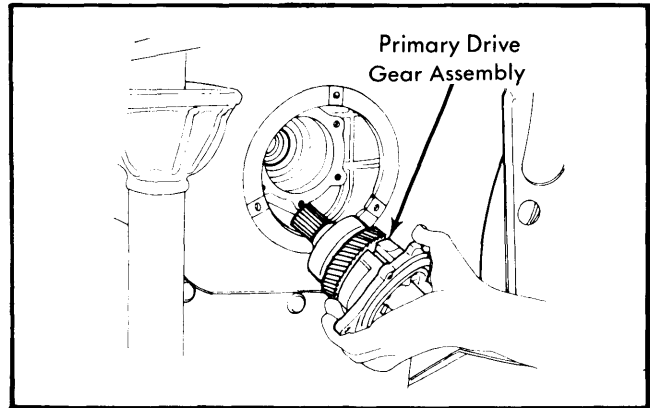

Fig. 2 Removing Primary Drive Gear Assembly

Installation — To install, reverse removal procedure and note the following: Make sure all alignment marks are positioned before tightening.

RELEASE BEARING

Removal — Separate release lever by removing pivot pin and removing bearing housing. Remove "O" ring and bearing. Hold bearing and rotate outer race, replace if operation is rough or noisy.

Installation — To install, reverse removal procedure and apply multi-purpose grease to sliding parts of release lever.

CLUTCH MASTER CYLINDER

Removal — Remove lock ring from clevis pin and pull out clevis pin. Disconnect and plug clutch line from master cylinder. Remove nuts mounting master cylinder to instrument panel.

Installation — To install, reverse removal procedure and note the following: Adjust pedal play and bleed air from hydraulic system.

SLAVE CYLINDER

Removal — Disconnect clutch hose from slave cylinder. Remove two bolts mounting slave cylinder to clutch housing.

Installation — To install, reverse removal procedure and note the following: Bleed air from hydraulic system.

OVERHAUL

MASTER CYLINDER

Disassembly — Remove dust cover and pull stopper ring from cylinder body. Remove push rod, then take out entire piston assembly.

Inspection — Wash all internal parts in clean brake fluid. Check cylinder bore and piston for burrs or score marks. Check bore for wear. If clearance between bore and piston is more than .006" (.15 mm), piston must be replaced. Check all passages to make sure they are clear.

DATSUN F10 (Cont.)

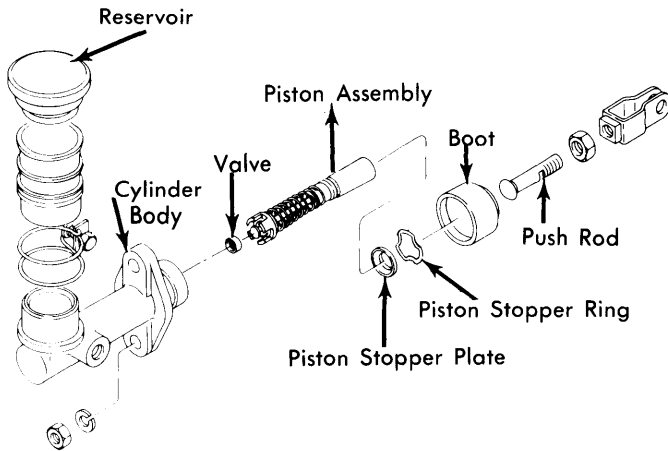

Fig. 3 Exploded View of Master Cylinder

Reassembly — To reassemble, reverse disassembly procedure and note the following: Make sure piston cup is correctly positioned. Apply a light coat of brake fluid to cylinder and piston.

SALVE CYLINDER

Disassembly — Remove dust boot. Separate remaining components as shown in Fig. 4.

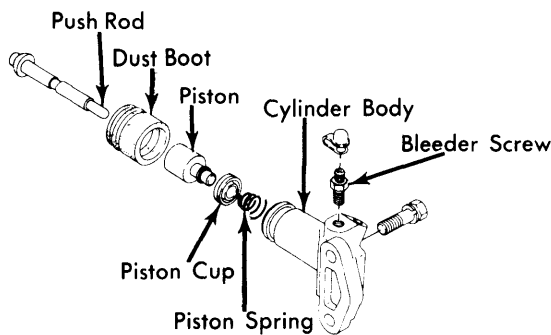

Fig. 4 Exploded View of Clutch Slave Cylinder

Inspection — Visually inspect all components and replace those which indicate signs of damage or wear. Clean all components in brake fluid. Check cylinder piston and bore for score marks and rust. Inspect cylinder bore and piston for wear. If clearance is more than .006" (.15 mm), replace piston. Make sure bleed hole is dirt free.

Reassembly — To reassemble, reverse disassembly procedure and note the following: Apply a light coat of brake fluid to cylinder and piston before reassembly.

NOTE — When pressure plate and clutch disc are replaced, or if any components of release mechanism is replaced, a new push rod may have to be installed.

ADJUSTMENTS

CLUTCH PEDAL HEIGHT & FREE PLAY

Adjust clutch pedal height by turning master cylinder push rod. Correct height is 6.65-6.9" (169-175 mm). Tighten lock nut. Adjust stopper nut so pedal free play is .236-.551" (6-14 mm). Tighten lock nut. Fig. 5.

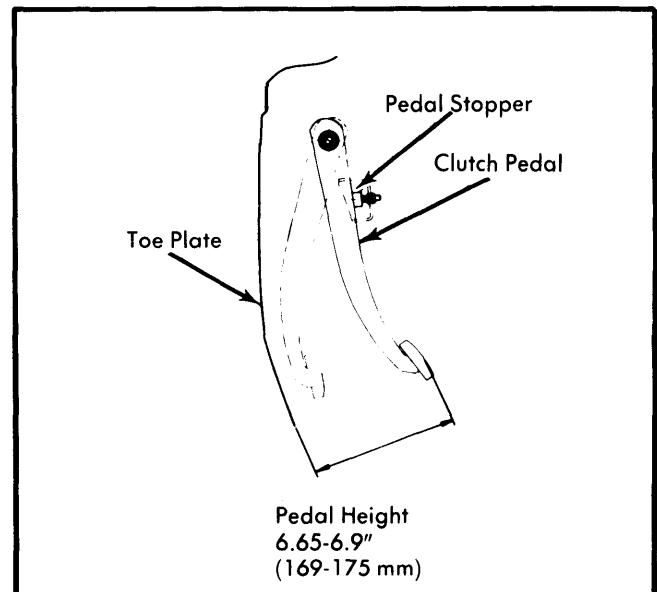

Fig. 5 Pedal Height and Free Play Adjustment

HYDRAULIC SYSTEM BLEEDING

Fit bleeder hose to bleeder valve. Place opposite end into a clear container partially filled with brake fluid. Pump clutch pedal two or three times and hold to floor. Break bleeder valve loose and allow air to vent. Close bleeder screw and allow pedal to return. Repeat procedure several times.

TORQUE SPECIFICATIONS

Application	Ft. Lbs. (mkg)
Clutch Cover Assembly.....	5.1-7.2 (.7-1.0)
Pressure Plate Strap.....	5.1-5.8 (.7-.8)
Bleeder Screw	5.1-6.5 (.7-.9)
Push Rod Lock Nut	5.8-8.0 (.8-1.1)
Master Cylinder-to-Instrument Panel.....	5.8-8.0 (.8-1.1)
Slave Cylinder Bolts.....	12-15 (1.6-2.1)