

COURIER

Courier

DESCRIPTION

Clutch is of single dry disc type. Clutch assembly consists of clutch disc, clutch cover and pressure plate assembly, and clutch release mechanism. Clutch housing also acts as the transmission input shaft bearing retainer, and contains the input shaft bearing oil seal and a selective fit thrust washer for controlling input shaft end play. Clutch release mechanism is hydraulic, consisting of a firewall mounted master cylinder and a slave cylinder mounted on flywheel housing. To control clutch engagement, a one-way valve mounted on master cylinder controls flow of return fluid when pressure on clutch pedal is released.

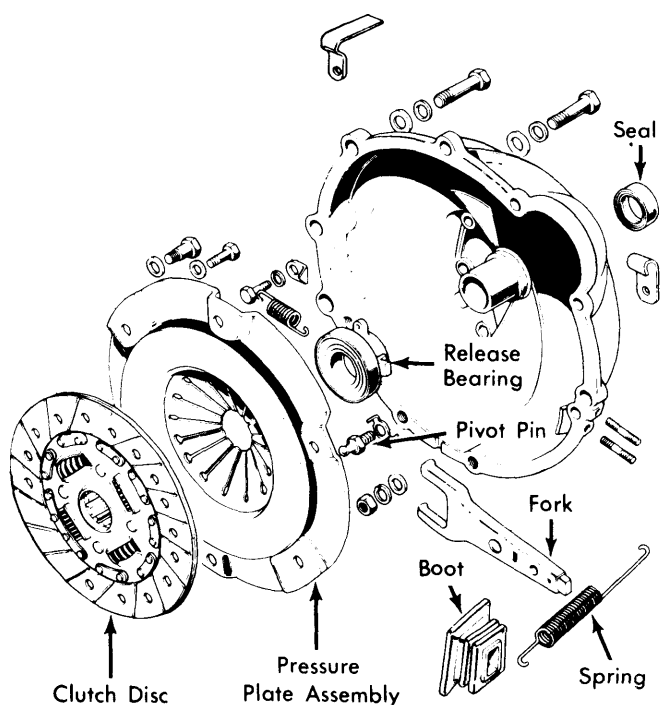

Fig. 1 Exploded View of Clutch Assembly

REMOVAL & INSTALLATION

CLUTCH ASSEMBLY

- 1) Place gear shift lever in neutral and remove shift lever, tower and boots as an assembly. Raise vehicle, disconnect drive shaft at rear axle and at center bearing support and remove from transmission.
- 2) Disconnect exhaust pipe brackets from transmission case and clutch housing. Remove exhaust pipe and resonator assembly. Disconnect clutch release lever return spring. Remove clutch slave cylinder and secure to one side.
- 3) Remove speedometer cable from extension housing and disconnect wiring from starter and transmission. Using a suitable jack, support engine and remove starter. Support transmission and remove transmission-to-engine rear plate attaching bolts.

- 4) Remove crossmember attaching bolts at transmission and frame side rails, and remove crossmember. Lower jack supporting engine and remove transmission by sliding rearward and downward. Mark location of two pilot bolt holes on flywheel and pressure plate and remove clutch attaching bolts and clutch assembly.

- 5) To install, reverse removal procedure noting the following: Use a suitable centering tool to align clutch disc to flywheel. Install pressure plate, four standard, and two pilot bolts finger tight. To avoid distorting pressure plate, tighten bolts a few turns at a time until tight, using a criss-cross pattern. Bleed hydraulic system and adjust clutch pedal free play.

RELEASE LEVER & BEARING

- 1) With transmission removed, disconnect release collar spring and slide out release lever, boot and release bearing. Inspect all parts for wear or damage.
- 2) To install, apply lubricant to input shaft bearing retainer portion of clutch housing and pivot bolt. Drive release lever onto pivot. Apply lubricant to bearing contact surface of lever and install release bearing and hook release collar spring. Apply lubricant to face of release bearing. Check to see that lever and bearing operate freely.

CLUTCH MASTER CYLINDER

- 1) Disconnect fluid outlet line at master cylinder one-way valve. Remove nuts and bolts attaching master cylinder to firewall and pull cylinder out and away.
- 2) To install, start pedal push rod into master cylinder, then position cylinder against firewall. Install and tighten attaching bolts and connect fluid outlet line. Bleed hydraulic system and check pedal free play.

CLUTCH SLAVE CYLINDER

- 1) Disconnect fluid inlet hose at slave cylinder. Unhook release lever return spring. Remove nuts attaching slave cylinder to clutch housing and remove cylinder.
- 2) To install, locate cylinder to studs on housing, install and tighten nuts. Connect fluid inlet hose, fill master cylinder, and bleed hydraulic system. Check and adjust release lever free travel, and hook lever return spring.

OVERHAUL

CLUTCH MASTER CYLINDER

- 1) Clean outside of cylinder, drain fluid, and remove dust boot. Using a screwdriver, remove piston stop ring and washer. Remove piston, piston cup and return spring from cylinder, then carefully remove and disassemble one-way valve.
- 2) Wash all parts in clean alcohol or brake fluid. Check all rubber components and replace if damaged, worn, softened or swollen. Check cylinder bore for wear or damage, and check clearance between cylinder bore and piston. Replace cylinder or piston if clearance is more than .004" (.102 mm)

Clutches

COURIER (Cont.)

3) To assemble, dip all parts in clean brake fluid and reverse disassembly procedure. When assembled, fill reservoir with fluid and operate piston with a screwdriver until fluid is ejected at outlet fitting.

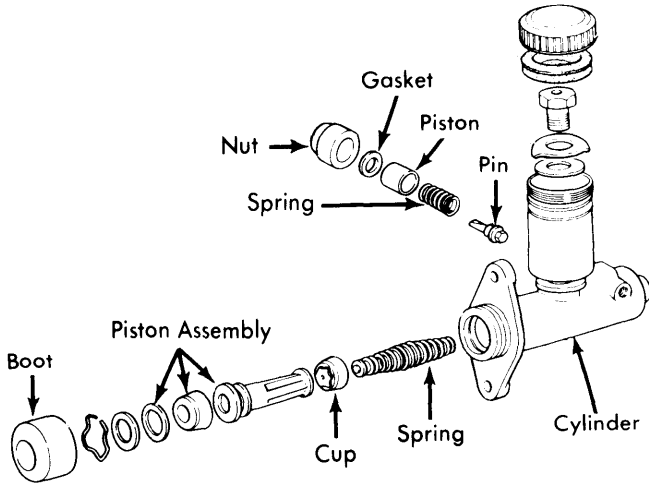

Fig. 2 Exploded View of Clutch Master Cylinder Assembly

SLAVE CYLINDER

1) Clean outside of cylinder thoroughly, then remove dust boot and clutch release rod. Remove piston and disassemble bleeder valve. Inspect all parts for wear or damage, replace as necessary.

2) To assemble, dip piston and cups into clean brake fluid, assemble cups to piston, install piston. Install release rod and boot, install steel ball and bleeder into bleeder orifice, and install bleeder cap.

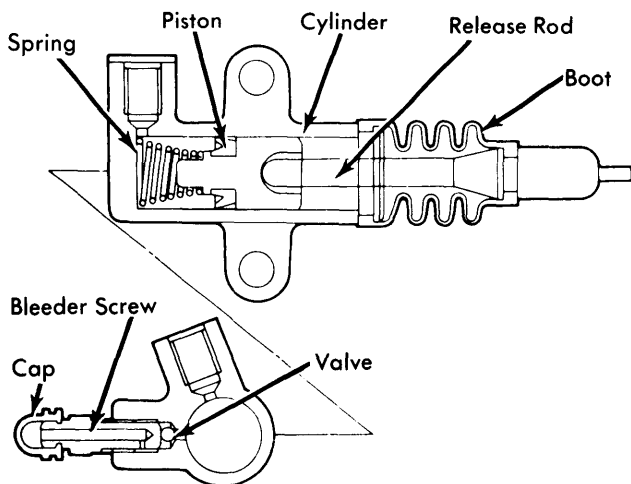

Fig. 3 Sectional View of Clutch Slave Cylinder Assembly

ADJUSTMENT

CLUTCH PEDAL

Pedal free play is adjusted by loosening lock nut on push rod and rotating rod until .025-.121" (.64-3.07 mm) free travel is obtained at pedal pad. See Fig. 4. Tighten lock nut when adjustment is completed.

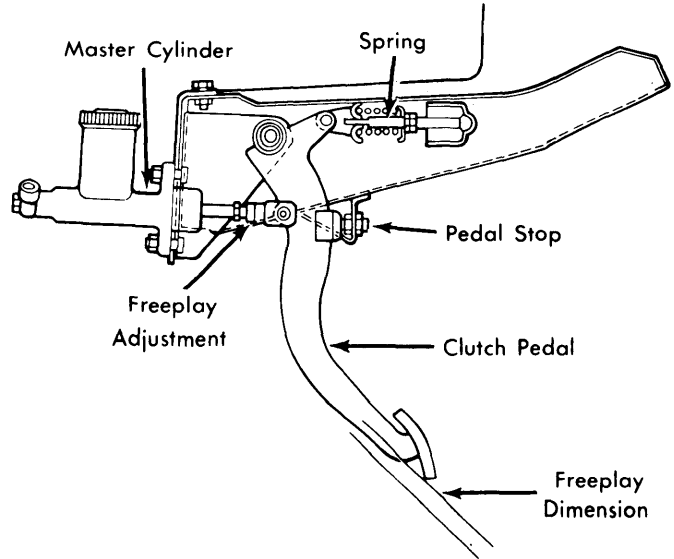

Fig. 4 Clutch Pedal Adjustment Procedure

CLUTCH RELEASE LEVER

Raise vehicle, then disconnect return spring at release lever. Loosen lock nut and rotate adjusting nut until clearance of .125-.141" (3.2-3.6 mm) is obtained between bullet-nosed end of adjusting nut and release lever. Tighten lock nut securely.

HYDRAULIC SYSTEM BLEEDING

Remove rubber cap from bleeder valve and attach a bleeder tube and fixture to bleeder screw. Place other end of tube in a glass jar of brake fluid and open bleeder screw. Depress clutch pedal and allow to return slowly. Continue pumping action until air bubbles cease to appear in glass jar, then close bleeder screw. Install rubber cap on bleeder screw and fill master cylinder. **NOTE** - During bleeding, master cylinder must be kept $\frac{3}{4}$ full of brake fluid.

TIGHTENING SPECIFICATIONS

Application	Ft. Lbs. (mkg)
Clutch Housing-to-Engine	24-42 (3.3-5.8)
Pressure Plate-to-Flywheel	13-20 (1.8-2.8)
Release Lever Return Spring Bracket	5-8 (.7-1.1)
Slave Cylinder-to-Clutch Housing	12-17 (1.7-2.4)
Master Cylinder-to-Firewall	12-17 (1.7-2.4)
Pivot Pin	23-34 (3.2-4.7)