

## BMW 2002

2002

### DESCRIPTION

Clutch is dry, single plate, diaphragm spring type design. Clutch release system is self-adjusting and hydraulically actuated.

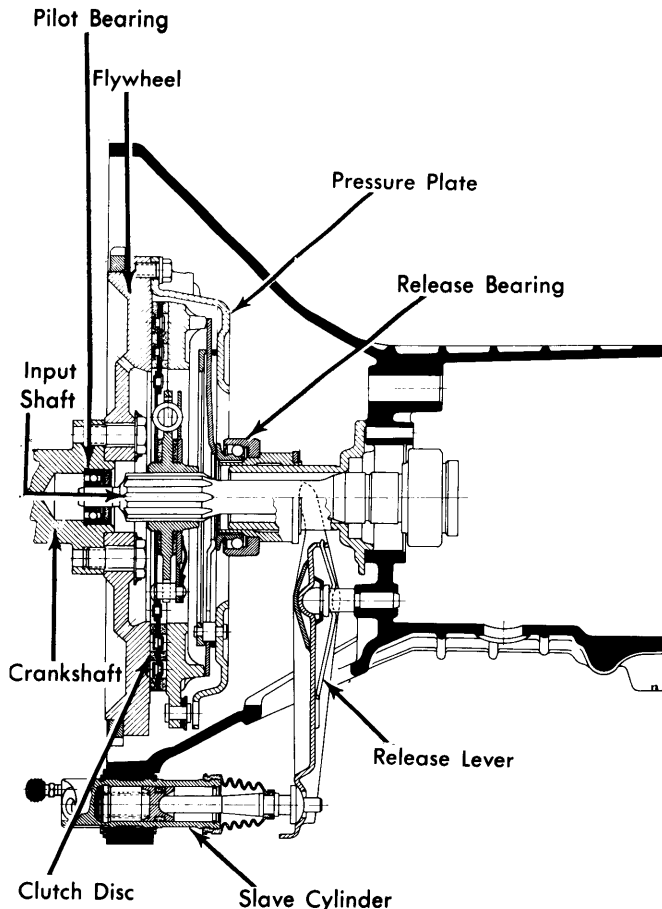

Fig. 1 Sectional View of Clutch Assembly

### REMOVAL & INSTALLATION

#### CLUTCH ASSEMBLY

- 1) From engine compartment, remove all accessible transmission to engine attaching bolts. From inside driver compartment, pull up on rubber boot and foam rubber ring to expose snap ring, then remove snap ring and shifter assembly.
- 2) With vehicle on hoist, remove exhaust bracket from rear of transmission, then remove exhaust pipe from exhaust manifold. Disconnect propeller shaft from transmission flange, then remove center support bearing mount. Push shaft down, pull back to remove.
- 3) Remove pivot pin from gear shift and rod union, then push gear shift lever up. From slave cylinder, remove boot retaining ring and boot, then remove cylinder retaining ring and slide slave cylinder forward to remove.
- 4) Remove clutch inspection cover from transmission, then support engine by placing a wooden block between oil pan and crossmember. Disconnect speedometer cable and electrical leads from transmission, then remove crossmember from rear of transmission.

5) Turn steering completely to right, remove remaining transmission to engine attaching bolts, then move transmission to rear to remove. Loosen clutch retaining bolts alternately and evenly, then remove clutch assembly.

6) To install, reverse removal procedure and note the following: Use a suitable centering tool (BMW 603) to align clutch disc on flywheel. Tighten pressure plate to flywheel bolts alternately and evenly. When installing propeller shaft, preload center support bearing by pushing forward .08" and tightening bolts in this position.

#### CLUTCH MASTER CYLINDER

- 1) Siphon brake fluid out of master cylinder reservoir until fluid level is below "MIN" line. Remove fluid supply line from master cylinder, then disconnect fluid line to slave cylinder.
- 2) From inside driver compartment, pull carpet from around pedal assembly, then disconnect master cylinder push rod from clutch pedal. Remove cylinder attaching bolts and remove cylinder.
- 3) To install, reverse removal procedure and note the following: Make sure an air tight seal is obtained when fitting fluid supply line to master cylinder. Coat clutch pedal bolts and bushings with Molykote Longterm 2 lubricant. Bleed hydraulic system.

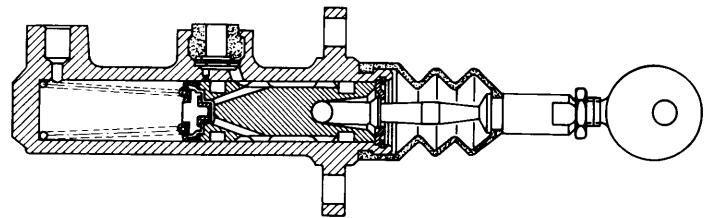

Fig. 2 Sectional View of Clutch Master Cylinder

#### CLUTCH SLAVE CYLINDER

- 1) Siphon brake fluid out of master cylinder reservoir until fluid level is below "MIN" line. Remove slave cylinder boot retaining ring, then remove circlip retaining slave cylinder in transmission housing.
- 2) Remove fluid pressure line from cylinder, then remove by pulling cylinder out toward front of vehicle. To install, reverse removal procedure and note the following: Tang on slave cylinder must engage slot in clutch inspection cover for correct positioning. Bleed hydraulic system.

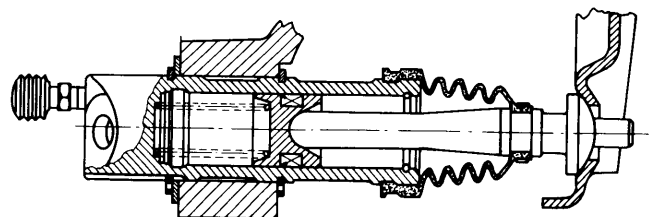

Fig. 3 Sectional View of Clutch Slave Cylinder

#### CLUTCH RELEASE BEARING & FORK

- 1) With transmission removed, and with slave cylinder removed from transmission, lift spring on release lever above collar of knuckle bolt on transmission housing. Remove lever from inside clutch housing portion of transmission case.

# Clutches

## BMW 2002 (Cont.)

2) To install, reverse removal procedure and note the following: Coat support springs, angular seal, knuckle bolt and release bearing collar with Molykote Longterm 2 lubricant. **NOTE** — Angular seal of lever must be located between knuckle bolt and release lever.

### PILOT BEARING

1) With clutch assembly removed, rotate bearing in end of crankshaft and check for roughness or noise. If defective, remove bearing using a suitable puller.

2) To install, lubricate bearing with high melting point grease, then install into end of crankshaft, followed by cover plate (symbol facing out), lubricated felt ring and cap. Drive in cap until a tight fit is obtained.

### ADJUSTMENT

**NOTE** — Due to automatic wear adjustment feature, no adjustment, with the exception of bleeding hydraulic system, is necessary.

### BLEEDING HYDRAULIC SYSTEM

Attach a suitable hydraulic system bleeder to master cylinder. Open bleeder screw and allow system to expel air. Bleeding operation is complete when air bubbles are no longer seen in fluid container.

### TIGHTENING SPECIFICATIONS

Application	Ft. Lbs. (mkg)
Clutch-to-Flywheel .....	11-14 (1.5-1.9)
Fluid Pressure Line-to-Cylinders .....	12 (1.6)
Master Cylinder Attaching Bolts.....	14-17 (1.9-2.4)
Clutch Pedal Through Bolt .....	23-25 (3.1-3.4)
Transmission-to-Engine	
M8 Bolts.....	18 (2.5)
M10 Bolts.....	34 (4.7)