

Triumph Engines

SPITFIRE 4 CYLINDER

GENERAL SPECIFICATIONS										
Year	Displ.		Carburetor	HP at RPM	Torque (Ft. Lbs. at RPM)	Compr. Ratio	Bore		Stroke	
	cu. ins.	cc					in.	mm	in.	mm
1976	91	1493	1x1-Bbl.	9.0-1⓪	2.90	73.7	3.44	87.5

⓪ — Federal; 7.5-1 California.

ENGINE IDENTIFICATION

Engine number is stamped on a machined flange on left side of cylinder block. Number can be broke down as follows:

FM1234UCE

1st & 2nd Digits — Model range.

3rd through 6th Digits — Sequence build number.

7th Digit — USA market.

8th Digit — Calif. market (Catalytic Converter).

9th Digit — Engine unit.

ENGINE

Removal — 1) Disconnect battery. Drain coolant and engine oil. Remove hood. Remove air cleaner and disconnect emission control lines. From exhaust manifold, separate converter or pipe.

2) Disconnect all necessary water hoses, carburetor throttle linkage, and engine electrical leads. Disconnect and plug fuel lines.

3) Raise vehicle and place on safety stands. Separate exhaust pipe from bracket at transmission, then pull pipe downward past chassis. Take off restraint cable. Remove lower bell housing nuts and bolts. Place jack or stand under bell housing.

4) Lower vehicle to ground. Attach hoist to engine. Remove remaining bell housing bolts, then take out starter. Remove motor mount bolts. Remove engine with hoist.

Installation — installation is largely the reverse of removal procedure.

INTAKE MANIFOLD

1) Remove air cleaner and disconnect fuel line. Disconnect hose to rocker cover. Unhook throttle return spring. Disconnect

and remove throttle cable. Disconnect choke cable, ignition vacuum line and water hoses.

2) Unscrew manifold bolts connecting intake to exhaust manifold. Remove manifold-to-engine bolts and lift out manifold assembly.

CYLINDER HEAD

Removal — 1) Disconnect battery. Drain coolant. Disconnect emission control hoses and vacuum lines; mark for reinstallation. Loosen alternator belt. Disconnect heater hoses. Disconnect fuel evaporation hoses. Separate throttle linkage from carburetor. Remove valve cover. Disconnect heater return line.

2) Remove heat shield from between carburetor and air cleaner. Disconnect exhaust at manifold flange. Remove water pump. Remove rocker arm assembly. Take out push rods. Disconnect fuel line and remove cylinder head.

NOTE — It may be necessary to remove intake and exhaust manifolds.

Installation — Note following during installation. Make sure "TOP" tag on rear of gasket faces up.

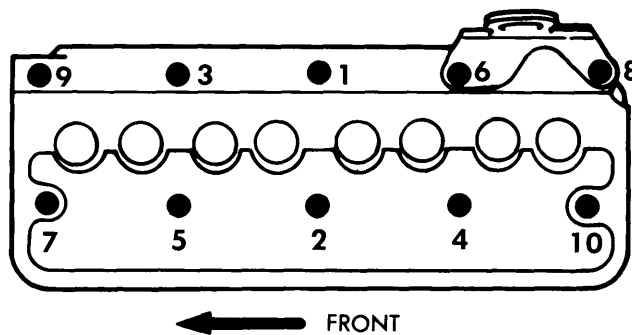

Fig. 1 Cylinder Head Tightening Sequence

VALVES In. (mm)							
Engine & Valve	Head Diam.	Face Angle	Seat Angle	Seat Width	Stem Diameter	Stem Clearance	Valve Lift
1493 cc Intake	1.375-1.385 (34.97-35.01)	45°	45°	.248-.250⓪ (6.29-6.35)	.3107-3113 (7.892-7.907)	.0008-.0023 (.020-.060)	...
Exhaust	1.168-1.172 (29.66-29.76)	45°	45°	.248-.250⓪ (6.29-6.35)	.3100.3105 (7.874-7.887)	.0015-.0030 (.038-.076)	...

⓪ — With catalytic converter .258-.260" (31.95-31.00 mm).

SPITFIRE 4 CYLINDER (Cont.)

VALVE ARRANGEMENT

E-I-I-E-E-I-I-E (front to rear).

VALVE GUIDE SERVICING

1) Inspect valve guide wear by inserting a new valve, lifting it slightly off its seat, and rocking sideways. Movement of valve head across seat should not exceed .020" (.51 mm).

2) If replacement is required, use suitable tool (S.60A-6) to remove and replace valve guide. Guide protrusion above top face of cylinder head must lie between .749-.751" (19.02-19.08 mm).

VALVE SPRINGS			
Engine	Free Length In. (mm)	PRESSURE Lbs. @ In. (kg @ mm)	
		Valve Closed	Valve Open
1493 cc	1.52 (38.6)	...@1.342 ...@(34.1)	20 @ .875 (2.8 @ 22.2)

VALVE SPRINGS

Using suitable valve spring compressor, remove valve retainers. Withdraw collars and valves. Check valve springs for cracks, distortion and load length. When any one spring is defective, it is advisable to replace all springs.

NOTE — Valve springs can be removed with cylinder head installed in vehicle. Apply air pressure to spark plug hole of spring (valve) to be removed. Air pressure will prevent valve from dropping.

ROCKER ARM ASSEMBLY

Remove rocker arm cover. Progressively and evenly remove rocker arm pedestal nuts. Lift off rocker arm assembly. Pull cotter pin from front end of rocker shaft. Slide rockers, pedestals, springs and spacers from shaft, noting order for reassembly. Remove screw locating rear pedestal to shaft. Inspect and replace excessively worn parts. To install, reverse removal procedure making sure rear pedestal screw correctly engages rocker shaft.

VALVE TAPPETS

Check valve tappets for chips, score marks, ridges or excessive wear. Replace as necessary and ensure tappets are free to slide and rotate.

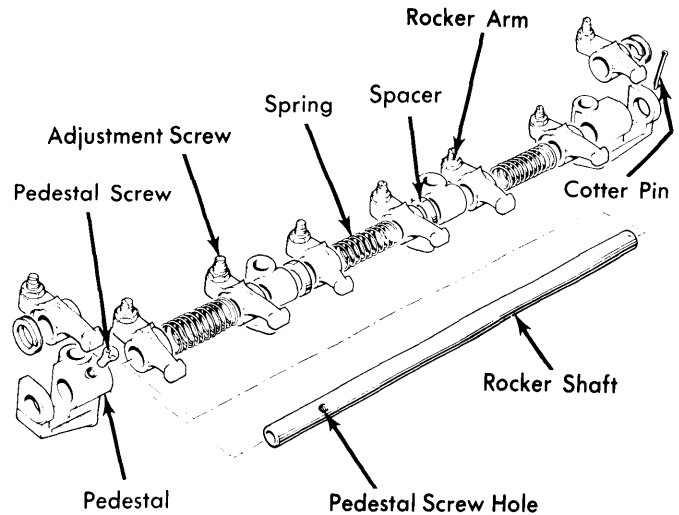

Fig. 2 Detailed View of Rocker Arm Assembly

VALVE CLEARANCE ADJUSTMENT

Disconnect battery, then remove rocker cover and spark plugs. Make necessary adjustment in sequence as indicated in chart below. Turning adjustment screw clockwise will decrease clearance, and turning screw counterclockwise will increase clearance. Proper clearance for intake and exhaust valves is .010" (.25 mm).

Valves Open ①

No. 8 & 6.....	No. 1 & 3
No. 4 & 7.....	No. 5 & 2
No. 1 & 3.....	No. 8 & 6
No. 5 & 2.....	No. 4 & 7

Valves to Adjust

① — Counting from front.

PISTONS, PINS, RINGS In. (mm)						
Engine	PISTONS	PINS		RINGS		
	Clearance	Piston Fit	Rod Fit	Rings	End Gap	Side Clearance
1493	.002-.003 (.05-.07)	Push Fit	Push Fit	No. 1 & 2 Oil	.012-.022 (.30-.55) ①	.002-.0025 (.051-.063) .0038-.0048 (.097-.122)

① — Ends butt.

SPITFIRE 4 CYLINDER (Cont.)

OIL PAN

Removal — Drain oil pan (Calif. models have a bolt with a banjo and two washers instead of the regular sump plug). Remove the 16 bolts mounting oil pan to engine. Drop out oil pan and remove gasket.

Installation — Clean mating surfaces. Lightly coat both sides of gasket with grease or sealer. Refit pan. Make sure longer bolts are fitted to rear of pan.

PISTON & ROD ASSEMBLY

- 1) Disconnect battery ground cable and drain engine oil. Remove oil pan and cylinder head as previously described.
- 2) Remove pickup strainer and bring No. 1 & No. 4 connecting rods to accessible position. Index bearing caps and connecting rods.

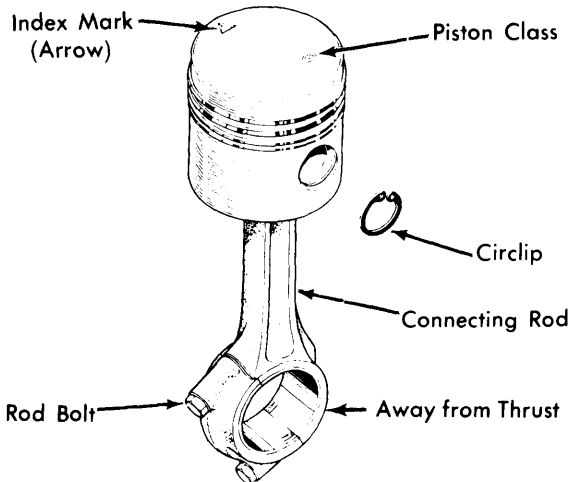

Fig. 3 Assembled View of Piston and Connecting Rod

3) Remove connecting rod bolts and withdraw bearing caps. Push pistons and connecting rods upward, withdrawing them out top of cylinder. Attach bearing cap to respective connecting rod.

4) To install, position No. 1 and No. 4 connecting rods at bottom dead center. Lube journals and connecting rod assemblies with engine oil. Insert connecting rod assembly into cylinder. Make sure arrow on piston head faces engine FRONT. Stagger piston rings away from thrust side of piston. Make sure connecting rod bearing is away from thrust side of cylinder bore.

5) Fit upper bearing and pull connecting rod over crankshaft. Install lower bearing cap and torque bolts to specifications.

PISTON PIN REPLACEMENT

1) Remove circlips from pistons and extract piston pin. Separate piston from connecting rod. Inspect connecting rod bushing for wear and replace if necessary.

2) Using suitable press, remove worn bushing and install replacement. Ensure oil hole in new bushing is aligned with hole in connecting rod. Ream bushing to fit piston pin. Piston pin diameter is .8123-.8125" (20.63-20.64 mm) and is a thumb push fit at 68°F (20°C).

FITTING PISTONS

1) Measure piston across skirt. Check piston for scoring or cracks. Measure cylinder bore and determine if clearance is excessive.

2) Two grades of standard pistons are used; F and G. Identification mark is on piston head and block. One oversize piston is available; .001" (.025 mm). It will be necessary to hone cylinder to insert oversize piston.

3) Install expanding ring in bottom groove of piston with end butting, but not overlapping. Work from bottom of piston and fit bottom rail. Fit top rail into position going over head of piston. Install middle ring with "TOP" facing up. Put on upper compression ring. Stagger rings.

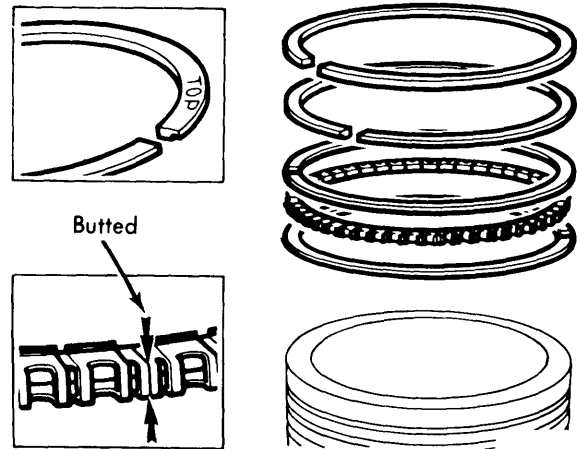

Fig. 4 Order and Detail of Piston Ring Installation

CRANKSHAFT MAIN & CONNECTING ROD BEARINGS							
Engine	MAIN BEARINGS				CONNECTING ROD BEARINGS		
	Journal Diam. In. (mm)	Clearance In. (mm)	Thrust Bearing	Crankshaft End Play In. (mm)	Journal Diam. In. (mm)	Clearance In. (mm)	Side Play In. (mm)
1493 cc	2.3115-2.3120 (58.713-58.725)	...	Rear	.004-.008 (.10-.20)	1.8750-1.8755 (47.625-47.638)

SPITFIRE 4 CYLINDER (Cont.)

MAIN & CONNECTING ROD BEARINGS

1) Remove engine, cylinder head and oil pan. Remove main and rod bearing caps. Slightly push up connecting rod assembly but do not dislodge it from cylinder. Remove upper connecting rod bearings.

2) Remove crankshaft and upper main bearings. Remove thrust washers from rear main bearing. Examine all bearing journals and determine if regrinding is necessary.

3) Examine each bearing and replace as required. Bearings are available in .010", .020", and .030" (.25, .51, and .76 mm) undersizes. Any undersize crankshaft which is installed or has been installed in service should have a size marking stamped in which corresponds to similar marking on bearings.

4) To install main and connecting rod bearings, reverse removal procedure, noting the following: bend over locking tabs, if equipped.

CRANKSHAFT END PLAY

NOTE — End play can be adjusted with engine installed in vehicle. Procedure given is with engine removed. Difference occurs as to where dial indicator is mounted.

Use a dial indicator and set it up as shown in Fig. 5. Measure end play by prying against crankshaft and reading dial indicator. Obtained value must lie within specifications. If end play is exceeded, fit oversize thrust washers to rear main bearing.

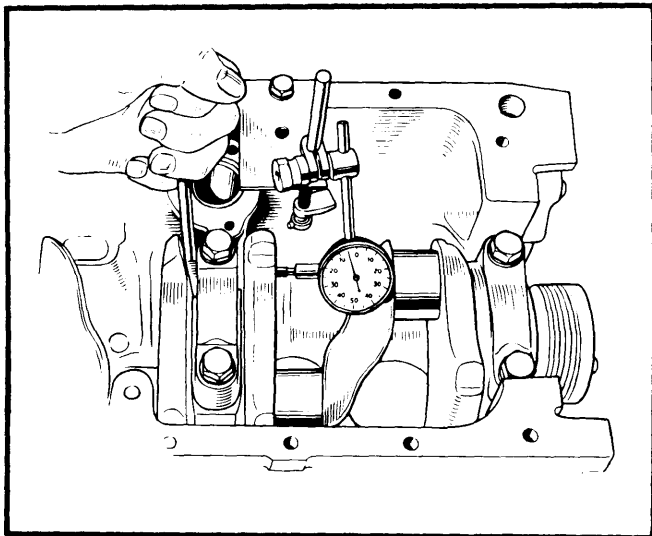

Fig. 5 Using a Dial Gauge to Check Crankshaft End Play

REAR MAIN BEARING OIL SEAL

1) Remove rear transmission adaptor plate. Remove two bolts attaching oil pan to seal housing and seven bolts attaching seal housing to crankcase. Remove seal housing and press out old seal.

2) Coat O.D. of seal with grease and press seal into housing with lip facing crankshaft. Install a new gasket coated with sealing compound. Carefully install seal housing with a plain copper washer on top bolt.

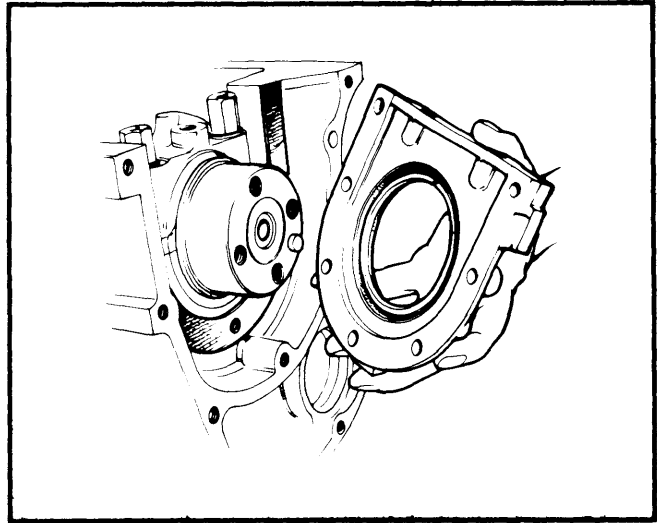

Fig. 6 Fitting Rear Main Bearing Seal Housing into Place

ENGINE FRONT COVER & OIL SEAL

Removal — Remove radiator. Remove left side inner fender panel. Remove air pump, alternator, fan, and crankshaft pulley. Remove air pump/alternator brackets, adjusting links and spacer. Take out timing cover mounting hardware. Loosen and remove cover. Press out old seal. Refit new seal with open side facing engine.

Installation — Note for installation that chain tensioner is inside cover. To facilitate cover installation, use a short piece of welding rod bent 90° to hold tensioner off chain.

CAMSHAFT In. (mm)			
Engine	Journal Diam.	Clearance	Lobe Lift
1493	1.9659-1.9664① (49.934-49.947)

① — Intermediate Journal 1.9649-1.9654" (49.908-49.921).

CAMSHAFT

Removal — 1) Disconnect battery. Remove radiator. Remove cylinder head. Remove water pump and fan. Remove alternator, air pump, crankshaft pulley, timing cover and chain.

2) Remove two bolts mounting camshaft keeper plate, then withdraw plate. Remove cam followers and index mark for reinstallation. Take out distributor drive shaft and gear. Remove fuel pump. Withdraw camshaft.

Installation — To install, reverse removal procedure and note the following: Lube camshaft bearing journals. Fit keeper plate with two bolts. Check camshaft end play. Pull camshaft

SPITFIRE 4 CYLINDER (Cont.)

against keeper plate and insert feeler gauge between camshaft and plate. End play must not exceed .004-.008" (.10-.20 mm). Oversize thrust plates are available to bring end play within specifications.

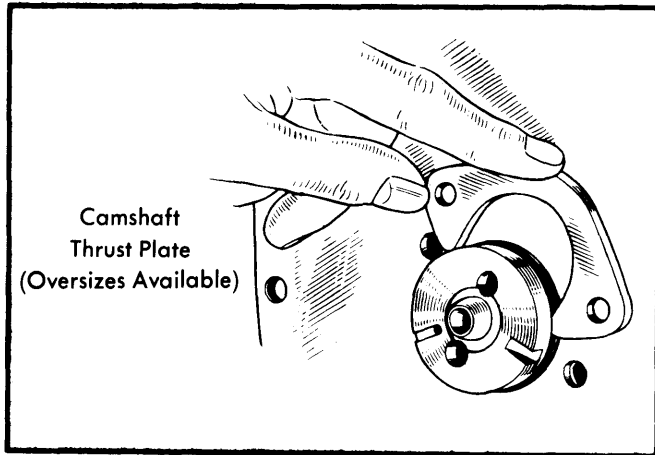

Fig. 7 Positioning Camshaft Thrust Plate

VALVE TIMING				
Engine	INTAKE		EXHAUST	
	Open (BTDC)	Close (ABDC)	Open (BBDC)	Close (ATDC)
1493 cc	18°	58°	58°	18°

TIMING CHAIN

Removal - 1) Disconnect battery. Remove timing chain cover. Take off oil thrower. Rotate crankshaft until index marks on crankshaft and camshaft sprockets align. Make sure crankshaft keyway is at 12 o'clock and that camshaft punch mark aligns with crankshaft keyway.

2) Bend back camshaft nut lock tabs and remove bolts mounting camshaft sprocket to camshaft. Remove camshaft sprocket and timing chain.

NOTE - DO NOT rotate camshaft or crankshaft while chain is off sprockets.

Installation - 1) Remove crankshaft key. Refit both sprockets. Check alignment with straightedge. Install selective fit shims to crankshaft if misalignment occurs. Install key.

2) Fit chain to sprockets. Install sprocket, keep index marks aligned. Slightly secure camshaft sprocket. Measure chain deflection along slack run of chain. $\frac{3}{8}$ " (9.53 mm) slack should not be exceeded. Reverse removal procedure for remaining components.

VALVE TIMING

1) Remove valve cover. Adjust No. 7 and No. 8 valves to .080" (2.03 mm) clearance. Turn crankshaft until No. 1 piston is at TDC, compression stroke (pulley "V" aligned with zero line on timing cover scale).

2) Insert feeler gauge between valve tip and rocker pad to make sure No. 1 and No. 2 valves are fully closed. Make sure No. 7 and No. 8 valve clearances are unchanged (use two feeler gauges). Move crankshaft as necessary to maintain equality.

3) Readjust No. 7 and No. 8 valves to and all other valves to .010" (.25 mm). Replace rocker cover.

NOTE - If chain or sprockets were removed, make sure timing marks are aligned when sprockets are reinstalled. See Timing Chain Removal and Installation.

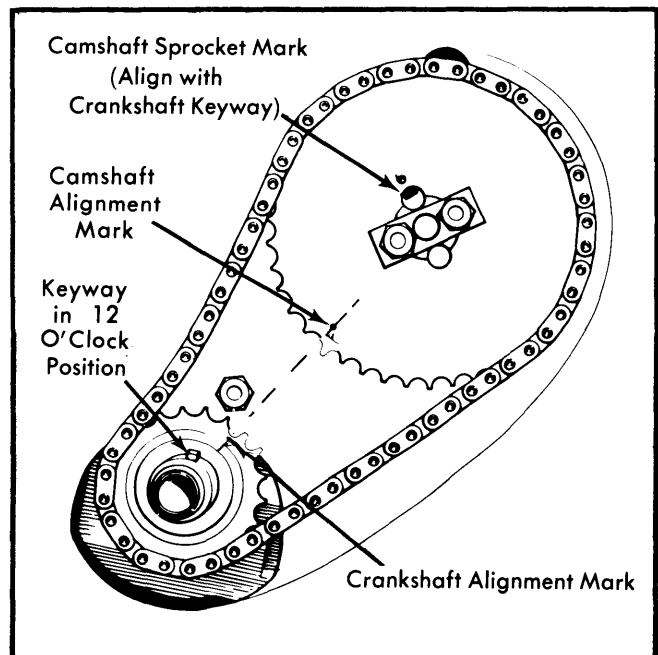

Fig. 8 Camshaft and Crankshaft Alignment Marks

ENGINE OILING

ENGINE OILING SYSTEM

Oil is drawn from engine by a rotor type pump which discharges via a nonadjustable relief valve to a full-flow filter. Cylinder bores, pistons and piston pins are splash lubricated all other components are oiled through drilled passages.

Crankcase Capacity (Drain and Refill) - 4.2 quarts.

Oil Filter - Disposable canister type.

Oil Pressure Relief Valve - Located in cylinder block beneath oil filter. Check relief valve spring free length; it should be 1.53" (38.8 mm).

OIL PUMP

1) Remove oil pan previously described. Remove three bolts securing oil pump to crankcase. Lift from vehicle and place in a vise.

2) Place a straightedge across pump body, then use a feeler gauge to check clearance between rotor face and straight edge; it should be .004" (.10 mm).

SPITFIRE 4 CYLINDER (Cont.)

ENGINE OILING (Cont.)

3) Check clearance between inner rotor and outer rotor. Clearance must not exceed .010" (.25 mm).

4) Check clearance between outer rotor and body; it must not exceed .008" (.20 mm).

5) Check cover plate for scoring, and test on a surface plate for distortion. Examine pump spindle bearing surface in body for excessive wear.

6) Reassembly oil pump installing any new parts as necessary to satisfy specifications. To install oil pump, reverse removal procedure.

ENGINE COOLING

Cooling System Capacity - 4.8 qts.

WATER PUMP

Drain cooling system. Remove radiator hoses, then unbolt and remove radiator. Detach fan belt. Unscrew three nuts securing water pump flange to thermostat and pump housing. Withdraw water pump. Remove fan. To install, reverse procedure.

TIGHTENING SPECIFICATIONS

Application	Ft. Lbs. (mkg)
Connecting Rod Bolts	
Color Dyed	50 (6.9)
Phosphated	46 (6.4)
Sprocket-to-Camshaft	24 (3.3)
Crankshaft Pulley Nut	150 (20.7)
Cylinder Head Bolts	46 (6.4)
Flywheel-to-Crankshaft	
Cadmium Plated Bolt	40 (5.5)
Parkarised Bolt	45 (6.2)
Intake-to-Exhaust Manifold	14 (1.9)
Manifold-to-Head	25 (3.5)
Main Bearing Cap Bolts	65 (9.0)
Oil Pan Bolts	20 (2.8)
Oil Seal Block Screw	14 (1.9)
Rocker Cover-to-Head	2 (0.3)
Rocker Shaft-to-Head	34 (4.7)
Rear Crankshaft Seal	20 (2.8)
Spark Plugs	20 (2.8)
Timing Cover-to-Front Plate	
3/8" Screw	10 (1.4)
7/8" Screw	20 (2.8)
Stud	16 (2.2)
Bolt	20 (2.8)
Water Pump-to-Head	20 (2.8)