

## R-12, 15 & 17 4 CYLINDER

GENERAL SPECIFICATIONS										
Year	Displ.		Carburetor	HP at RPM	Torque (Ft. Lbs. at RPM)	Compr. Ratio	Bore		Stroke	
	cu. ins.	cc					in.	mm	in.	mm
1976 843	100.5	1647	1x2-Bbl. ①	...	...	9.5-1	3.110	79	3.307	84

① — Fuel injection is used on Gordini models.

### ENGINE IDENTIFICATION

Engine number and type are given on a plate which is riveted to left side of engine block. Number is located just below cylinder head mating surface. First five digits indicate engine type.

#### Engine Codes

Application	Engine Code
R-12 Sedan & Wagon	
Man. Trans. ....	843-10
Auto. Trans. ....	843-11
R-15TL & R-17TL	
Man. Trans. ....	843-15
Auto. Trans. ....	843-16
R-17 Gordini.....	843-13

### ENGINE REMOVAL

1) Disconnect battery, remove hood and drain cooling system. Disconnect all water hoses, electrical leads, vacuum lines and fuel lines. Remove radiator, starter, camshaft pulley and drive belt.

2) Remove top engine-transmission mounting bolt(s). Remove tensioner, fan belt, crankshaft pulley, fuel inlet line, and fan. Disconnect exhaust pipe from manifold and transmission crossmember. Remove clutch shield.

3) Attach suitable hoist (Mot. 477) and take up engine weight. From left and right side, remove engine side mounts and bracket.

4) Raise engine until top of transmission just meets underside of steering crossmember. Suitably support transmission and remove two bottom engine-transmission assembly bolts. Remove engine from vehicle. To install, reverse removal procedure.

### INTAKE MANIFOLD

Disconnect battery and drain cooling system. Remove air filter and throttle linkage. Disconnect all necessary hoses, lines and electrical wires. Remove manifold nuts and remove manifold. To install, reverse removal procedure.

### CYLINDER HEAD

**Removal** — 1) Disconnect battery, drain cooling system and remove air filter. Disconnect all necessary water hoses, electrical wires and cable linkage. Remove distributor, alternator (with drive belt) and valve cover.

2) Remove water pump drive belt. Disconnect exhaust pipe at manifold and place out of way. Remove rubber rings and cups from spark plug tubes.

3) Loosen rocker arm adjusting screws and remove push rods. Remove cylinder head bolts and remove rocker arm assembly. Loosen cylinder head by tapping with a plastic hammer to rotate cylinder head in counterclockwise direction.

**NOTE** — If cylinder head is stuck, it will be necessary to pivot head on locating dowel on distributor side.

4) Lift cylinder head slightly and remove tappets, keeping them in order. Remove cylinder head. Install liner clamps to prevent any movement of liners.

**Installation** — 1) Remove liner clamp. Make sure all cylinder head bolt holes in block are free of excess oil so torque will not be affected. Check cylinder liner protrusion. See *Cylinder Liners*. New cylinder head gasket must be installed DRY.

2) Install locating studs. If proper equipment is not available for alignment, use hole just back of timing chain. Distributor gear alignment is dependent on correct cylinder head installation.

3) Install tappets in cylinder head and place head into position. Tap lightly to hold in place. Place rocker arm assembly in position and remove locating studs (if used). Install lubricated head bolts. Adjust valves. Install remaining components in reverse of removal procedure.

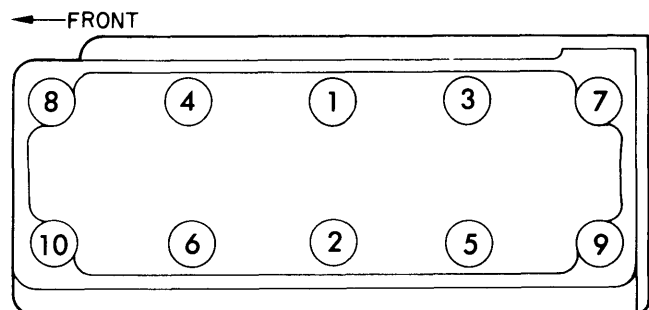

Fig. 1 Cylinder Head Tightening Sequence

# Renault Engines

## R-12, 15 & 17 4 CYLINDER (Cont.)

VALVES							
Engine & Valve	Head Diam. In. (mm)	Face Angle	Seat Angle	Seat Width In. (mm)	Stem Diameter In. (mm)	Stem Clearance In. (mm)	Valve Lift In. (mm)
843 Int.	1.378 (35.00)	45°	45°	.051-.063 (1.30-1.60)	.315 (8.00)	.....	.....
Exh.	1.220 (30.99)	45°	45°	.067-.079 (1.70-2.01)	.315 (8.00)	.....	.....

### VALVE ARRANGEMENT (R-17)

Right Side - All Exhaust  
Left Side - All Intake

### VALVE ARRANGEMENT (R-12 & 15)

E-I-I-E-E-I-I-E

### VALVE GUIDE SERVICING

1) Remove cylinder head and place on suitable support.

**NOTE** — Valve guide angles is 20° for both intake and exhaust valves.

2) Measure worn guide and replace with the nearest oversize. Standard valve guide diameter is .512" (13 mm). First oversize guide is .516" (13.10 mm) and is identified by one index mark. The second oversize guide is .522" (13.25 mm) and is identified by two index marks.

3) Turn cylinder head over, and using suitable reamer, ream bore in head to accept new guide. Lubricate new valve guide and install with chamfer facing outward. Using suitable reamer, ream valve guide bore. **NOTE** — After replacing valve guide, ream corresponding valve seat.

**Cylinder Head Removed** — Using suitable tool (U43P), compress valve spring and remove keepers, top cups, springs and base washers. To install, reverse removal procedure.

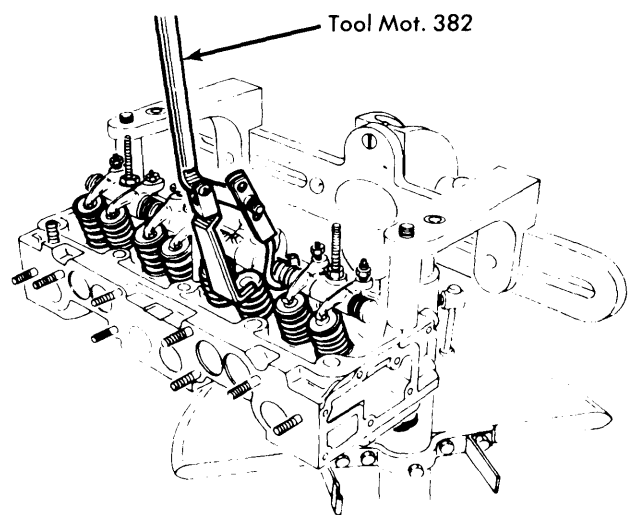

Fig. 2 Position of Valve Spring Removal Tool on Head

VALVE SPRINGS			
Engine	Free Length	PRESSURE (LBS.)	
		Valve Closed	Valve Open
Outer	1.905 (48.39)	...	99@1.142 (44.91@29.01)
Inner	1.512 (38.40)	20@.75 9.07@19.05	...

### VALVE SPRING REMOVAL

**Cylinder Head Installed** — 1) Disconnect battery and remove valve cover. Bring piston to TDC and remove push rod corresponding to spring requiring maintenance.

2) Using suitable tool (Mot.382), compress valve spring and remove retainer, top cup, and spring. Spring can now be further checked. To install, reverse removal procedure.

**NOTE** — Valve springs must be fitted with larger coil spacing toward cylinder head.

### ROCKER ARM ASSEMBLY

After disassembling, cleaning, and inspecting rocker shaft components, ensure they are properly reassembled (see illustration). Correct order is: rocker shaft bracket, rocker arm, spring, and rocker arm. Align rocker shaft with oil holes facing push rod side. Bracket holes must line up with holes in rocker shaft.

### VALVE TAPPET SERVICE

1) With tappets removed, thoroughly clean tappets and tappet bores in cylinder head. Check clearance between tappets and cylinder head bores.

2) If clearance is excessive, tappet bores must be reamed for oversize tappets. Tappets are available in .008" (.20 mm) oversize. Ream tappet bores to .480" (12.2 mm) if installing new tappets.

### VALVE CLEARANCE

Adjust intake valve clearance to .008" (.20 mm) and exhaust valve clearance to .010" (.25 mm) on all models except Gordini. Adjust both intake and exhaust valves to .010" (.20 mm) on all Gordini models.

## R-12, 15 & 17 4 CYLINDER (Cont.)

PISTONS, PINS, RINGS						
Engine	PISTONS	PINS		RINGS		
	Clearance In. (mm)	Piston Fit In. (mm)	Rod Fit In. (mm)	Rings	End Gap In. (mm)	Side Clearance In. (mm)
All	.....	Free Fit	Press Fit	.....	①	.....

① — Pre-set gap, do not alter.

### OIL PAN REMOVAL

Raise vehicle and drain crankcase. Extract oil pan bolts and ease pan from its position. It may be necessary to remove clutch shield. To install, reverse removal procedure. **NOTE** — Ensure oil pan contact surface is scraped clean before installing new gasket.

### CYLINDER LINERS

**Removal** — 1) Disconnect battery and drain cooling system and oil pan. Remove cylinder head and install liner clamps. See *Cylinder Head*. Remove oil pan and oil pump.

2) Mark connecting rods on cam side, number one at clutch end. Remove connecting rod caps and bearings. Remove liner clamp and remove liner-piston-rod assembly.

**Installation** — **NOTE** — Before installing pistons in liners, protrusion of liner above cylinder block gasket face must be measured.

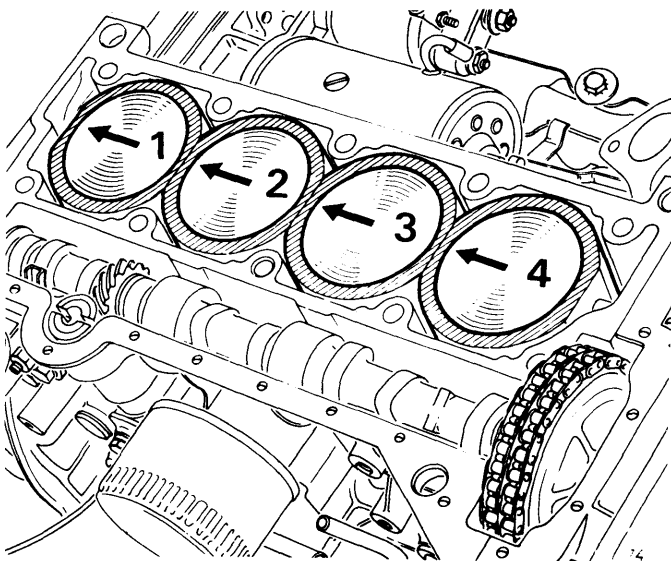

Fig. 3 Showing Cylinder Liners Installed in Block

1) Protrusion should be .004-.067" (.10-.170 mm) when checked without "O" ring seal. Various size seals are available to correct protrusion height (if necessary).

2) Install piston and rod assembly in liner. See *Piston & Rod Assembly*. Install piston-rod-liner assembly into cylinder block. **NOTE** — Number one is at clutch end, arrow points to flywheel and number on connecting rod is on cam side.

3) Lubricate bearings and replace connecting rod caps. Replace remaining components in reverse of removal taking care not to disturb liner bottom seals.

### PISTON & ROD ASSEMBLY

**Removal** — Piston and connecting rods are removed from cylinder block with cylinder liners. See *Cylinder Liners*. Remove piston through bottom of liner and remove rings, piston pin and connecting rod. See *Piston Pins*.

**Installation** — 1) Replace connecting rod and piston pin. **NOTE** — Piston must be assembled with arrow on piston pointing downward. Number stamped on connecting rod journal must face right with top of piston toward installer.

2) Replace piston rings spacing gaps 120° apart. See *Fitting Pistons*. Using suitable ring compressor (Mot.442) push piston through bottom of cylinder liner with flat on side of liner parallel with sides of connecting rod.

### FITTING PISTONS

Pistons, rings and liners are matched sets and must never be interchanged. All piston ring clearances and gaps are preset and must not be altered. See *Piston and Rod Assembly*.

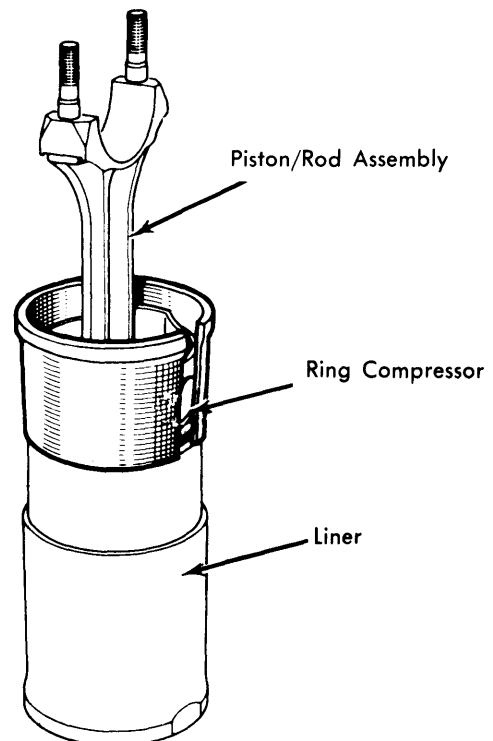

Fig. 4 Inserting Piston into Liner Using Ring Compressor

## R-12, 15 & 17 4 CYLINDER (Cont.)

### PISTON PIN REPLACEMENT

- 1) After removing Piston assembly from liner, remove rings. Using suitable tool (Mot. 255) shown in Fig. 5 piston can be removed. Extract pin with appropriate adaptors.
- 2) Check connecting rod for wear or damage. Before preparing new piston, ensure pin is a running fit in piston.

- 3) Heat connecting rod in water to boiling point or in an oven to 482°F.
- 4) Slide new piston over installing mandrel and screw locating plug into place. Apply Molykote M 55 to piston pin. Push mandrel pin guide pin assembly through piston, by hand, until piston pin makes contact with connecting rod. Ensure piston and connecting rod are being fitted correctly (see illustration). Place assembly under hydraulic press and carefully seat pin into position.

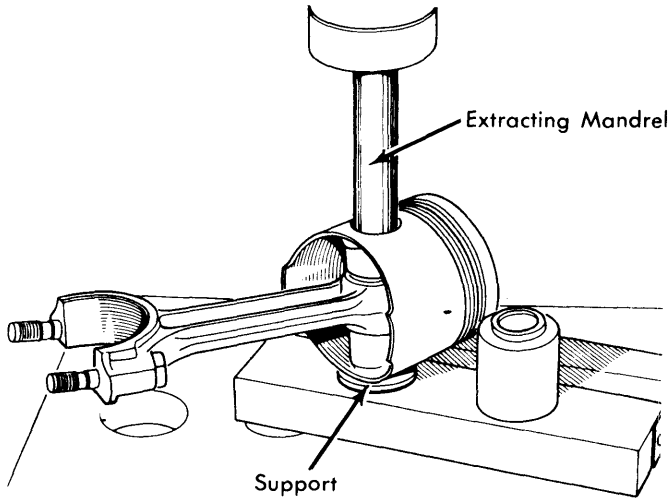

Fig. 5 Special Tool Assembly Mot. 255 for Extracting Piston Pin

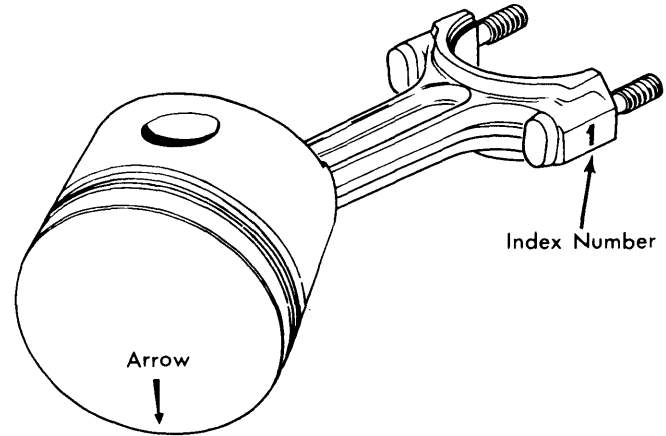

Fig. 6 Piston and Connecting Rod Assembly with Detail of Index Markings

CRANKSHAFT MAIN & CONNECTING ROD BEARINGS							
Engine	MAIN BEARINGS				CONNECTING ROD BEARINGS		
	Journal Diam. In. (mm)	Clearance In. (mm)	Thrust Bearing	Crankshaft End Play In. (mm)	Journal Diam. In. (mm)	Clearance In. (mm)	Side Play In. (mm)
843	2.158 (54.81)	.....	No. 3	.002-.009 (.05-.23)	1.89 (48.0)	.....	.012-.022 (.32-.56)

### MAIN BEARING SERVICE

- 1) With cylinder head and oil pan removed, invert engine so crankshaft is exposed. Remove connecting rod bearing caps. Mark position of main bearing caps to cylinder block. Remove all except front main bearing cap.
- 2) Push up front main bearing by lightly tapping on lower corners. Remove seal and bearing.
- 3) Remove crankshaft, bearings, and thrust washers. With crankshaft removed, pilot bearing can be replaced.
- 4) Check crankshaft, connecting rod bearings, and main bearings for wear. If crankshaft diameter is found out of tolerance, it may be ground to fit .010" undersize main and connecting rod bearings.

**NOTE** - Crankshaft and connecting rod journals are roll hardened.

- 5) Fit upper main bearings (those with oil holes). Lubricate main bearing journals and fit crankshaft into position. Fit thrust washers, white metal toward crankshaft. Fit bearings to main bearing caps. Numbers 2, 3, 4, and 5 do not have oil holes. Fit

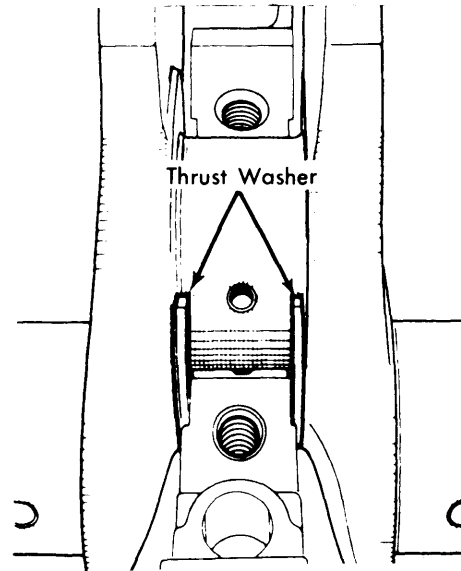

Fig. 7 Crankshaft Thrust Washers in Fitted Position

## R-12, 15 & 17 4 CYLINDER (Cont.)

main bearings caps into position aligned with previously made reference marks. Carefully install No. 1 main bearing cap and seals. **NOTE** — Correct fit is imperative.

6) Fit upper connecting rod bearings and rod over crankshaft. Install rod caps and tighten to specification.

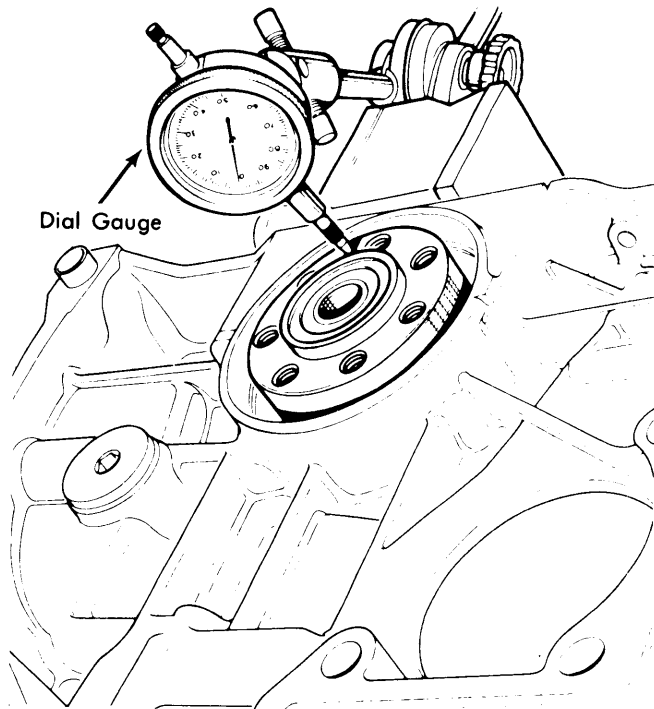

Fig. 8 Using a Dial Gauge to Measure Crankshaft End Play

7) Using a dial gauge, check crankshaft end play. Float must not exceed .009" (.23 mm). If correct end play is not obtained, replace thrust washers. Thrust washers are available in standard and two oversizes.

### REAR MAIN BEARING OIL SEAL

**NOTE** — Because lip of seal is extremely delicate, exercise caution.

Fit seal on suitable tool (Mot.259-01) and lubricate outside. Install seal by lightly tapping shaft of installer tool. Seal is fully seated when tool just touches crankshaft.

### REAR MAIN OIL SEAL

**Engine Installed** — 1) Loosen fan belt, unlock and unscrew pulley mounting bolt. Remove pulley and extract oil seal.

2) To install seal, fit oil seal over suitable tool (Mot. 525), align seal, and screw bolt in until tool just meets timing chain cover. Reverse removal procedure for remaining components.

### CAMSHAFT

**NOTE** — Camshaft specifications not available at time of publication.

### TIMING CHAIN

**Removal** — 1) With engine removed and suitably supported, remove timing cover and timing chain tensioner. Remove camshaft sprocket retaining bolts, washer and thrust ring.

2) Remove chain damper and camshaft securing bolts. Withdraw crankshaft sprocket and chain, using suitable puller (Mot.49), while easing camshaft forward. **NOTE** — It is not necessary to completely remove camshaft to remove chain.

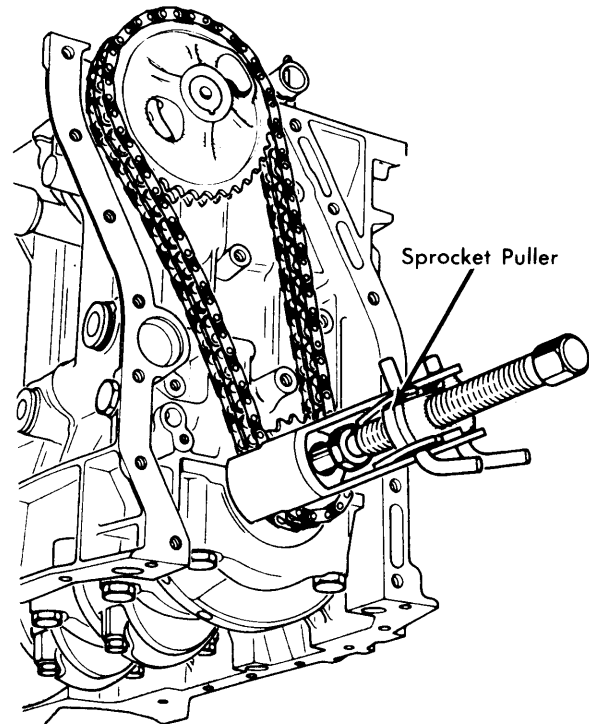

Fig. 9 Using Puller to Remove Crankshaft Sprocket

**Installation** — 1) Position chain on camshaft sprocket. Align camshaft sprocket timing mark with centers of crankshaft and camshaft. Turn crankshaft, bringing key upward.

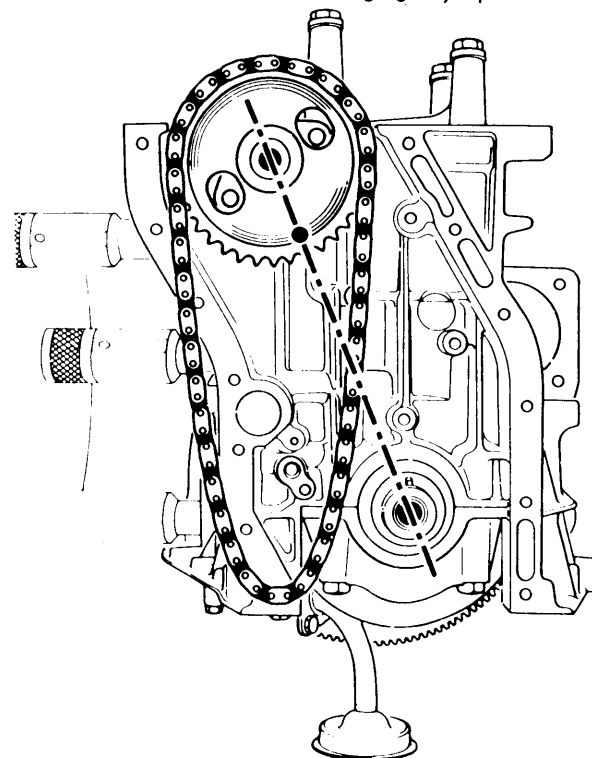

Fig. 10 Camshaft Sprocket Alignment Before Timing Chain Installation

## R-12, 15 &amp; 17 4 CYLINDER (Cont.)

2) Fit crankshaft sprocket on chain (timing mark facing outward), keeping timing marks in line. Using suitable tool, install crankshaft sprocket while sliding camshaft into place.

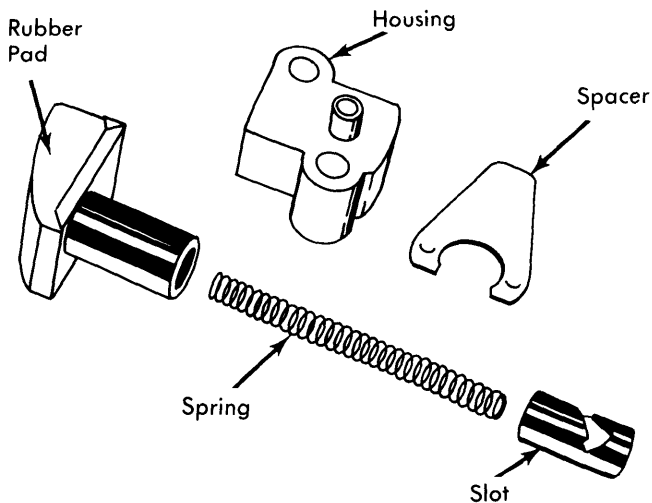

Fig. 11 Exploded View of Timing Chain Tensioner

3) Replace chain damper and camshaft mounting bolts. Adjust tensioner. Remove plastic spacer (red). Push rubber pad until it contacts housing. Lock pin is now disengaged from slot in retainer. Place rubber pad under spring tensioner.

### CAMSHAFT REMOVAL

1) Remove and suitably support engine. Remove (in order) cylinder head, distributor drive gear, oil pan, timing chain cover, camshaft rear bearing, timing chain and camshaft. Camshaft is secured by two bolts accessible through pulley.

**NOTE** – Camshaft and distributor drive gear are replaced as a set. Camshaft sprocket must be replaced at each disassembly.

2) To install, position a new flange key. Using suitable press, fit sprocket, taking load behind first camshaft bearing. Reverse removal procedure for remaining components.

### ENGINE OILING

**Crankcase Capacity** – All models, 4.2 quarts. With filter change, 4.5 quarts.

**Oil Filter** – Disposable canister type.

**Normal Oil Pressure** – 30 psi at idle and 60-70 psi at 4000 RPM.

**Pressure Regulator Valve** – Located in oil pump.

### OIL PUMP

1) With engine and oil pan removed, oil pump can be disassembled. Remove cotter pin retaining relief valve, and lift out cup, spring, spring guide, and piston.

2) Clean all parts and inspect relief valve assembly. Check inner and outer rotors for damage.

VALVE TIMING				
Engine	INTAKE		EXHAUST	
	Open (BTDC)	Close (ALDC)	Open (BLDC)	Close (ATDC)
843	10°	42°	46°	10°

### VALVE TIMING

Ensure crankshaft and camshaft timing marks are aligned. Check timing chain tension adjustment, see Fig. 12.

**NOTE** – When chain is in normal position, a line passing through timing marks will not quite bisect camshaft.

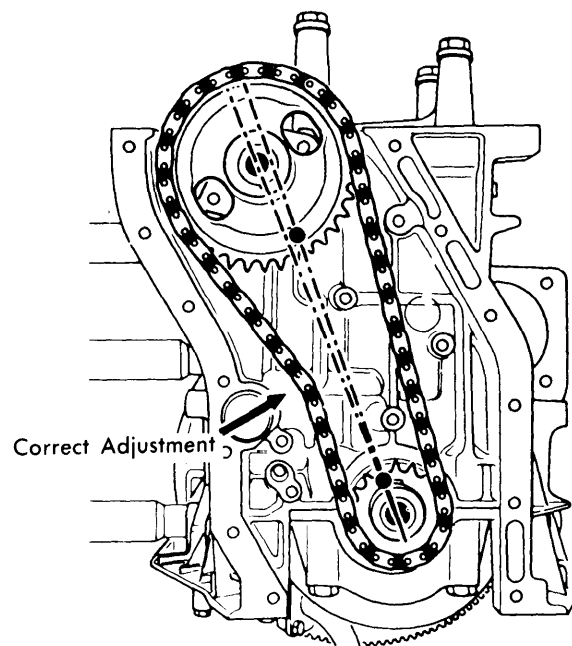

Fig. 12 Camshaft and Crankshaft Alignment with Chain Installed

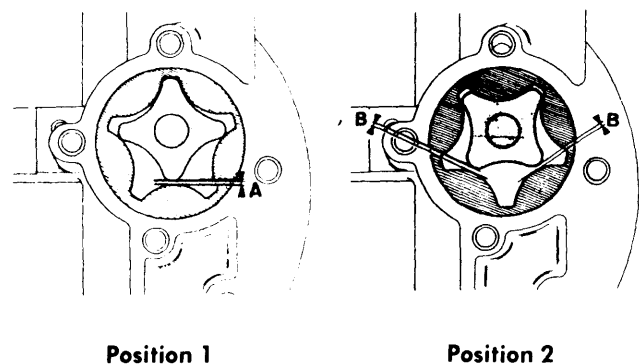

Fig. 13 Measurement Points for Oil Pump Rotor Clearance

## R-12, 15 & 17 4 CYLINDER (Cont.)

### ENGINE OILING (Cont.)

3) Measure tip clearance in both positions shown in Fig. 13. Clearance in "POSITION 1" must be .002-.012" (.05-.30 mm) and .001-.006" (.03-.15 mm) in "POSITION 2". If either tolerance is exceeded, rotors must be changed.

4) To reassemble, fit piston, spring guide, spring, and cup in position. Install retaining cotter pin, strainer flange seal, strainer and lock tab. Tighten all bolts.

**NOTE** — It is possible to remove oil pump cover and rotor without removing engine.

### ENGINE COOLING

**Cooling System Capacity** — R-12, 9½ quarts. R-15 and R-17TL, 7 quarts. Gordini, 8 quarts.

pansion bottle after engine has cooled. Change expansion valve if coolant has passed through valve.

#### WATER PUMP

Disconnect battery and drain cooling system. Remove water pump and alternator drive belts. Remove all necessary water hoses. Remove both water pump and camshaft pulleys. Remove water pump. To install, reverse removal procedure.

**NOTE** — If water pump is hard to free, tap it with a plastic hammer.

#### COOLING SYSTEM REFILL & BLEEDING

1) Open bleed screws located on carburetor (R-12 models) or on engine block and in upper radiator hose. Clamp radiator hose between block and bleeder valve. Make sure hose is shut off as close to water pump as possible.

2) Run engine at about 1500 RPM (fast idle). When air bubbles stop, close bleeder valves. Fill radiator and replace cap. Run engine until thermostat has fully opened. Check ex-

### TIGHTENING SPECIFICATIONS

Application	Ft. Lbs. (mkg)
Cylinder Head	
Step 1.....	30 (4.15)
Step 2.....	50-55 (6.91-7.60)
Step 3.....	① 55-60 (7.60-8.30)
Main Bearings.....	45 (6.22)
Intake & Exhaust Manifolds.....	25 (3.46)
Connecting Rods.....	30 (4.5)
Crankshaft Bolt.....	45-50 (6.22-6.91)
Camshaft Sprocket.....	15 (2.07)
Rocker Shaft Nuts.....	15-20 (2.07-2.77)
Flywheel.....	36 (5.0)

① — After engine has been run for at least 10 min. and been allowed to cool for 50 min.