

Peugeot Engines

504 GASOLINE 4 CYLINDER

GENERAL SPECIFICATIONS										
Year	Displ.		Carburetor	HP at RPM	Torque (Ft. Lbs. at RPM)	Compr. Ratio	Bore		Stroke	
	cu. ins.	cc					in.	mm	in.	mm
1976	120.2	1970	2x1-Bbl.	8.0-1	3.464	88	3.189	81

ENGINE IDENTIFICATION

Engine serial number is stamped on left side engine mounting face and is also located on the identification plate attached to right inner fender panel.

Engine identification number is stamped on camshaft tunnel. The first letter and five digits designate production number. The last letter is an identification letter and is decoded as follows:

Application	Transmission	Engine Code
XN1 Engine	Manual	UA
XN1 Engine	Automatic	XA

ENGINE REMOVAL

1) Remove battery, battery tray and hood. Remove radiator, ignition coil, starter, and windshield bottle. Disconnect heater hoses, fuel feed lines, carburetor controls, vacuum lines and electrical wiring. On automatic transmission models, drain transmission and disconnect transmission dip stick bracket from cylinder head.

2) Remove air cleaner. Lower steering rack housing. Disengage exhaust pipe from manifold. Remove flywheel covering and clutch housing bolts. Attach a suitable hoist to engine and take up weight.

3) Remove four bolts attaching engine mounts to crossmember. **NOTE** - Ensure left hand brake line is against crossmember. Raise engine until transmission meets tunnel. Suitably support transmission.

4) On automatic transmission models, remove four bolts connecting converter to flywheel. **NOTE** - Never remove engine with converter, converter must remain attached to transmission. Lift engine from compartment. To install engine, reverse removal procedure.

CYLINDER HEAD

Removal - 1) Drain cooling system. Remove air cleaner and support, carburetor and linkage. Remove distributor cap and wires, and remove spark plugs. Remove upper radiator hose and water pump drive belt. Disconnect alternator bracket from cylinder head.

2) Disconnect heater hose from water pump and hose bracket from cylinder head. Disconnect oil supply line at rear of head. Disconnect remaining electrical leads and water hoses. Remove exhaust pipe from manifold.

3) Remove spark plug tube seals and their cups. Remove two cylinder head bolts from position number eight and nine and replace with guide studs. Remove remaining cylinder head

bolts and remove rocker arm assembly. Remove push rods and place in order for proper installation.

4) Remove the forward guide stud (number eight) and pivot cylinder head on remaining guide to loosen cylinder head from gasket. **CAUTION** - Cylinder head gasket sticks to cylinder head, cylinder block and liners. No attempt must be made to lift cylinder head until it has been loosened, otherwise liner seats will be loosened and liner gaskets damaged.

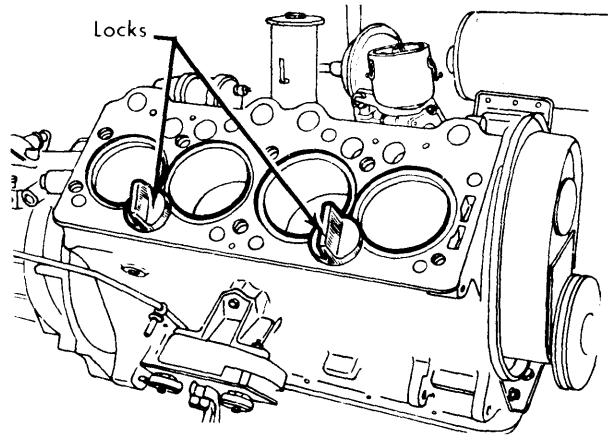

Fig. 1 Cylinder Liner Locks Installed in Position

5) Lift cylinder head to remove. Remove gasket and remaining guide stud. Install suitable liner clamps to prevent any movement of cylinder liners.

Installation - 1) Remove liner locks and ensure inner flats of liners are parallel on liners 1-2 and 3-4. Install cylinder head guide studs. Install new gasket dry with word "DESSUS" facing up. Place cylinder head in position and replace push rods.

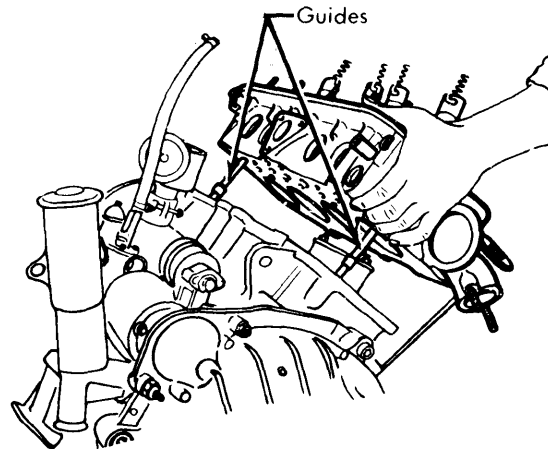

Fig. 2 Fitting Cylinder Head to Engine Block

504 GASOLINE 4 CYLINDER (Cont.)

2) Replace rocker arm assembly on studs, do not tighten nuts. Lubricate cylinder head bolts and install in position, tightening slightly. Tighten cylinder head bolts in sequence to 36 ft. lbs. (5 mkg), then tighten rocker arm assembly nuts to 11 ft. lbs. (1.5 mkg).

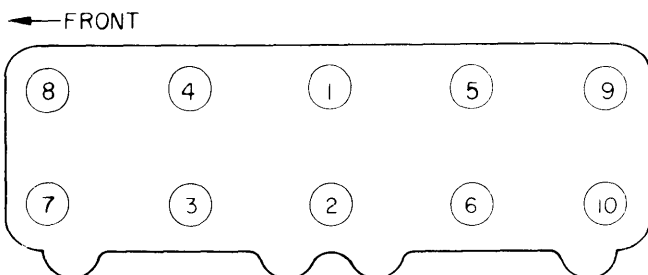

Fig. 3 Cylinder Head Bolt Tightening Sequence

3) Loosen number one cylinder head bolt and retighten to 14.5 ft. lbs. (2 mkg), then continue to tighten the bolt for an additional 90° (one quarter turn). Using same procedure, loosen and tighten remaining head bolts in sequence. **NOTE** — If in doubt about the tightening of any one bolt, loosen completely and repeat all above operations.

4) Adjust valves to .006" (.15) for intake and .012" (.30) for exhaust. See Valve Clearance Adjustment. After 600 miles, adjust valves to standard clearances.

5) **NOTE** — Cylinder head bolts **MUST** be retightened after 600 miles. To retighten cylinder head bolts, loosen bolt

number one completely and retighten according to instructions outlined previously. Follow this same procedure for remaining bolts, working in sequence. Retighten rocker arm assembly nuts.

SPARK PLUG TUBE REPLACEMENT

1) With cylinder head supported, screw in plugs without springs, to prevent dirt from dropping into cylinder.

2) Using suitable extractor or hammer, remove tubes. **NOTE** — If tubes are removed they can not be reused.

3) To install tubes, smear suitable sealing compound on tubes and insert them so plug caps are facing as shown in illustration. When tube is fully seated it will protrude 2.835" (72 mm) upward from cylinder head.

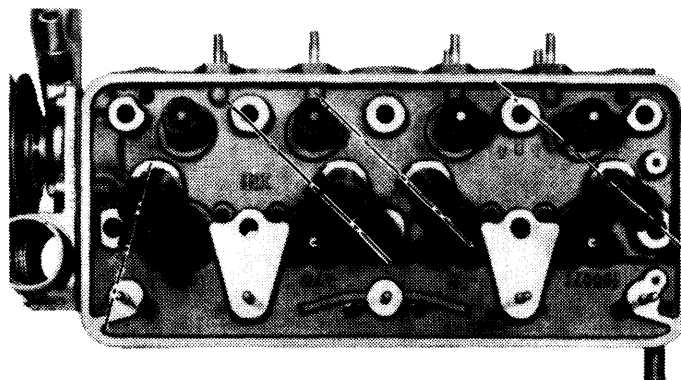

Fig. 4 Position of Spark Plug Tubes for Installation

VALVES							
Engine & Valve	Head Diam. In. (mm)	Face Angle	Seat Angle	Seat Width In. (mm)	Stem Diameter In. (mm)	Stem Clearance In. (mm)	Valve Lift In. (mm)
1970 cc Int.	1.673 (42.49)	...	30°3157 (8.019)
Exh.	1.398 (35.51)	45°	45°3150 (8.001)

VALVE ARRANGEMENT

Left Side — Intake valves.

Right Side — Exhaust valves.

NOTE — Cylinders and valves are numbered with number one at flywheel end.

VALVE SPRINGS			
Engine	Free Length In. (mm)	PRESSURE Lbs. @ In. (kg @ mm)	
		Valve Closed	Valve Open
1970 cc Outer	...	137@1.213 (62.1@30.8)	35@1.566 (15.9@39.8)
Inner	...	69@1.055 (31.3@26.8)	18@1.409 (8.16@35.7)

VALVE SPRING REPLACEMENT

Intake Valve — Turn crankshaft in direction of engine rotation and position where exhaust valve just begins to open. Slide rocker arm off intake valve then bring piston to TDC of compression stroke. Using suitable spring compressor, compress spring and remove keepers, spring retainer and spring.

Exhaust Valve — 1) Remove spark plug from cylinder requiring attention. Rotate crankshaft in direction of engine rotation and bring intake valve to fully closed position. Slide rocker arm off exhaust valve.

2) Insert suitable hinged tool (0 0136) into spark plug hole and bring piston to TDC without forcing as tool is between piston and valve. Using suitable spring compressor, compress spring and remove keepers, spring retainer and spring.

504 GASOLINE 4 CYLINDER (Cont.)

VALVE CLEARANCE ADJUSTMENT

NOTE — Engine must be allowed to cool at least six hours before adjusting valves.

Rotate engine until exhaust valve number one is fully opened, then adjust intake valve number three and exhaust valve number four. Rotate engine one half turn until next number valve is fully opened and adjust corresponding valves. See table. Continue until all valves have been adjusted.

Valve Adjustment Sequence

Valve Open	Adjust Valves
E 1.....	I 3 & E 4
E 3.....	I 4 & E 2
E 4.....	I 2 & E 1
E 2.....	I 1 & E 3

Valve Clearance Adjustment

Application	Intake In. (mm)	Exhaust In. (mm)
All Models.....	① .004.....	.010
.....	(.10).....	(.25)

① — Set No. 1 and No. 4 Intake to .008" (.20 mm).

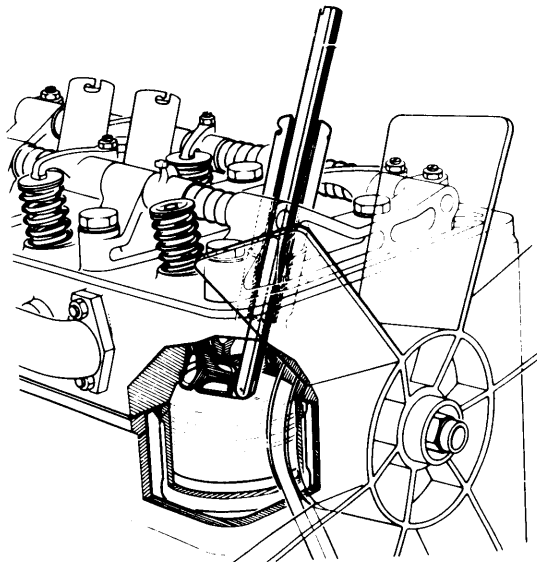

Fig. 5 Removing Valve spring with Valve Held in Place

PISTON & ROD ASSEMBLY

NOTE — If liners and pistons are to be replaced, engine must be removed.

1) Drain crankcase. With engine suitably supported on an engine stand, remove intake and exhaust manifolds. Remove all auxiliary equipment to point shown in illustration.

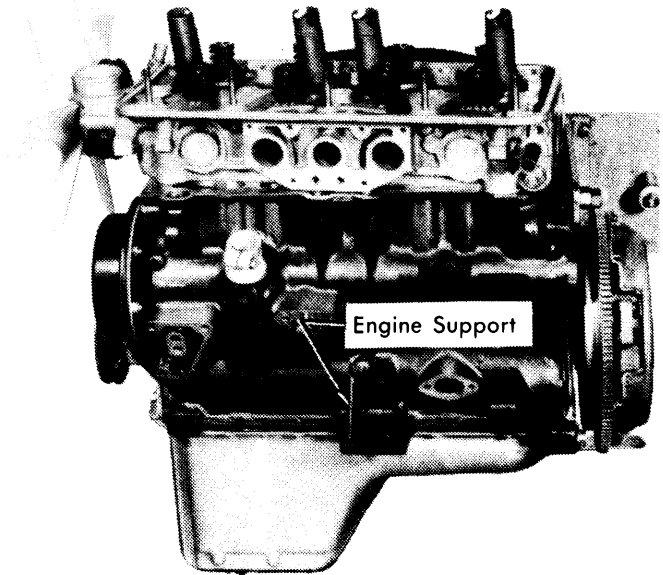

Fig. 6 View of Engine with Auxiliary Equipment Removed

2) Remove cylinder head. See *Cylinder Head Removal*. Remove camshaft hydraulic lifters, keeping them in original order. Remove distributor support drive shaft.

3) Remove oil pan and oil pump. Extract timing cover. Remove bearing caps noting order. Remove pistons and connecting rods. Mark rod assemblies 1-4.

4) To install, fit piston ring clamp on piston. Insert piston and rod assembly, without twisting it. Ensure index arrow is facing front of engine.

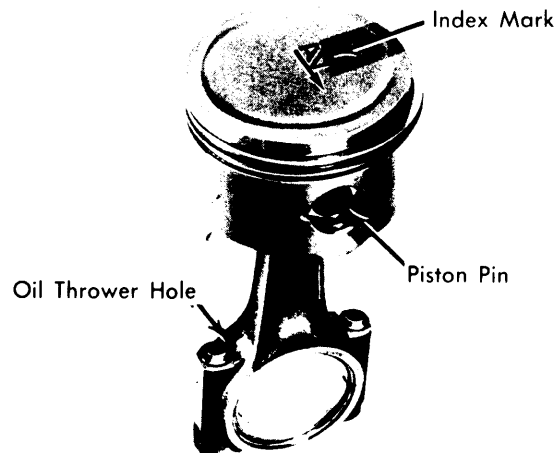

Fig. 7 Piston and Rod Assembly with Index Marks Noted

5) Push piston down cylinder and guide connecting rod with bearing over crankshaft journal. Install bearing cap and tighten to specifications.

FITTING CYLINDER LINERS

1) Before installing, liners must be dirt free. **NOTE** — Do not alter piston/liner pairings. Insert liners, without base gaskets, with flats on shoulder of liners 1-2 and 3-4 parallel.

504 GASOLINE 4 CYLINDER (Cont.)

2) Place a suitable dial gauge and support on block face. Synchronize dial at 0 and 5. Check each liner at four different points, noting the highest reading.

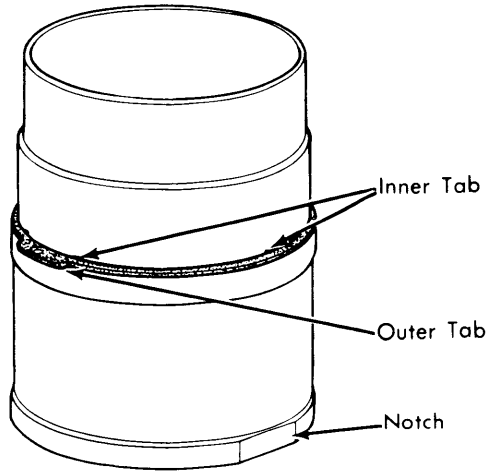

3) The maximum allowable difference between two diametrically opposed points must be less than .003" (0.07 mm). If specification is exceeded, it may be necessary to change position of liners. **NOTE** - Suitably mark liners.

4) Select a base gasket for each liner which will give a protrusion of approximately .004" (0.11 mm). **NOTE** - Only use one gasket on each liner.

5) Fit gasket on liner. Engage gasket inner tabs in liner grooves (see illustration). Position tab with reference mark at right angles to flat. Position liners with outer tabs in position as shown in illustration.

6) Fit suitable liner compressor tools (8.0128) to block, seat liners and ensure protrusion is correct. **NOTE** - Difference in protrusion of adjoining cylinders must not exceed .016" (.04 mm).

PISTON PIN REPLACEMENT

Fit piston to rod so that index mark "AV" is at right angles to oil thrower. Insert piston pin, it may be necessary to heat piston to install pin. Install snap rings.

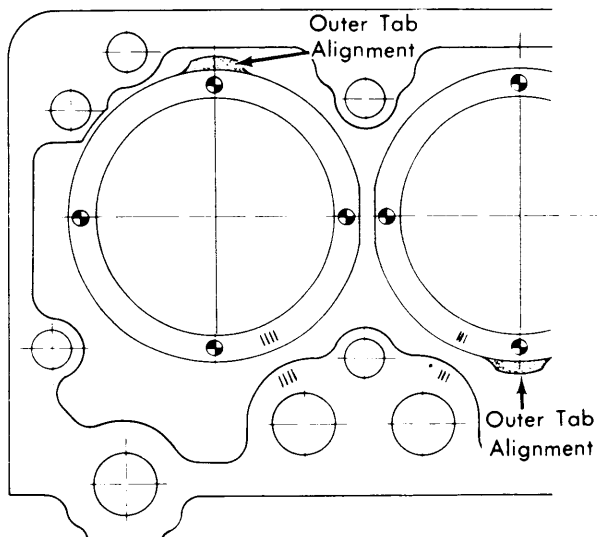

Fig. 8 Fitting Cylinder Liner Gasket to Liner

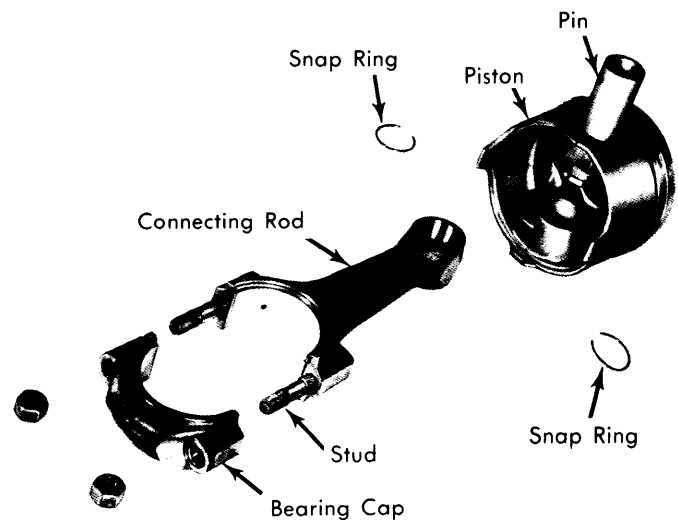

Fig. 9 Exploded View of Piston and Connecting Rod

CRANKSHAFT MAIN & CONNECTING ROD BEARINGS							
Engine	MAIN BEARINGS				CONNECTING ROD BEARINGS		
	Journal Diam. In. (mm)	Clearance In. (mm)	Thrust Bearing	Crankshaft End Play In. (mm)	Journal Diam. In. (mm)	Clearance In. (mm)	Side Play In. (mm)
1970 cc							
No. 1 (Rear)	2.1616-2.1646 (54.905-54.980)	...	Rear	.003-.008 (.08-.20)	2.1123-2.1131 (53.652-53.673)	.0006-.003 (.016-.076)
No. 2	2.2102-2.2112 (56.140-56.165)						
No. 3	2.2509-2.2515 (57.174-57.189)						
No. 4	2.3050-2.3060 (58.548-58.573)						
No. 5 (Front)	2.3386-2.3392 (59.401-59.416)						

504 GASOLINE 4 CYLINDER (Cont.)

THRUST BEARING WASHERS

After installing crankshaft, check end play. Play must not exceed .008". If specification is exceeded, oversize thrust washers are available in .094" (2.40mm), .096" (2.45mm) and .098" (2.50mm).

VALVE TIMING				
Engine	INTAKE		EXHAUST	
	Open (ATDC)	Close (ALDC)	Open (BLDC)	Close (ATDC)
1970 cc	2°	39°	30°	8° 30'

TIMING CHAIN REMOVAL

1) Remove radiator, fan belt and spark plugs. Remove crankshaft pulley and timing chain cover (see illustration). Disengage chain tensioner by removing plug and turn 3mm Allen wrench clockwise. It is possible to further disassemble chain tensioners.

NOTE — Position camshaft as shown in illustration to avoid any possible contact of valves and pistons when rotating crankshaft with timing chain removed.

2) Remove camshaft sprocket, timing chain, crankshaft sprocket and Woodruff key.

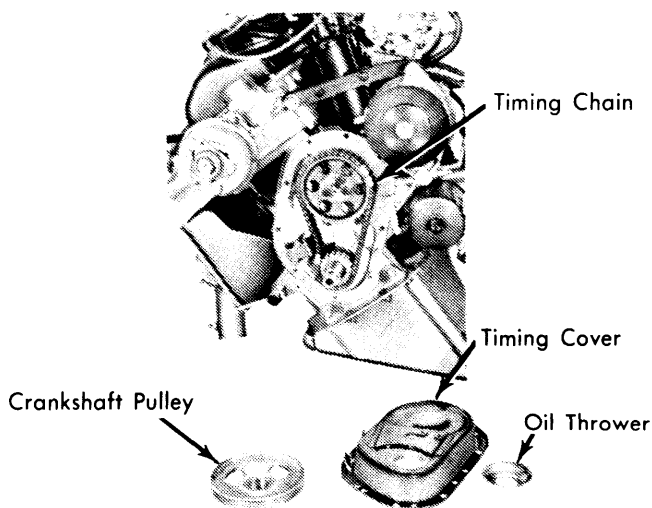

Fig. 10 Timing Cover Removed with Related Components

3) Begin installation by holding crankshaft in original position and installing Woodruff key and sprocket. Position camshaft and then crankshaft as shown in illustration.

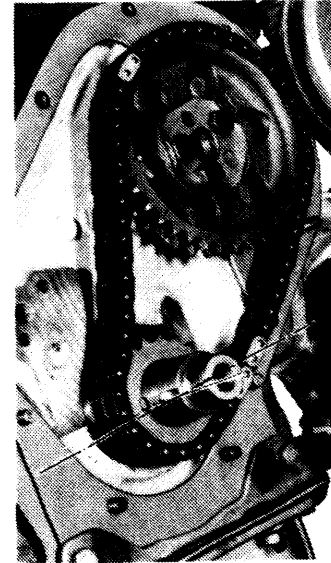

Fig. 11 Correct Position of Crankshaft for Chain Installation

4) Install timing chain first on camshaft sprocket, then on crankshaft sprocket. Ensure timing marks are in correct alignment. Fit camshaft with a new washer and tighten bolts. Bend up tabs.

5) Engage chain tensioner by adjusting Allen wrench in a clockwise manner. Install a new tab washer on plug and bend tab. Withdraw tool after installing tensioner.

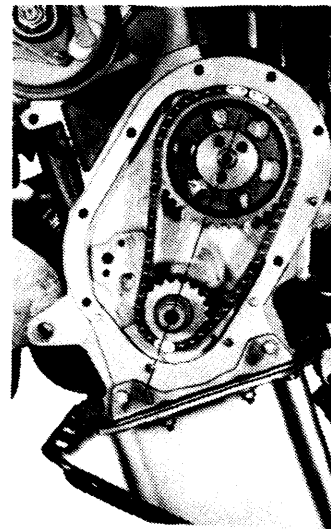

Fig. 12 Proper Alignment of Camshaft and Crankshaft

6) Install thrust washers, if necessary, oil slinger cap, and timing chain cover. Center timing chain cover with suitable tool (0128). Fit crankshaft pulley.

504 GASOLINE 4 CYLINDER (Cont.)

ENGINE OILING

Crankcase Capacity – Approximately 4.2 qts.

Oil Filter – Full-flow cartridge type.

Normal Oil Pressure – 28-51 psi at idle; 44-67 psi at 4000 RPM.

ENGINE OILING SYSTEM

A high output, gear type oil pump is mounted to engine block lower surface and is operated by camshaft.

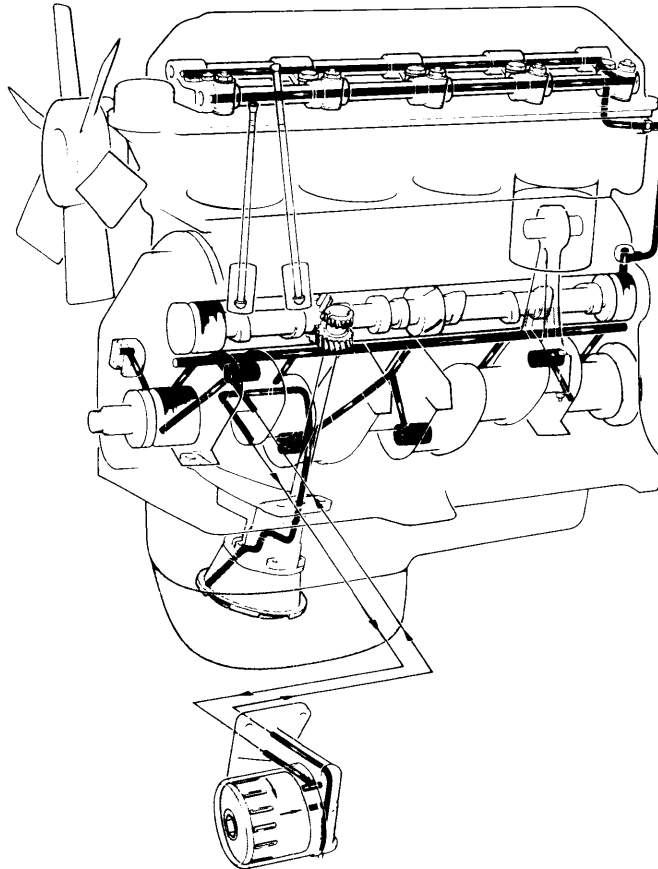

Fig. 13 Sectional View of Peugeot Engine Oiling Circuit with Detail of Components Lubricated

ENGINE COOLING

Thermostat – Opens at 165°F (73.9°C).

Cooling System Capacity – Approximately 8.25 qts.

WATER PUMP

1) Remove radiator, top hose, and fan belt. Disconnect heater hose from pump and the self-disengaging fan brush holder. Remove water pump.

2) To install, reverse removal procedures noting the following: clean contact surfaces before installing new gasket.

SELF-DISENGAGING FAN

Driven by water pump shaft and controlled by a thermal contact-breaker. Fan engages at 170-180°F (76.7-82.2°C) and disengages at 150-160°F (65.6-71.1°C).

TIGHTENING SPECIFICATIONS

Application	Ft. Lbs. (mkg)
Cylinder Head	See Text
Crankshaft Main Bearing Bolts	54 (7.5)
Connecting Rod Nuts	29 (4.0)
Camshaft Retaining Plate Bolts	12 (1.7)
Camshaft Sprocket Bolts	16 (2.25)
Crankshaft Pulley Bolt	123 (17)
Oil Pan Bolts	7 (1.0)
Flywheel-to-Crankshaft Bolts	49 (6.75)
Engine-to-Clutch Housing	16 (2.25)
Oil Pump Mounting Bolts	7 (1.0)

NOTE – Piston-to-liner clearance should be .002-.003" (.051-.076 mm).

NOTE – Piston pin is a press fit in piston.