

LUV PICKUP 4 CYLINDER

GENERAL SPECIFICATIONS										
Year	Displ.		Carburetor	HP at RPM	Torque (Ft. Lbs. at RPM)	Compr. Ratio	Bore		Stroke	
	cu. ins.	cc					in.	mm	in.	mm
1976	110.8	1816	1x2-Bbl.	80 @4800	95 @3000	8.5:1	3.31	84	3.23	82

ENGINE IDENTIFICATION

Engine number is located in casting on right upper center portion of cylinder head.

ENGINE REMOVAL

1) Disconnect battery cables, drain crankcase and cooling system. Disconnect carburetor linkage, all necessary water and fuel hoses, vacuum lines, and electrical leads. Also disconnect exhaust pipe at manifold flange. Remove radiator.

2) Disconnect drive shaft, clutch slave cylinder and speedometer cable. Remove gearshift lever assembly and exhaust pipe bracket. Attach suitable hoist and take up weight of engine. Remove front and rear engine mounts. Carefully pull engine forward adjusting hoist to clear stationary components.

INTAKE & EXHAUST MANIFOLD REMOVAL

1) Remove air cleaner and carburetor. Disconnect PCV valve, power brake vacuum line and exhaust pipe from exhaust manifold. Note for reinstallation position of lifting hanger.

2) Remove nuts, lock washers and flat washers holding manifolds to cylinder head. Slide manifolds off together. Once off, manifolds can be separated by removing exhaust manifold mounting studs. To install, reverse removal procedure.

NOTE — Torque manifold stud in sequence, working from inner nuts outward.

CYLINDER HEAD REMOVAL

1) Drain cooling system. Disconnect exhaust pipe from manifold. Disconnect all necessary water hoses, vacuum lines, carburetor linkage, and electrical leads. Remove air cleaner assembly and valve cover. Rotate number four cylinder into firing position. Lock timing chain adjuster by depressing and turning automatic adjuster slide pin 90° clockwise (See Fig. 6).

NOTE — Do not remove the timing chain from camshaft sprocket.

2) Remove timing chain sprocket from camshaft. Remove front cover. Using suitable tool (J-24239), remove cylinder head bolts in progressional sequence starting with outer bolts. Remove cylinder head, intake and exhaust manifolds as an assembly. To install, reverse removal procedure.

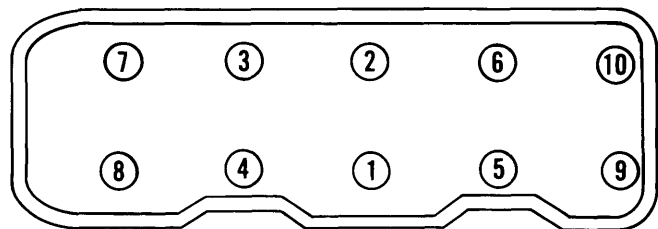

Fig. 1 Cylinder Head Tightening Sequence

VALVES							
Engine & Valve	Head Diam. In. (mm)	Face Angle	Seat Angle	Seat Width In. (mm)	Stem Diameter In. (mm)	Stem Clearance In. (mm)	Valve Lift In. (mm)
1816 cc Int.	1.67 (42.4)	45°	45°	.047-.063 (1.19-1.60)0009-.0022 (.023-.056)
Exh.	1.34 (34.0)	45°	45°	.047-.063 (1.19-1.60)0015-.0031 (.038-.079)

VALVE ARRANGEMENT

E-I-I-E-E-I-I-E

VALVE GUIDE

Removal & Installation — 1) Inspect inside diameter of valve guide for grooves or uneven wear. Measure inside diameter of valve guides with caliper gauge. Measure diameter of valve stem and compare measured values to determine clearance. If clearance is greater than .008" (.20

mm) for intake, or .010" (.25 mm) for exhaust, replace both valve and valve guide.

2) Drive valve guides toward upper face of cylinder head, using suitable valve guide replacer tool (J-26512). Valve guides cannot be driven downward. Valve guides are held in position by snap rings.

NOTE — Before installation of valve guide, remove lower spring seat.

LUV Engines

LUV PICKUP 4 CYLINDER (Cont.)

3) To install, apply engine oil to outer circumference of valve guide, and install into position in cylinder head. Holding valve guide installer tool (J-26512-1) and (J-26512-2) against valve guide, drive valve guide into cylinder head until tool bottoms on cylinder head.

NOTE — Replace valve whenever valve guide is replaced.

VALVE STEM OIL SEALS

Inspect intake and exhaust valve stem oil seal lips and inner face. Replace valve stem oil seals at time of reassembly, if wear is noticeable.

VALVE SPRINGS			
Engine	Free Length In. (mm)	PRESSURE Lbs. @ In. (kg @ mm)	
		Valve Closed	Valve Open
1816 cc Inner	1.78 (45.2)	21.5 @ 1.52 (9.7 @ 38.6)
	Outer	1.85 (47.0)	37.0 @ 1.61 (16.8 @ 40.9)

VALVE SPRING REMOVAL

Remove rocker arm shaft and bracket assembly. Remove spark plug, and connect compressed air to cylinder at spark plug opening. Using spring compressor tool (J-26513), compress valve spring and remove retainers, spring, and spring cap. Remove valve stem oil seal and lower spring seat. To install, reverse removal procedure.

VALVE SPRING INSTALLED HEIGHT

Visually check valve springs for damage and replace as necessary. Measure free length of valve springs using suitable calipers and replace if measured value is beyond limit. With a valve spring tester check valve spring tension and compare it with values in chart, replace as necessary.

NOTE — Install springs with close wound coils next to cylinder head.

ROCKER ARM ASSEMBLY

1) Loosen rocker shaft bracket nuts in sequence, starting with outer brackets. Remove the spring from the shaft, and then remove rocker arm brackets and arms keeping parts in order for reassembly.

2) Inspect rocker arm shaft for wear damage or excessive runout. If runout is greater than .0156" (.396 mm), replace shaft. Diameter of shaft is .8071" (20.5 mm). Replace shaft if diameter is less than .8012" (20.35 mm).

3) To install, apply engine oil to rocker arm shaft, rocker arms, and valve stems. Install longer shaft on exhaust side and shorter shaft on intake side. Aligning marks on shafts are turned to front side.

4) Assemble brackets and arms to shafts, so cylinder number (on upper face of bracket) is pointed to front of engine. Align No. 1 shaft bracket with mark on the intake and exhaust valve side rocker arm shafts. Place springs between shaft bracket and rocker arm. Punch mark on rocker arm shafts must be turned upward. Tighten shaft bracket nuts.

NOTE — Hold rocker arm springs with a wrench while torquing nuts, to prevent damage to spring. Torque nuts in sequence, starting with center bracket and working outward.

VALVE CLEARANCE

With No. 1 or No. 4 cylinder piston at top dead center, loosen lock nut and adjust intake valves to .006" (.15 mm), and exhaust valves to .010" (.25 mm). When valves are correctly adjusted reset lock nut.

Application	Valve Adjustment Sequence	
	Intake/Cylinder	Exhaust/Cylinder
No. 1 @ TDC.....	1,2.....	1,3
No. 4 @ TDC.....	3,4.....	2,4

PISTONS, PINS, RINGS						
Engine	PISTONS	PINS		RINGS		
	Clearance In. (mm)	Piston Fit In. (mm)	Rod Fit In. (mm)	Rings	End Gap In. (mm)	Side Clearance In. (mm)
1816 cc	.0018-.0026 (.046-.066)	ⓐ	.0024 (.061)	1	.008-.016 (.20-.41)
				2	.008-.016 (.20-.41)
				Oil	.008-.035 (.20-.89)

ⓐ — Press fit.

LUV PICKUP 4 CYLINDER (Cont.)

OIL PAN REMOVAL

Raise vehicle. Drain crankcase and remove front splash shield. Remove crossmember. Disconnect relay rod at idler arm and lower relay rod. Remove left hand bell housing brace. Remove oil pan bolts and pan. To install, reverse removal procedure.

PISTON & ROD ASSEMBLY

- 1) Position cylinder body so flywheel side is down. Using suitable tool, scrape carbon from upper part of cylinder wall.
- 2) Remove connecting rod bearing cap nuts and bearing cap. Using a wood rod, push piston, together with connecting rod, upward. Removal sequence is 1, 4, 2, & 3. **NOTE** — Ensure piston and connecting rod are pulled parallel to cylinder wall.
- 3) To install piston and rod assembly, position piston so notch mark on crown of piston is facing front of engine. Align cylinder number marks on connecting rods so they will be on right-hand side of front mark on piston.

PISTON PIN

Removal — Using a press and piston pin removal tool set (J-25270), press piston pin out of piston and connecting rod assembly.

NOTE — Manufacturer recommends replacing with NEW piston pins.

Installation — Install new pin by placing pilot through piston and connecting rod. Lightly oil piston pin and place piston, rod, pin, and ram on press base. Press in pin until its centered in connecting rod.

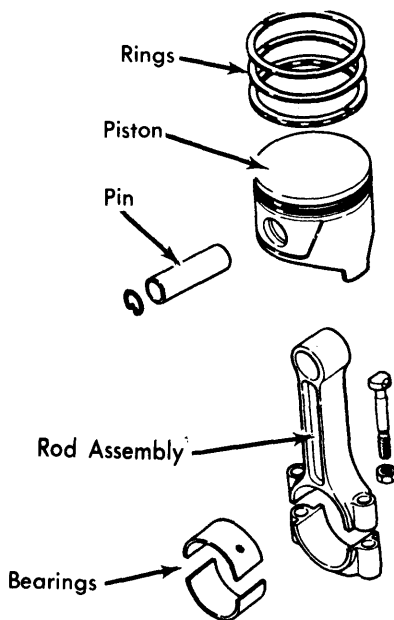

Fig. 2 Exploded View of Piston & Connecting Rod

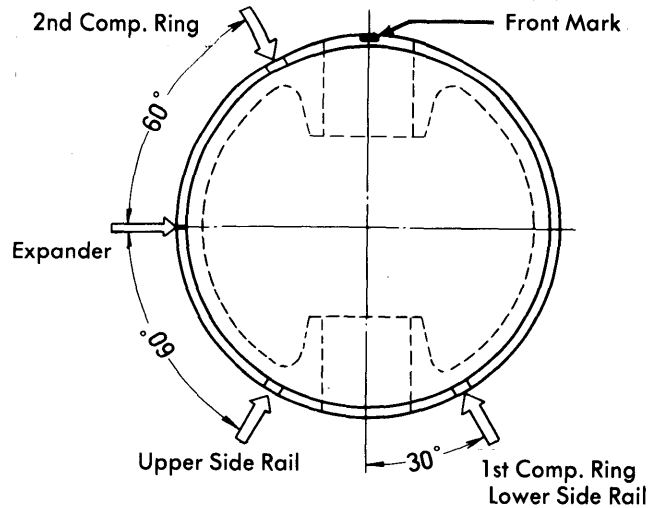

Fig. 3 Position of Piston Rings

PISTON RINGS

- 1) Assemble piston rings to piston with a piston ring expander. When replacing piston rings, position compression rings so that "NPR" or "TOP" mark is turned up. The expander ring and side rail is not marked.
- 2) Install oil control ring in this order; expander ring, lower side rail, and upper side rail. After installing all rings, apply clean engine oil to the entire rings. Check that rings turn smoothly in their ring grooves.

FITTING PISTONS

- 1) Check piston clearance by inserting piston pull-scale with .0018-.0026" feeler gauge, one inch long, into cylinder. Fit piston, crown first, into cylinder so feeler gauge is wedged by piston.
- 2) Holding piston to prevent side thrust, withdraw gauge with a steady pull on scale. Clearance is correct when gauge reads 1.1-2.2 lbs. **NOTE** — It is advisable to take several readings.
- 3) Measure weight of assembled pistons and compare the values. Ensure values between pistons are within .2 ozs. If value is exceeded, make necessary adjustments by selecting a connecting rod of suitable weight or by grinding.

Piston Size	Piston Class	
	Piston Grade	Piston Diameter In. (mm)
Standard.....	A.....	3.3049-3.3053 (83.944-83.955)
Standard.....	B.....	3.3053-3.3057 (83.955-83.965)
Standard.....	C.....	3.3057-3.3061 (83.965-83.975)
Standard.....	D.....	3.3061-3.3065 (83.975-83.985)

NOTE — Pistons are available in .020" and .040".

LUV Engines

LUV PICKUP 4 CYLINDER (Cont.)

CRANKSHAFT MAIN & CONNECTING ROD BEARINGS							
Engine	MAIN BEARINGS			CONNECTING ROD BEARINGS			
	Journal Diam.	Clearance	Thrust Bearing	Crankshaft End Play	Journal Diam.	Clearance	Side Play
1816	2.205 (56.01)	.0016 (.041)	No. 3	.118 (.3)	1.929 (48.99)	.0020 (.051)	.011 (.28)

MAIN & CONNECTING ROD BEARING SERVICE

NOTE — The following procedure is with engine, cylinder head, timing cover, oil pan, and timing chain removed.

Connecting Rod Bearings — After ensuring rod caps are marked for cylinder identification, remove rod caps. Use Plastigage method to check for proper clearance. If not within specifications, new bearings must be installed. New bearings are available in standard, .010", and .020".

NOTE — Always replace bearings in pairs. Never use a new bearing in combination with a used bearing.

Main Bearings — 1) With all bearing caps (except one being checked) tight, check clearances using Plastigage method. If clearances are excessive, undersized bearings will have to be installed. Remove upper bearings by inserting tool into oil hole of crankshaft and rotating crankshaft clockwise to roll bearing from engine.

2) To check crankshaft out of round place crankshaft on two "V" shaped blocks at No. 1 and No. 5 journals. Hold dial indicator in contact with No. 3 journal and slowly turn crankshaft, recording highest point on journal. Replace crankshaft if bend exceeds .0038" (.097 mm). Standard assembly value is .0012" (.030 mm) or less.

3) To check crankshaft end play, place bearings and crankshaft in crankcase. Install thrust bearing on both sides of No. 3 crankshaft journal. Shift crankshaft endwise and measure clearance between thrust bearing and journal side face. If clearance is greater than .0117" (.297 mm), install oversize thrust bearings. Standard value is .0024-.0094" (.061-.239 mm).

NOTE — Main bearing caps are installed with marks on bottom of caps facing forward. Number two and three bearing caps can be distinguished by an "A" stamped on caps.

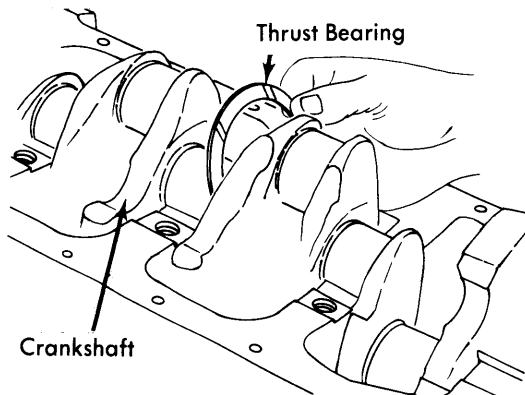

Fig. 4 Installing Thrust Bearing

REAR MAIN OIL SEAL

Removal — Remove oil pan and transmission. Remove clutch (if equipped). Remove starter and flywheel assembly. Remove seal retainer bolts and pry seal out of retainer.

Installation — To install, reverse removal procedure noting the following: Fill clearance between lips of seal with grease, and coat lips of seal with engine oil. Place retainer on flat surface and drive seal into place using suitable seal installer tool (J-22354).

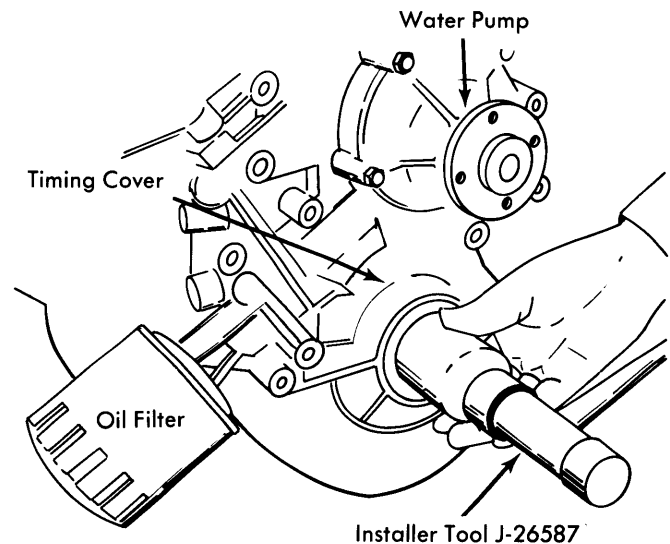

Fig. 5 Installing Timing Cover Oil Seal

FRONT COVER & OIL SEAL

Removal — Remove cylinder head and oil pan as previously outlined. Remove oil pump pickup tube. Remove harmonic balancer and AIR belt. If equipped with air conditioning, remove compressor and mounting brackets. Remove distributor cap (wires attached), then remove distributor. Remove front cover.

Installation — Align oil pump drive gear punch mark with oil filter side of cover. Align center of dowel pin with alignment mark on oil pump case. Rotate No. 1 and 4 cylinders to top dead center. Install front cover by engaging pinion gear with oil pump drive gear on crankshaft (See Fig. 5). Install front cover and reverse removal procedure.

LUV PICKUP 4 CYLINDER (Cont.)

CAMSHAFT			
Engine	Journal Diam. In. (mm)	Clearance In. (mm)	Lobe Lift In. (mm)
1816 cc	1.3362-1.3370 (33.94-33.96)	.0024 ① (.061)

① — End play is .002-.006" (.05-.15 mm).

CAMSHAFT REMOVAL & INSPECTION

1) Remove valve cover. Position No. 4 cylinder in firing position. Remove distributor cap and mark rotor position. Lock timing chain adjuster by depressing and turning automatic adjuster slide pin 90° in a clockwise direction (See Fig. 6).

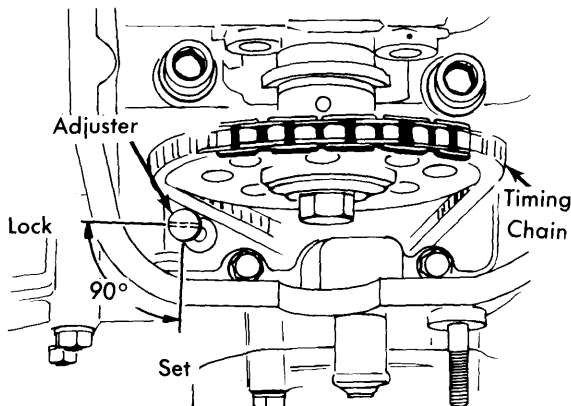

Fig. 6 Locking Timing Chain Adjuster

NOTE — After locking chain adjuster, check that chain is in free state.

2) Remove timing sprocket from camshaft, keeping sprocket on chain damper and tensioner without removing sprocket from chain. Remove rocker arm shaft and bracket assembly. Remove camshaft.

3) Check camshaft journals and cams for wear or damage. Measure height of cams with a micrometer, and replace camshaft if height is less than 1.4311" (36.3 mm). If working faces of cams have slight scores or steps, eliminate them by honing. Measure outside diameter of camshaft journals, replace camshaft if diameter is less than 1.3307" (33.8 mm). To install, reverse removal procedure.

CAMSHAFT END PLAY

Measure camshaft end play with thrust plate installed in thrust groove. Replace thrust plate if end play is found to exceed .0078" (.198 mm). Standard end play is .002-.006" (.05-.15 mm).

CAMSHAFT BEARING REPLACEMENT

Camshaft bearings are not replaceable. Camshaft rides in a carrier. If clearance is beyond limits, replace camshaft carrier.

VALVE TIMING				
Engine	INTAKE		EXHAUST	
	Open (BTDC)	Close (ALDC)	Open (BLDC)	Close (ATDC)
1816 cc	21°	65°	55°	20°

TIMING CHAIN REPLACEMENT

1) Remove timing chain as outlined previously. Remove camshaft sprocket and timing chain. All other parts can now be inspected for wear, replace as necessary. If crankshaft sprocket needs replacement, remove with suitable gear puller (J-25031).

2) Install timing sprocket and pinion gear, groove side toward front cover. Align key grooves with key on crankshaft, then drive into position with suitable installing tool (J-26587). Turn crankshaft so that key is turned toward cylinder head side and No. 1 and 4 cylinders are at top dead center.

NOTE — Keep timing chain engaged with camshaft sprocket until sprocket is installed on camshaft.

3) Align mark plate on timing chain with mark on crankshaft timing sprocket. Side of chain with mark plate is on front side, and side of chain with most links between mark plates is on chain guide side. Camshaft timing sprocket marked side, faces forward and marks align with timing chain mark plate. Install front cover.

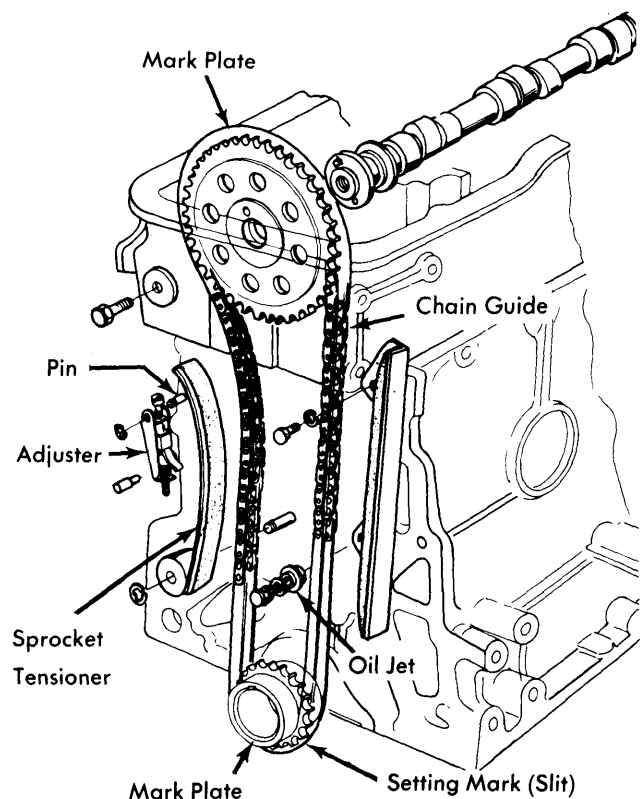

Fig. 7 Camshaft, Timing Chain & Components

LUV PICKUP 4 CYLINDER (Cont.)

ENGINE OILING

ENGINE OILING SYSTEM

Trochoid type oil pump is designed to deliver 3.7 gallons of oil per minute through the engine at a pump speed of 1400 RPM. Lubricating system is designed to deliver oil at a rate of 57 psi.

Crankcase Capacity – 4.7 quarts.

Oil Filter – Full-flow disposable canister type.

Normal Oil Pressure – 57 psi.

Relief Valve – Located on side of cylinder block near oil filter. Opening pressure of relief valve is 57-71 psi.

OIL PUMP

NOTE – Oil pump can be serviced with engine in or out of vehicle. Procedure given is with engine in vehicle.

Removal – Remove front cover, distributor, and oil pan as outlined previously. Remove oil pickup tube. Remove oil pump mounting bolts and remove pump assembly.

Inspection – 1) Measure tip clearance with a feeler gauge, between drive rotor and driven rotor. Replace entire pump assembly if clearance is greater than .0079" (.2 mm).

2) Measure clearance between driven rotor and inner wall of pump body. Replace entire pump assembly if clearance is greater than .0098" (.249 mm).

3) Using a square and a feeler gauge, measure clearance between drive rotor, driven rotor, and oil pump cover. Replace entire pump assembly if clearance is greater than .0079" (.2 mm). Inspect all parts wear or damage.

Installation – 1) Align mark on camshaft with mark on No. 1 rocker arm shaft bracket. Align notch on crankshaft pulley with "O" mark on front cover. When the two sets of marks are aligned, No. 4 cylinder is at top dead center on compression stroke.

2) Install driven rotor so that alignment mark aligns with mark on the drive rotor. Engage drive gear with pinion gear on crankshaft so alignment mark is turned rearward and is away from crankshaft by approximately 20° in clockwise rotation (See Fig. 9).

3) When oil pump is installed; make sure mark on drive gear is turned to rear side as viewed from the clearance between front cover and cylinder block. Slit at end of shaft must be parallel with front face of cylinder block, and is offset as viewed through distributor fitting hole.

4) Install pump cover by fitting it to the dowel pins, then install mounting bolts. Install relief valve assembly and rubber hose on cover. Reverse removal procedure.

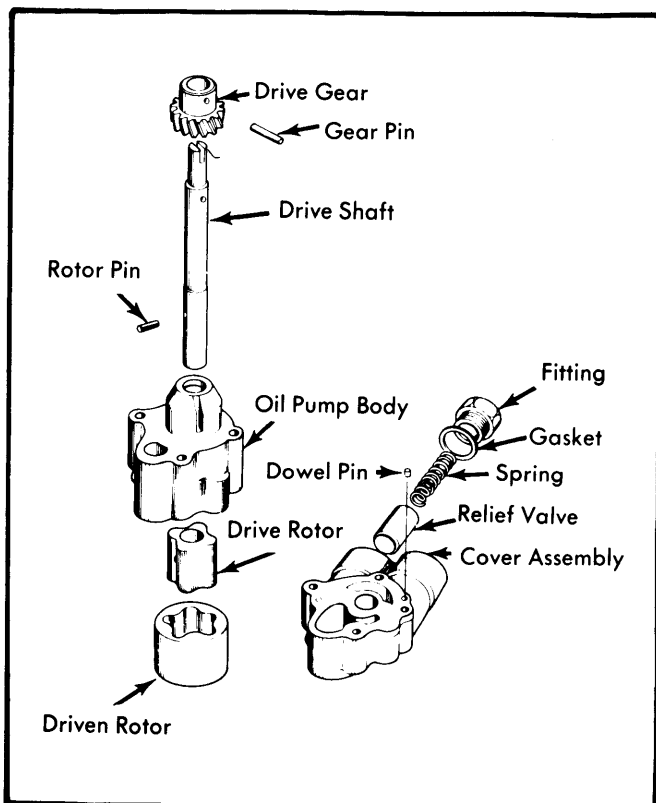

Fig. 8 Exploded View of Oil Pump Assembly

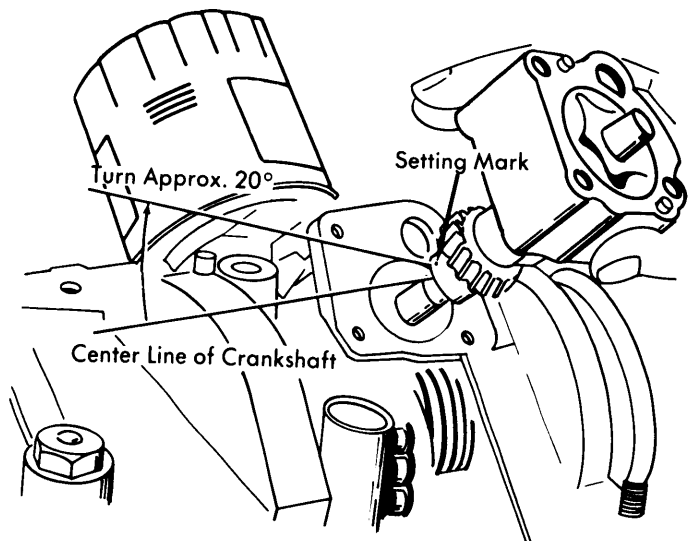

Fig. 9 Installing Oil Pump

LUV PICKUP 4 CYLINDER (Cont.)

ENGINE COOLING

WATER PUMP

Disconnect negative battery cable. Remove lower cover. Drain cooling system. If equipped with air conditioning, remove fan and air pump drive belt. Remove fan, fan pulley, and air pump drive pulley. Remove set plate and pulley. On all other models remove fan nuts and fan. On all models, remove attaching bolts and water pump from vehicle.

Thermostat — Thermostat begins to open at 175-180°F (79.4-82.2°C) and is fully open at approximately 200°F (93.3°C).

Cooling System Capacity — 1.6 gallons.

TIGHTENING SPECIFICATIONS

Application	Ft. Lbs. (mkg)
Cylinder Head	
Step 1	61 (8.43)
Step 2	72 (9.95)
Main Bearings	72 (9.95)
Connecting Rod Bearings.....	33 (9.54)
Flywheel	69 (9.54)
Camshaft Sprocket	58 (8.02)
Rocker Arm Shaft Bracket Nuts	16 (2.21)